



Installation Manual

Energy Storage System (ESS)

Storion-SMILE-T10 (Indoor)



V01

IMPRINT

Germany

Alpha ESS Europe GmbH

Tel.: +49 (0)6103 459 160-1

E-mail: europe@alpha-ess.de

Web: www.alpha-ess.de

Add: Paul-Ehrlich-Straße 1a

63225 Langen

China

Alpha ESS Co., Ltd.

Tel.: +86 (0)513 806 868 91

E-mail: info@alpha-ess.com

Web: www.alpha-ess.com

Add: JiuHua Road 888, High-Tech Industrial Development Zone

226300 Nantong City, Jiangsu Province

Australia

Alpha ESS Australia Pty. Ltd.

Tel.: +61 1300 968 933

E-mail: australia@alpha-ess.com

Web: www.alpha-ess.com.au

Add: Suite 1, Level 1, 530 Botany Road, Alexandria, NSW, 2015

Italy

Alpha ESS Italy S.r.l.

Tel.: +39 (0)599 239 50

E-mail: info@alpha-ess.it

Web: <https://it.alpha-ess.com/>

Add: Via Loda,17-41013 Castelfranco Emilia(MO)

Dec. 16th, 2018

Copyright Statement

This manual is under the copyright of Alpha ESS Co., Ltd. with all rights reserved. Please keep the manual properly and operate in strict accordance with all safety and operating instructions in this manual. Please do not operate the system before reading through the manual.

Version Information

Version	Date	Content
V01	15032019	New

Content

IMPRINT	I
Copyright Statement	II
Version Information	II
Content	III
1. Introduction	5
1.1 System Introduction	5
1.2 General Precautions	6
1.3 Parts List	8
1.4 System Appearance	10
1.4.1 Battery	11
1.4.2 HV50056.....	12
1.4.3 Inverter Cable Box.....	13
1.5 Liability Limitation	13
2. Installation	14
2.1 Installation Site and Environment	14
2.1.1 General.....	14
2.1.2 Restricted Locations.....	15
2.2 Installation	16
2.3 Wiring	22
2.4 Power Meter	29
2.4.1 Meter ADL-3000 (If Applicable)	30
2.4.2 ACR10R Meter (If Applicable).....	34
2.4.3 Meter setting.....	35
3. System Operation	37
3.1 Switch on	37
3.2 Switch off	37
4. EMS Introduction and Set up	38
4.1 Function Description	38
4.2 Setting	39
4.3 EMS Communication Checking	42
4.4 Assembling of the Front Panels	43

5. Online Monitoring.....	43
6. Annex.....	46
6.1 Datasheet – AlphaESS Storion-SMILE-T10	46

1. Introduction

1.1 System Introduction

AlphaESS Storion-SMILE-T10 (incl. M4856-S, HV50056 and SMILE-T10-INV) can be applied in DC-coupled systems (mostly new installation), AC-coupled systems (mostly retrofit) and Hybrid-coupled systems (mostly retrofit, and PV capacity-increase), as the following scheme:

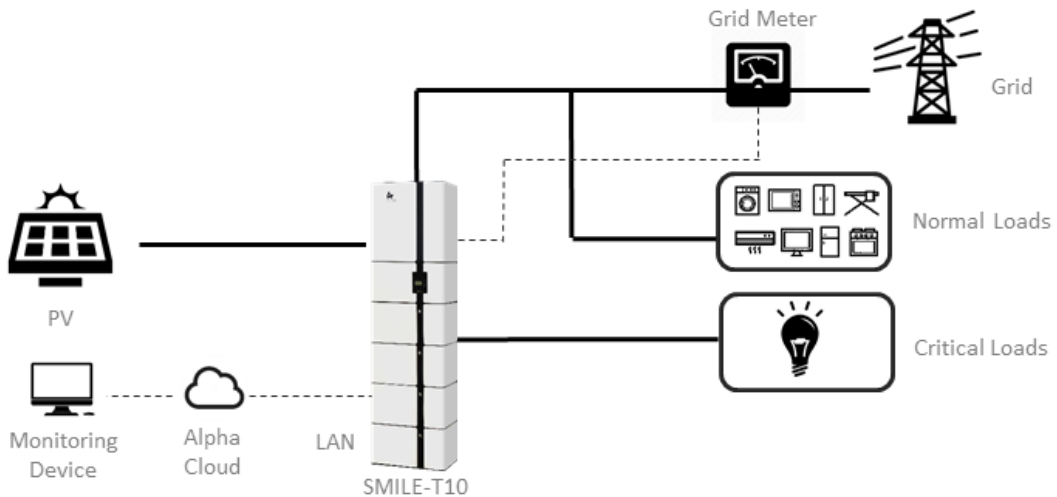

Figure 1 DC-coupled Storage System – Scheme

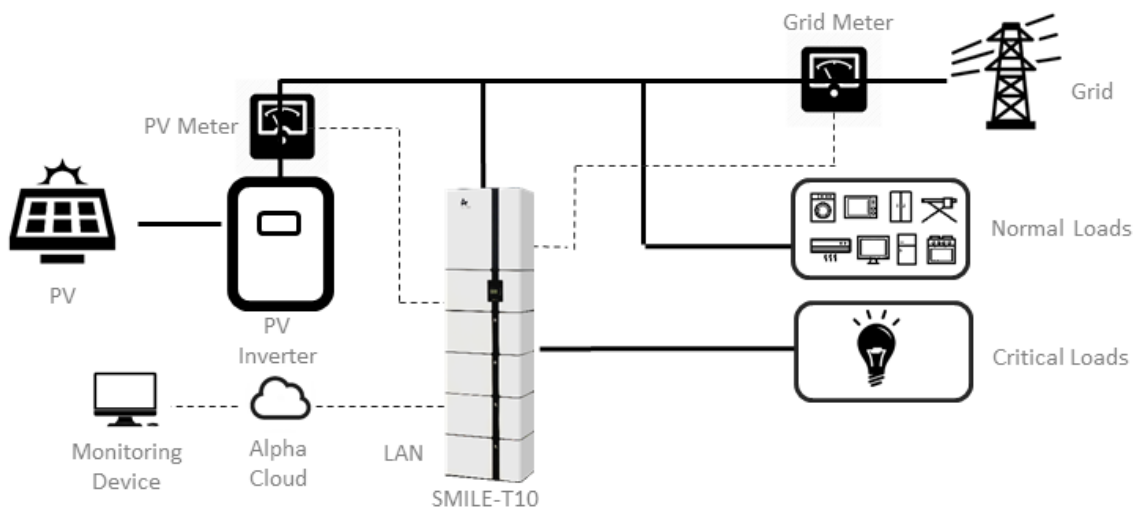

Figure 2 AC-coupled Storage System – Scheme

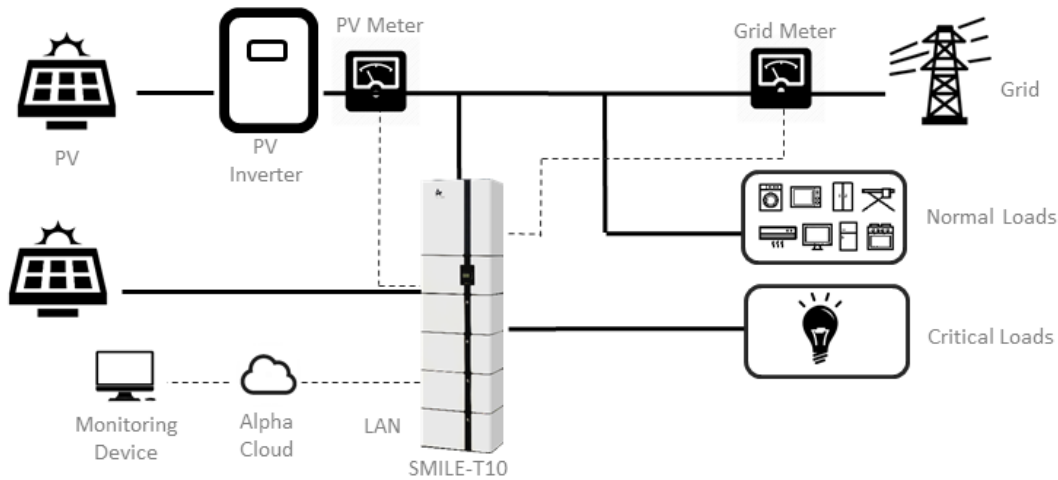

Figure 3 Hybrid-coupled Storage System – Scheme

CAUTION:

For the AC-/ Hybrid-coupled system, unlike DC, two power meters are to be mounted.

1.2 General Precautions

DANGER

Danger to life due to high voltages of the PV array, battery and electric shock.

When exposed to sunlight, the PV array generates dangerous DC voltage which will be present in the DC conductors and the live components of the inverter. Touching the DC conductors or the live components can lead to lethal electric shocks. If you disconnect the DC connectors from the system under load, an electric arc may occur leading to electric shock and burns.

- Do not touch uninsulated cable ends.
- Do not touch the DC conductors.
- Do not open the inverter and battery.
- Do not wipe the system with damp cloth.
- Have the system installed and commissioned by qualified people with the appropriate skills only.
- Prior to performing any work on the inverter or the battery pack, disconnect the inverter from all voltage sources as described in this document.

WARNING

Risk of chemical burns from electrolyte or toxic gases.

During standard operation, no electrolyte shall leak from the battery pack and no toxic gases shall form. Despite careful construction, if the Battery Pack is damaged or a fault occurs, it is possible that electrolyte may be leaked or toxic gases formed.

- Do not install the system in any environment of temperature below -10°C or over 50°C and in which humidity is over 85%.
- Do not touch the system with wet hands.
- Do not put any heavy objects on top of the system.
- Do not damage the system with sharp objects.
- Do not install or operate the system in potentially explosive atmospheres or areas of high humidity.
- Do not mount the inverter and the battery pack in areas containing highly flammable materials or gases.
- If moisture has penetrated the system (e.g. due to a damaged enclosure), do not install or operate the system.
- Do not move the system when it is already connected with battery modules.
- Secure the system to prevent tipping with restraining straps in your vehicle.
- The transportation of AlphaESS Storion-SMILE-T10 must be made by the manufacturer or an instructed personal. These instructions shall be recorded and repeated.
- A certified ABC fire extinguisher with minimum capacity of 2kg must be carried along when transporting.
- It is totally prohibited to smoke in the vehicle as well as close to the vehicle when loading and unloading.
- For the exchange of a battery module, please request for new hazardous goods packaging if needed, pack it and let it be picked up by the suppliers.
- In case of contact with electrolyte, rinse the affected areas immediately with water and consult a doctor without delay.

**CAUTION:****Risk of injury through lifting or dropping the system.**











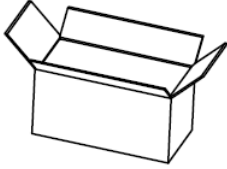

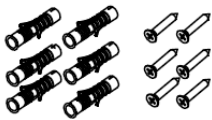
The inverter and battery are heavy. There is risk of injury if the inverter or battery is lifted incorrectly or dropped during transport or when attaching to or removing from the wall.

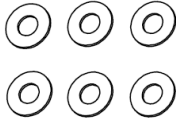

- Lifting and transporting the inverter and battery must be carried out by more than 1 person.

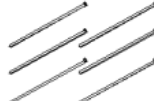

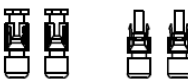
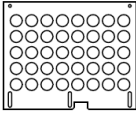
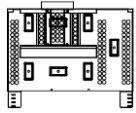

1.3 Parts List

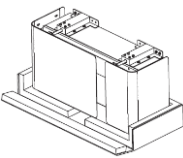
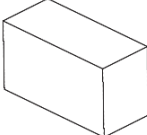
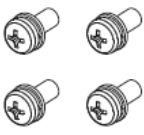



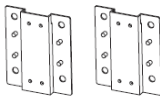

Check the following parts list to ensure it is complete.

AlphaESS delivers a total system separately on site to client, this consists of:

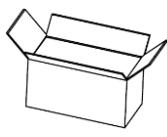
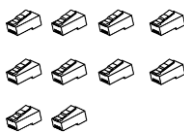
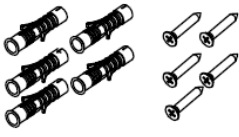
SMILE-T10_INV				
				
T10-INV box (X1)	Communication cable (X1)	Screw package: Expansion tube (X6) Expansion screw (X6)	DC power cables: Positive-Negative power line (X1)	Gasket (X6)
				
AC terminal (X12)	Cable bond (X1)	Hexagon nuts with flange (X2)	Cable tie (X30)	Communication cable (X1) BAT-BAT
				
DC connectors: Positive X2, negative X2	Bracket A (X1)	Bracket B (X1)	3-phase Meter (X1): ADL3000 or ACR10R	Installation Manual (X1)

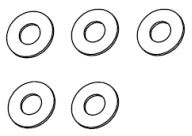
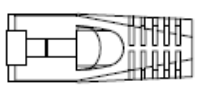
M4856-S				
				
Battery pack (X1)	PE Protective bag (X1)	Screw M5*10(X4)	Screw package: Expansion tube (X4) Expansion screw (X4)	Gasket (X4)

				
Bracket (X2)	Battery connector: Black power line (X1)	Battery communication line (X1)	Hexagon nuts with flange (X4)	Cable tie (X6)

HV50056				
				
HV50056 box (X1)	RJ45 Connectors (X12)	Screw package: Expansion tube (X5) Expansion screw (X5)	Battery power cables: Positive power cable (X1) Negative power cable (X1)	Gasket (X5)
				
Terminal resistance (X1)	Cable bond (X1)	Hexagon nuts with flange (X4)	User Manual (X1): M4856-S & HV50056	Quick Installation Manual (X1): M4856-S & HV50056

1.4 System Appearance

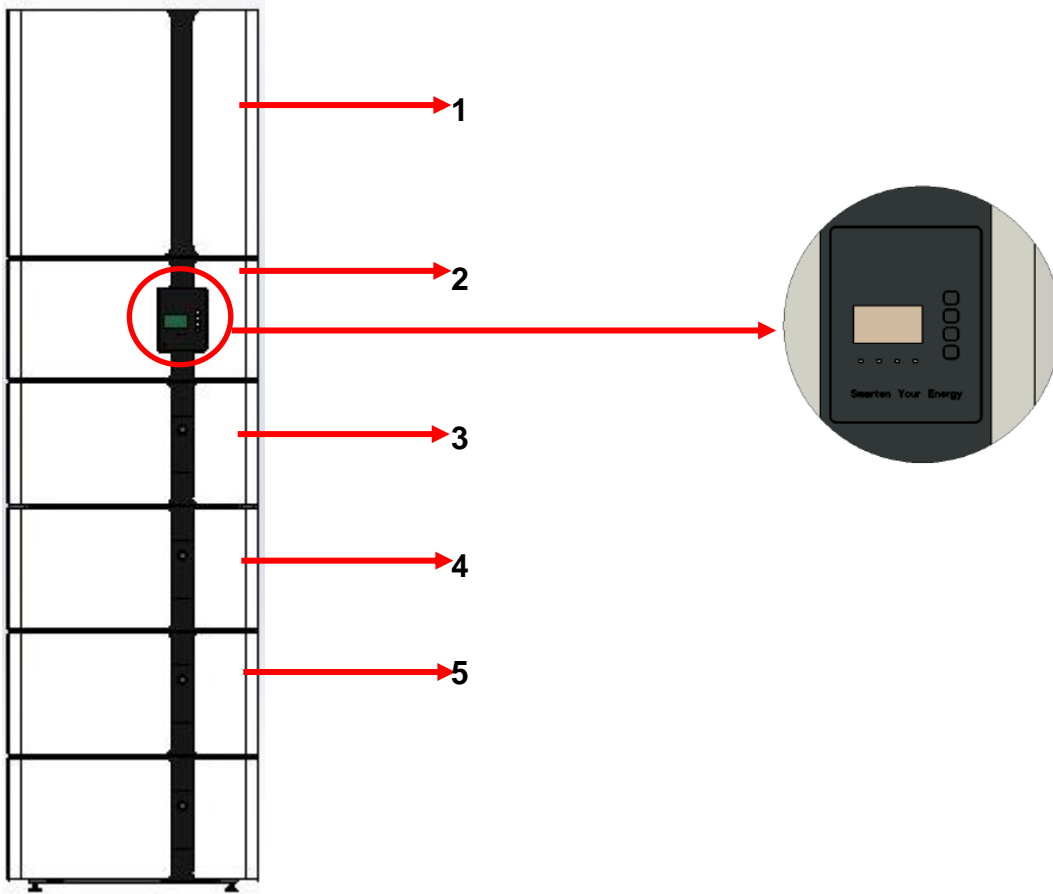

Figure 4 Storion-SMILE-T10 Delivery Scope

Object	Description
1	Hybrid Inverter with Cable Box
2	HV50056 (High-voltage Control Box)
3	M4856-S (BAT1)
4	M4856-S (BAT2)
5	M4856-S (BAT3)
6	M4856-S (BAT4)

1.4.1 Battery

1.4.1.1 Specifications

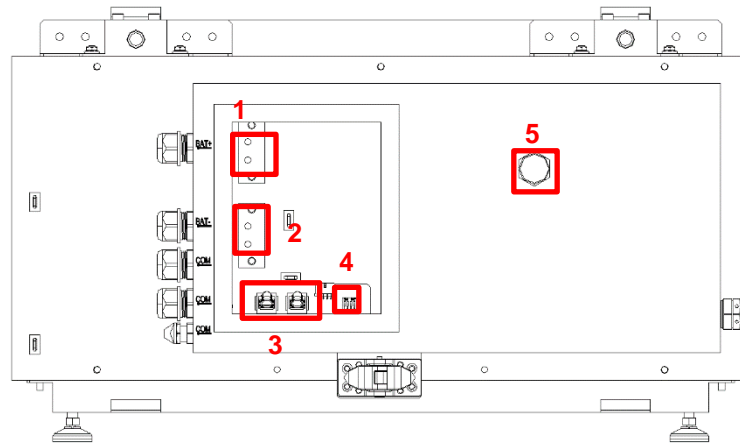

Figure 5 M4856 Interface Definition

No.	Description
1	Positive Pole
2	Negative Pole
3	2 x COM Port (CAN)
4	Dip Switch
5	LED

1.4.1.2 LED Display

In normal condition, LED display three status:

Status	Normal	Protection	Fault
LED Display	Green light blinks for 1sec	Red light blinks for 1sec	Red and green light blink for 1sec

1.4.2 HV50056

1.4.2.1 Specification

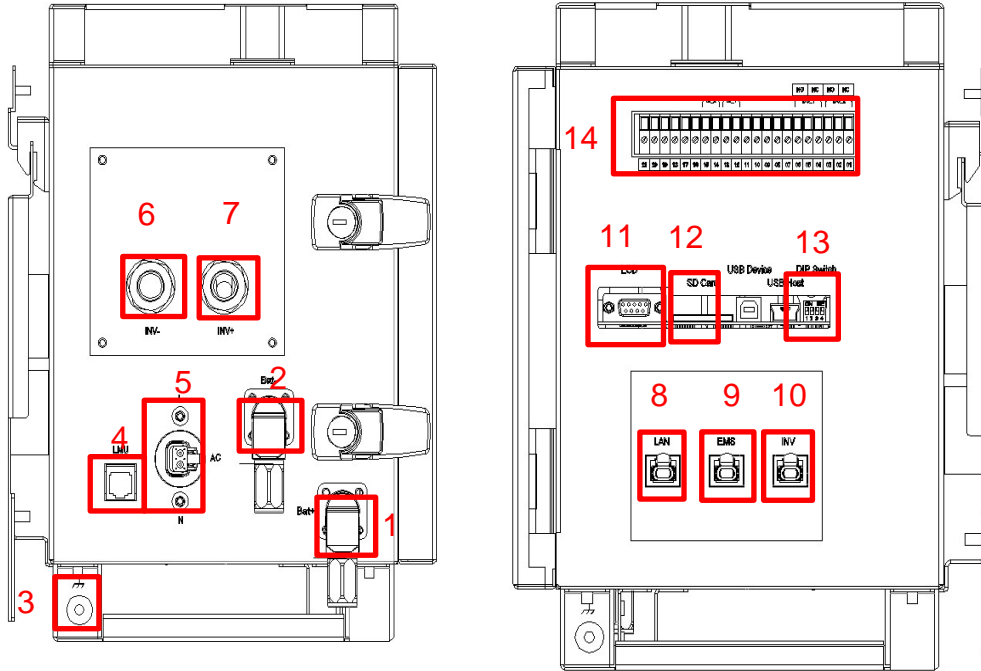

Figure 6 High-voltage Control Box – Left & Right View

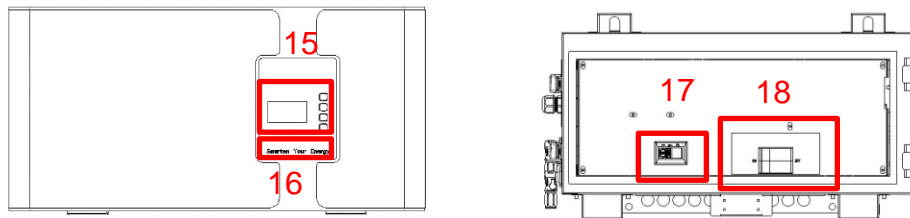

Figure 7 High-voltage Control Box – Front View, Inside –Front View

No.	Description	No.	Description
1	Bat+	10	INV COM Port
2	Bat-	11	External LCD Wiring Port
3	Earthing Point X 2 (Required To Connect With Grounding Copper)	12	SD Card
4	LMU COM Port (CAN)	13	Dip Switch
5	AC Auxiliary Input	14	Dry Contact
6	Inv-	15	LCD Screen
7	Inv+	16	LED Indicator
8	LAN COM Port	17	Molded Case Circuit Breaker (MCCB)
9	EMS Meter Communication Port	18	AC Switch (For AC Auxiliary Input)

1.4.3 Inverter Cable Box

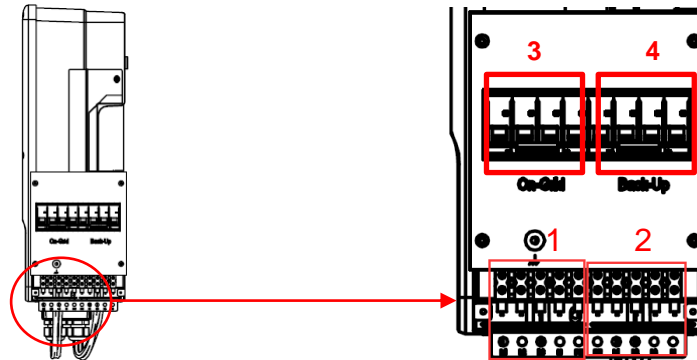

Figure 8 Inverter Cable Box

Item	Description
1	On-Grid Wiring Ports (L1, L2, L3, N, PE)
2	Back Up Wiring Ports (L1, L2, L3, N, PE)
3	On-Grid AC Breaker
4	Back Up AC Breaker

1.5 Liability Limitation

Any product damage or property loss caused by the following conditions AlphaESS does not assume any direct or indirect liability.

- Product modified, design changed or parts replaced without AlphaESS authorization;
- Changes, or attempted repairs and erasing of series number or seals by non AlphaESS technician;
- System design and installation are not in compliance with standards and regulations;
- Failure to comply with the local safety regulations (VDE for DE, SAA for AU);
- Transport damage (including painting scratch caused by rubbing inside packaging during shipping). A claim should be made directly to shipping or insurance company in this case as soon as the container/package is unloaded and such damage is identified;
- Failure to follow any/all of the user manual, the installation guide and the maintenance regulations;
- Improper use or misuse of the device;
- Insufficient ventilation of the device;
- The maintenance procedures relating to the product have not been followed to an acceptable standard;
- Force majeure (violent or stormy weather, lightning, overvoltage, fire etc.);
- Damages caused by any external factors.

2. Installation

This Manual introduces the basic steps how to install and set up AlphaESS Storion-SMILE-T10

M4856-S is a sealed component with no access to battery terminals or cell components within module.

 NOTE: please pay attention for unpacking the battery, the worst case is that some components could be damaged.

2.1 Installation Site and Environment

2.1.1 General

The M4856-S has two versions, one is indoor, and another is outdoor. This SMILE-T10 energy storage system (indoor version) can only be installed in an indoor location. This SMILE-T10 energy storage system (outdoor version) can be installed in an outdoor or an indoor location.

Where SMILE-T10 systems are installed within a room, shall be located so that access to SMILE-T10 is not obstructed by the structure of the building, fixtures and fittings within the room.

SMILE-T10 adopts natural ventilation. The location should be clean, dry and adequately ventilated. The room's entry doors and panels shall open in the direction of egress and allow unobstructed access to the SMILE-T10 for installation and maintenance purposes.

The following location are **not allowed** for installation:

- habitable rooms;
- in ceiling spaces;
- wall cavities;
- on roofs not specifically deemed suitable;
- areas of access/egress;
- under stairways;
- under access walkways;
- sites where the freezing point is reached, like garages, carports or other places;
- sites with humidity and condensation over 85%;
- sites which are salty and where humid air can penetrate;
- earthquake areas –additional security measures are required here;
- sites that are higher than 3000 meters above the sea level;
- sites with explosive atmosphere;
- sites with direct sunlight;
- sites with extreme change of ambient temperature;
- wet rooms;
- sites with highly flammable materials or gases; or

- sites with a potentially explosive atmosphere;

2.1.2 Restricted Locations

Where the SMILE-T10 is located on or within 300mm of the wall or structure separating it from the habitable room, the barrier shall extend —

- 1000 mm beyond the vertical sides of the SMILE-T10;
- 300 mm above the SMILE-T10; and
- to the extent of the bottom of the SMILE-T10.

Please refer to Figure 9.

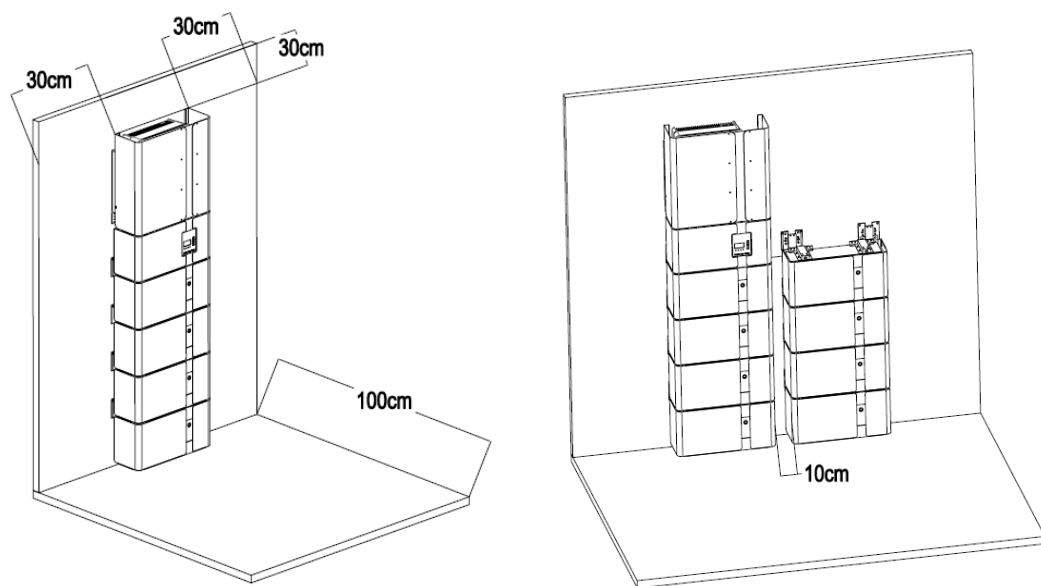

Figure 9 Distance limit of installation to Neighboring Objects

Where the top of the SMILE-T10 is within 300 mm of the ceiling or structure above the SMILE-T10, the ceiling or structure surface shall be suitably non-combustible for an area of 600 mm past the extremities of the SMILE-T10.

Where more than 4 batteries are installed, some batteries shall be installed beside, distance between two rows batteries shall be not less than 100 mm

SMILE-T10 shall be mounted with the highest point no greater than 2.2 m above the floor or platform.

2.2 Installation

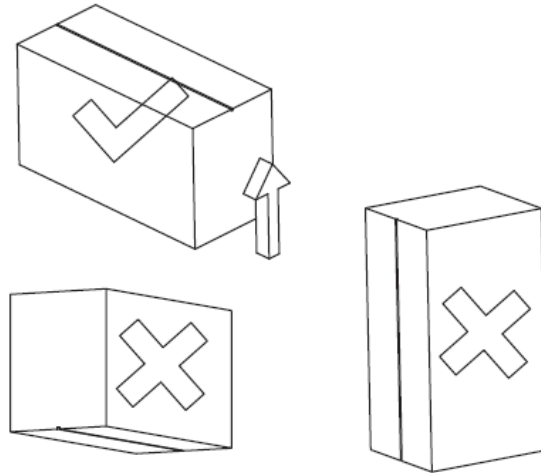

Figure 10 Unpacking the Battery

Step 1: Take out the battery from the packaging box.

i Note: the packaging box must be placed in accordance with the marking direction, the upward carton, the other direction of the unpacking is wrong.

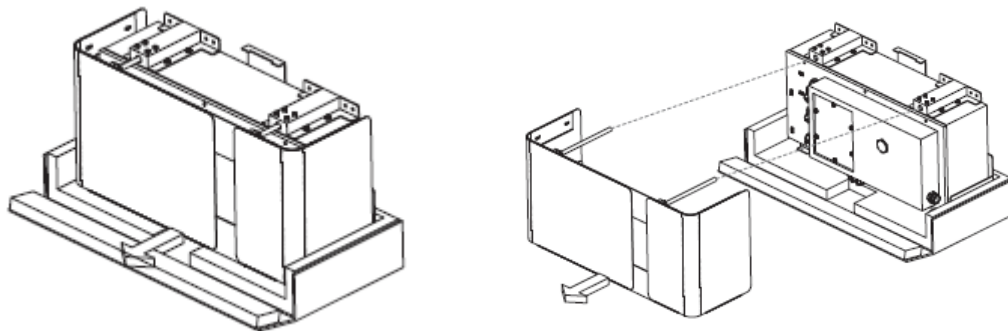

Figure 11 Removing Front Panel

Step 2: Pull the buckle from the bottom right in the middle and pull the top two guide rods to remove the front panel.

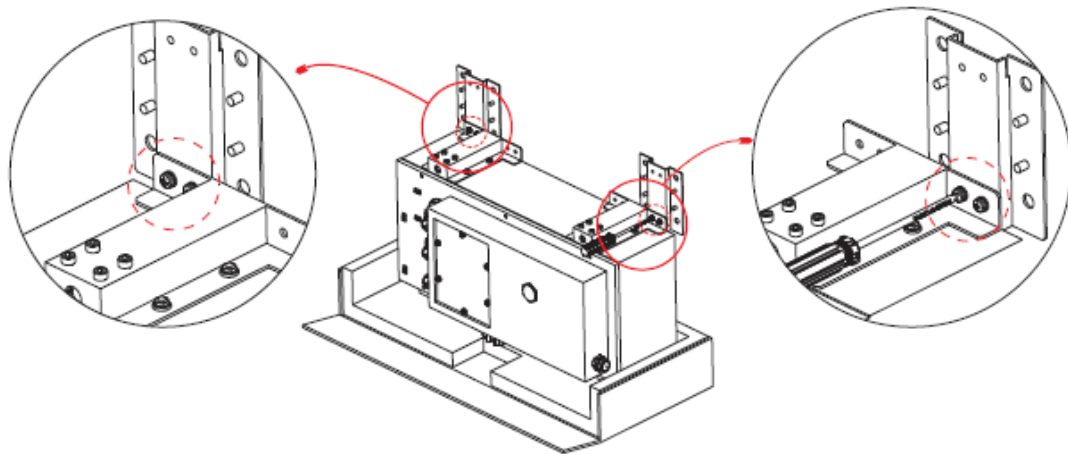

Figure 12 Assembling Battery Brackets

Step 3: Use a screwdriver to assemble the battery mounting bracket on the outside of the battery, as Figure 12 shows.

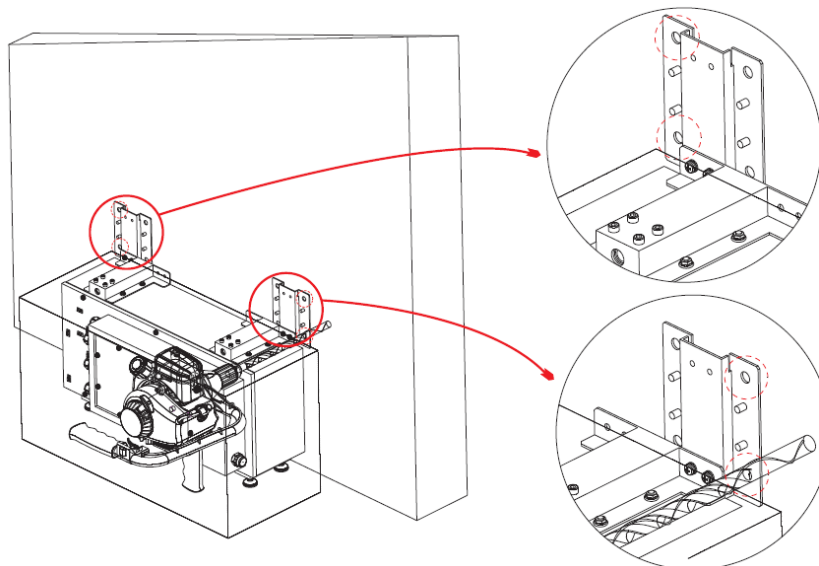

Figure 13 Placing Battery

Step 4: Confirm the installation place at first.

Push the battery against the wall and confirm the location of the battery with a horizontal ruler.

Pack the PE bag on the battery to block out the dust before drilling.

Please drill four holes (two on each side) directly on the wall at the marking positions of the brackets with an impact drill (bit ϕ 8.0mm, length 20cm), and the depth of each hole is about 7 cm.

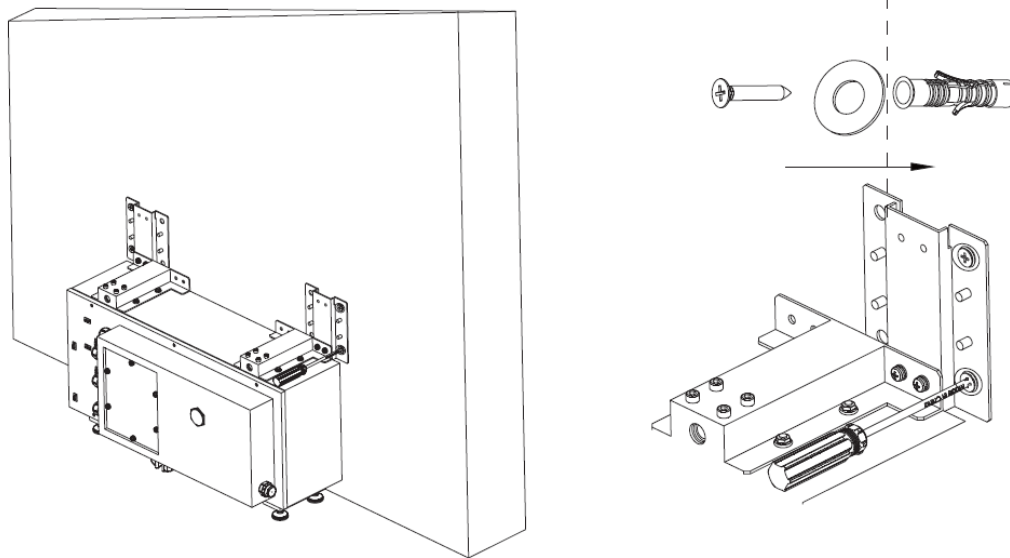

Figure 14 Mounting Battery

Step 5: Insert the expansion tube into the drilled hole. Pass the expansion screw through the gasket and lock with a screwdriver, as Figure 14 shows.

Step 6: M4856-S can be stackable with max. 4 batteries in each row. To install another battery repeat Steps 1~5.

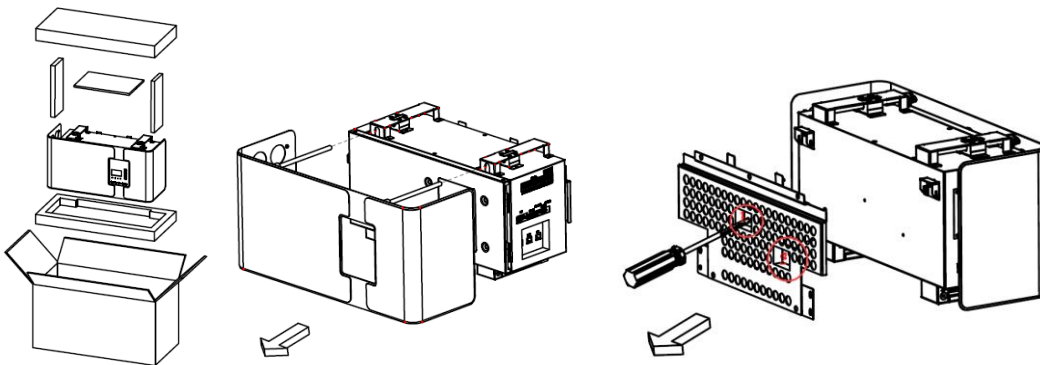

Figure 15 Unpacking the High-voltage Control Box

Step 7: Take the HV50056 out of the packaging box. Pull out the top two guide rods and remove the front panel. Remove the rear bracket from the HV50056, as shown in Figure 15.

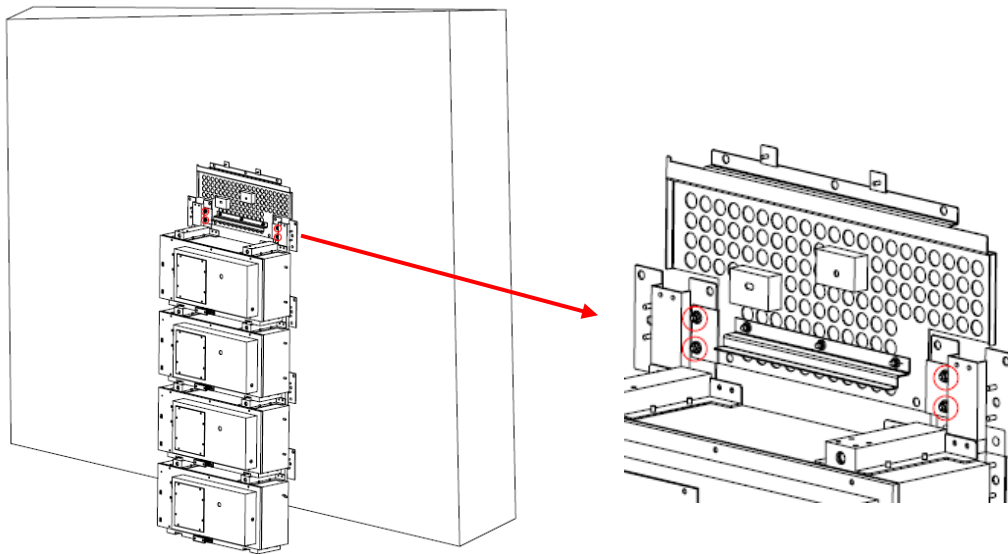

Figure 16 Placing the Rear Bracket of HV50056

Step 8: Fix the HV50056 rear bracket with flange nuts on the two bracket of the top battery, as shown in Figure 16.

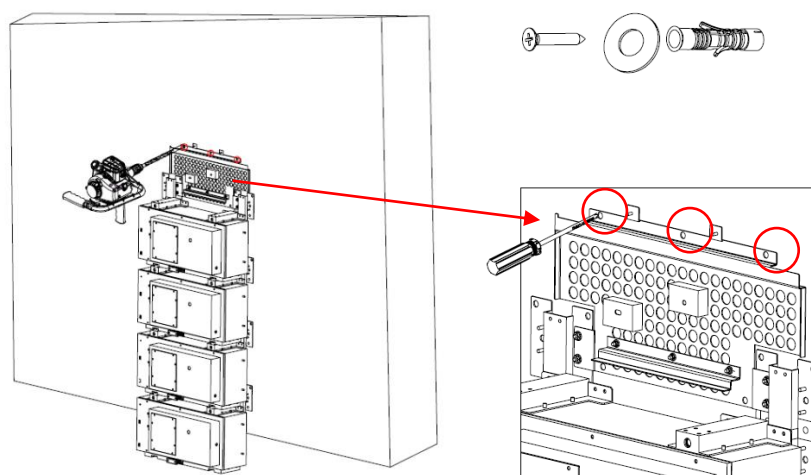

Figure 17 Installation of the Rear Bracket of HV50056

Step 9: Cover the PE bag on the top battery to block out the dust before drilling.

Please drill holes directly on the wall at the marking positions of the brackets with an impact drill (bit ϕ 8.0mm, length 20cm), and the depth each hole is about 7 cm.

Please insert the expansion tube into the drilled hole. Pass the tapping screw through the gasket and lock with a screwdriver, as Figure 17 shows.

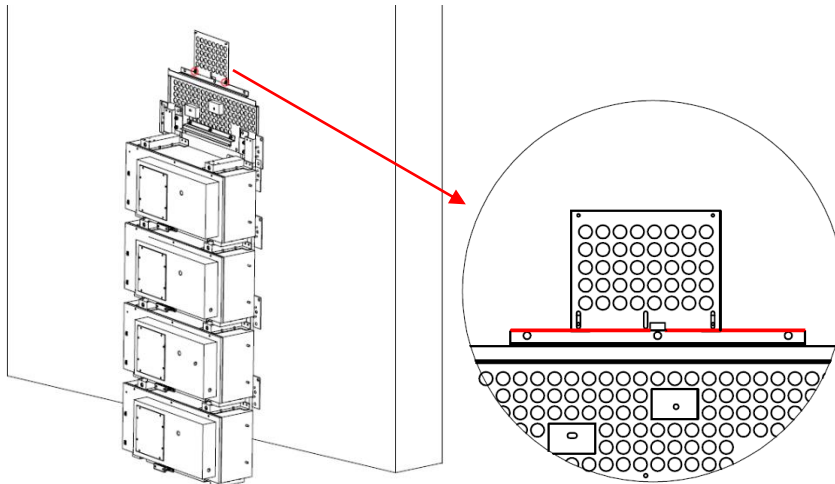

Figure 18 Installation of the Bracket A of the Inverter

Step 10: Please remove the nuts from the rear bracket of HV50056 and fix the bracket A of the inverter on the rear bracket of HV50056 with the flange nuts, as shown in Figure 18.

i The bottom of the bracket A shall be placed at the same horizontal line with the rear bracket of HV50056.

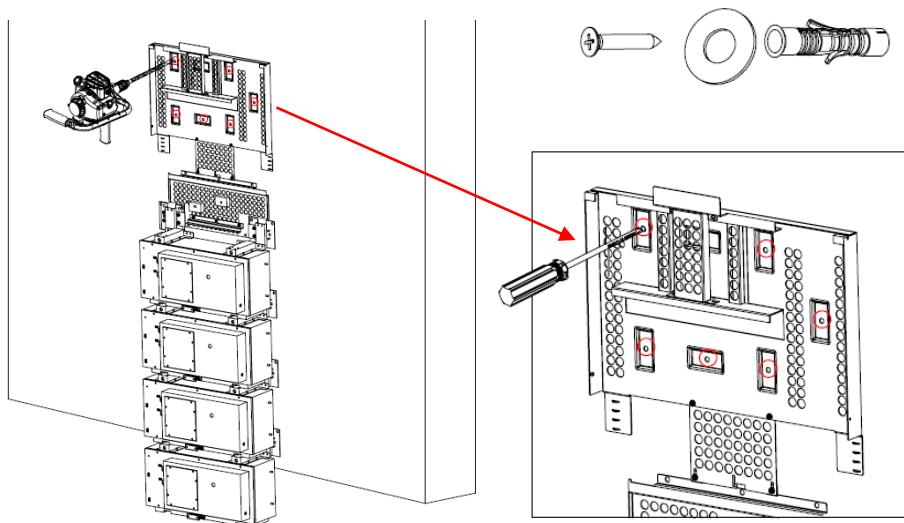

Figure 19 Installation of the Bracket B of the Inverter

Step 11: Cover the PE bag on the top battery to block out the dust before drilling.

Please drill holes directly on the wall at the marking positions of the brackets with an impact drill (bit ϕ 8.0mm, length 20cm), and the depth of each hole is about 7 cm.

Please insert the expansion tube into the drilled hole. Pass the tapping screw through the gasket and lock with a screwdriver, as Figure 19 shows.

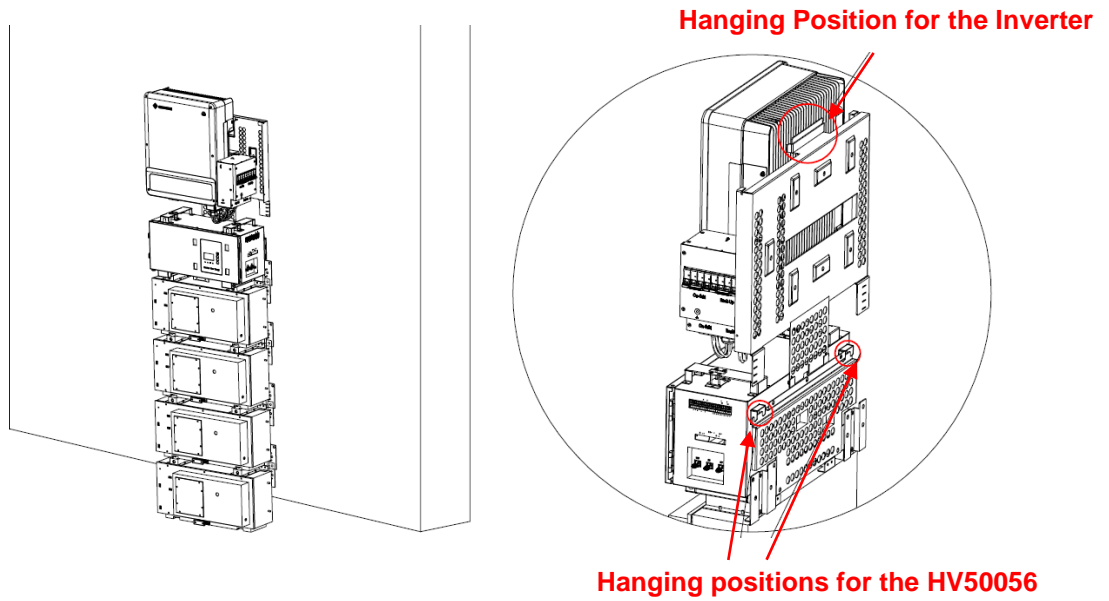

Figure 20 Installation of the HV50056 and the Inverter

Step 12: Please hang the HV50056 on the rear bracket of HV50056 and hang the SMILE-T10-INV on the bracket B of the inverter.

2.3 Wiring

Step 5: Before wiring please remove the front maintenance baffle of the batteries with an across screwdriver.

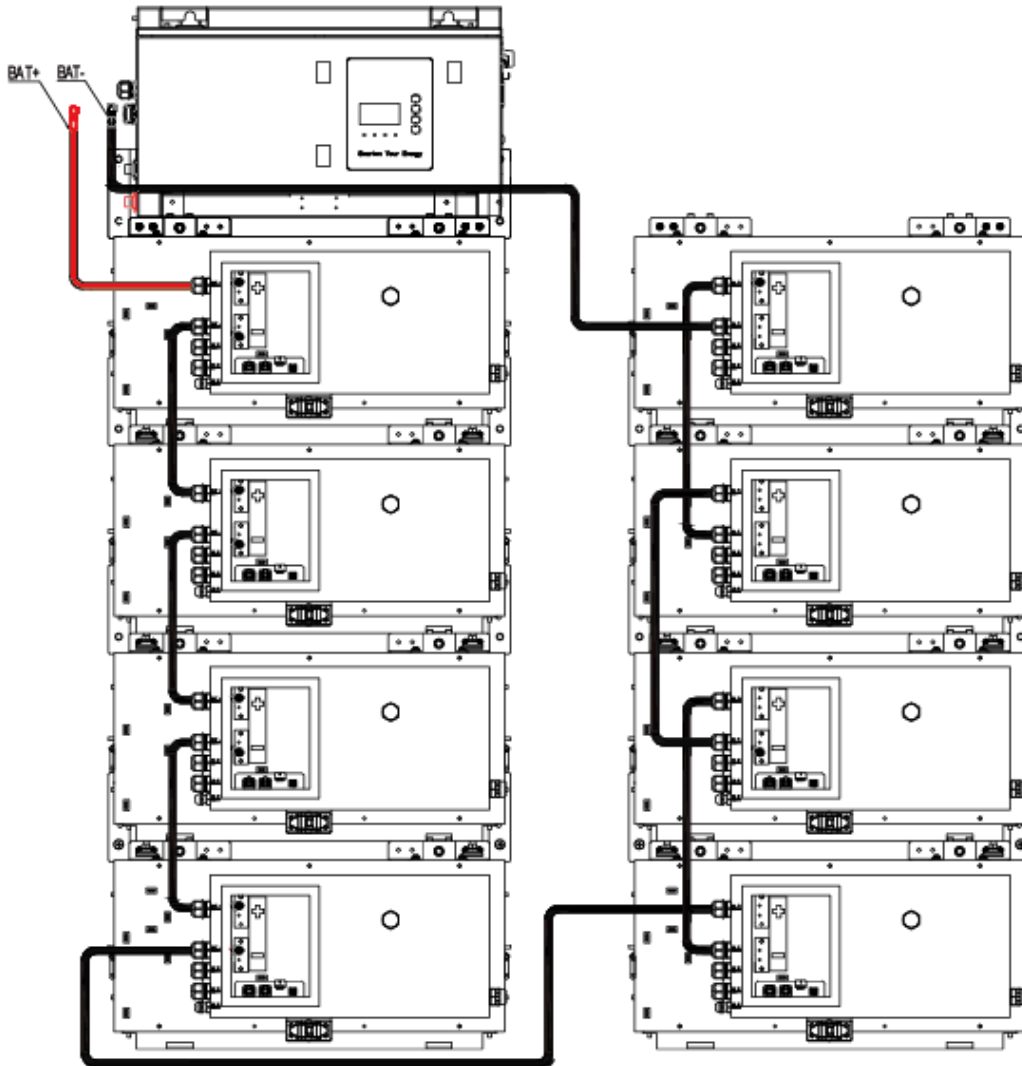

Figure 21 Connection of Power Cables on Battery Side

Step 6: Please connect the power cables as referred in Figure 21 .

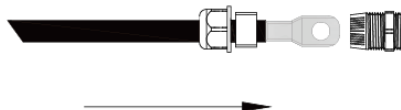

Figure 22 Battery Power Cable

Battery power cable connection sequence:

Through the waterproof cap→through the sealing ring→through the joint, fixed to the copper bar with M5 nut inside of the battery.

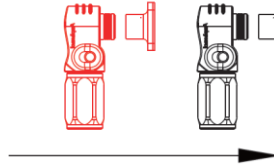

Figure 23 Power Cable Plug Connectors

HV50056 & Battery power cable connection sequence: one side terminal shall through the waterproof cap→through the sealing ring→through the joint of the battery, fixed to the copper bar with M5 nut inside of the battery; The plug connector on the other side shall be connected to the plug port of the HV50056 with the corresponding color. When a crisp sound is heard, the connection is correct.

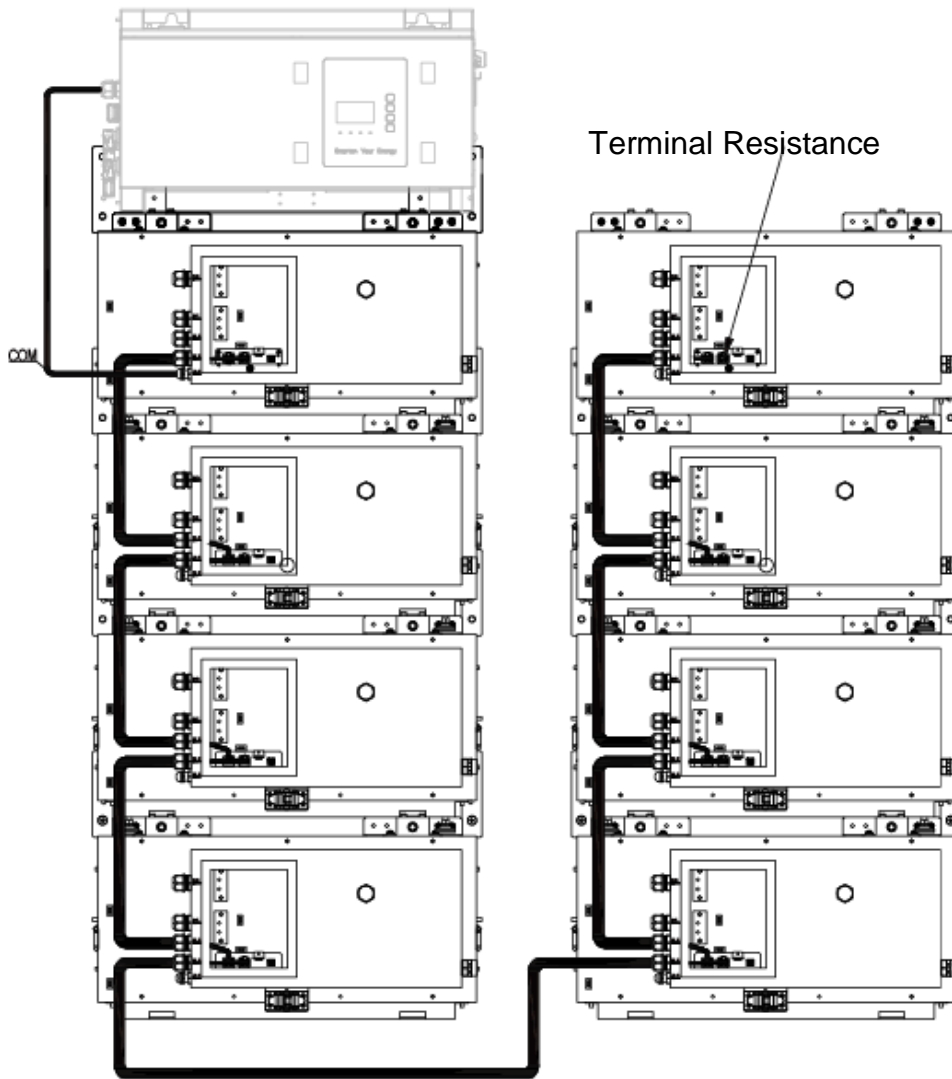

Figure 24 Connection of Communication Cables on Battery Side

Step 7: Please connect the communication cables as referred in Figure 24.

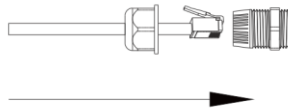

Figure 25 Communication Cables

Battery communication cable connection sequence: the RJ45 connector of the communication cables shall be through the waterproof cap → through the sealing ring → through the joint and inserted in to the COM port inside of the battery.

HV50056 & Battery communication cable connection sequence: the RJ45 connector on one side shall be through the waterproof connector inserted into the

COM port inside the battery which is nearest to HV900112. The RJ45 connector on the other side shall be through the waterproof cover inserted into the LMU port inside the HV50056.

Terminal Resistance: Insert the terminal resistance into the last COM port of the last battery.

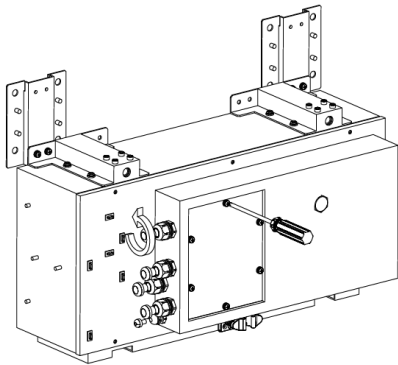

NOTES:

1. To remove the waterproof connector, it shall be rotated counterclockwise according to the installation procedure.
2. Use a screwdriver to remove the maintenance baffle before wiring.
3. The battery has no circuit breaker for protection. Please be careful, do not short the positive and negative terminals during installation.
4. The waterproof sealing ring needs to be confirmed that it shall be inserted into the plastic claw ring during installation.

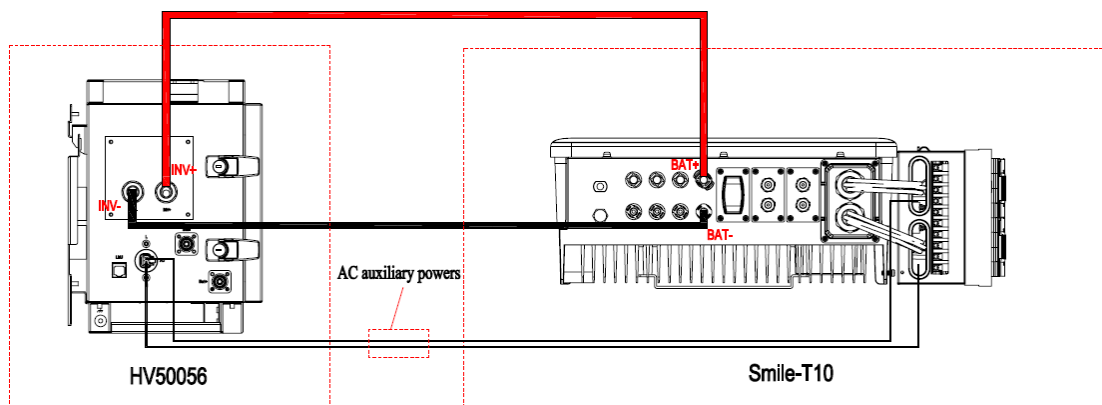

Figure 26 Connection of the Power Cables and AC Auxiliary Cable

Step 8: Please connect one DC power cable from INV+ port on HV50056 to BAT+ port on SMILE-T10-INV, and another DC power cable from INV- port on HV50056 to BAT- port on SMILE-T10-INV. The AC auxiliary power cables which have been prewired onto the inverter, shall be connected to the AC auxiliary port on HV50056, as shown in Figure 26.

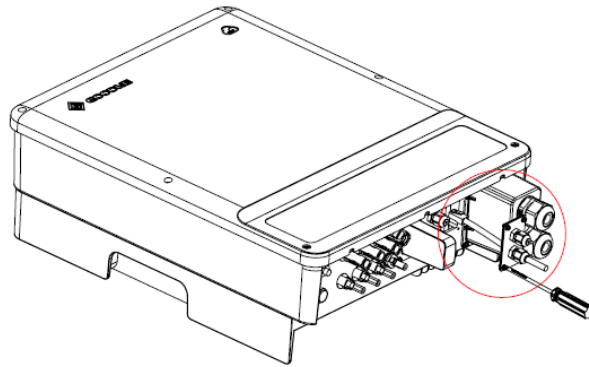

Figure 27 Connection of the Communication Cables on the Inverter Side-Removing Waterproof Baffle

Step 9: Please remove the waterproof baffle of the inverter at first as shown in Figure 27.

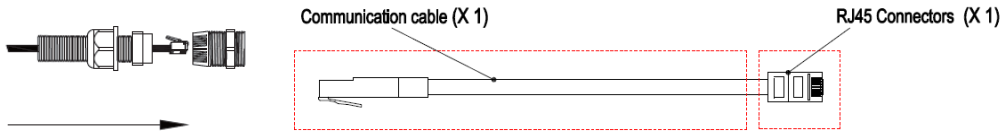

Figure 28 Connection of the Communication Cables on the Inverter Side

Step 10: Please pass the cable through the waterproof cap, the sealing ring and the joint on the baffle, and then connect with an RJ45 connector, see Figure 28.

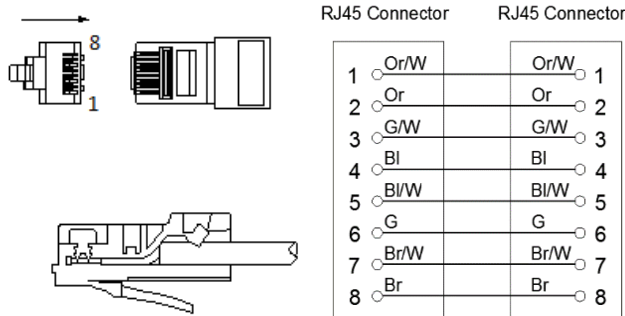

Figure 29 Network Cable Type B

NOTE: The communication cable is in type B, see Figure 29.

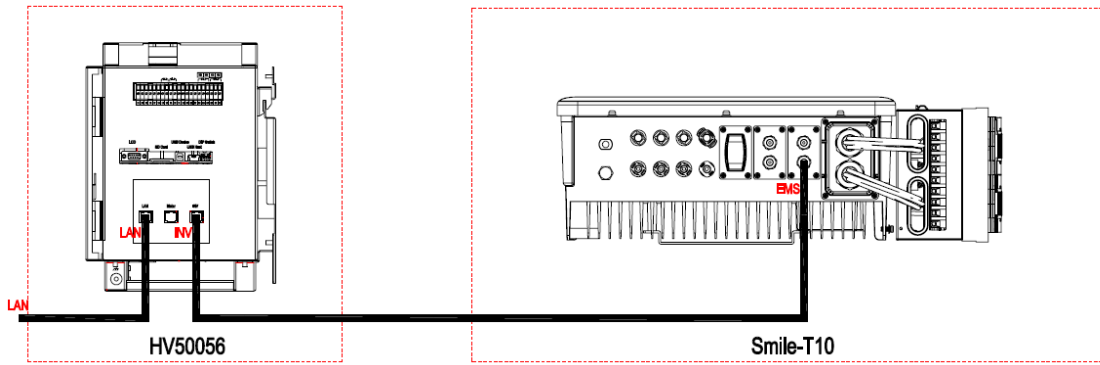

Figure 30 Connection of the Communication Cables on the Inverter Side

Step 11: Connect the communication cable between INV COM port of HV50056 and EMS COM port of the Inverter, as Figure 30 shows.

Step 12: Fix the waterproof baffle back to the inverter and fix the waterproof cap.

NOTE: For indoor user, Step 18 and 20 are not needed. After removing the waterproof baffle, please connect between INV COM port of HV50056 and EMS COM port of the Inverter with a regular 568B network cable.

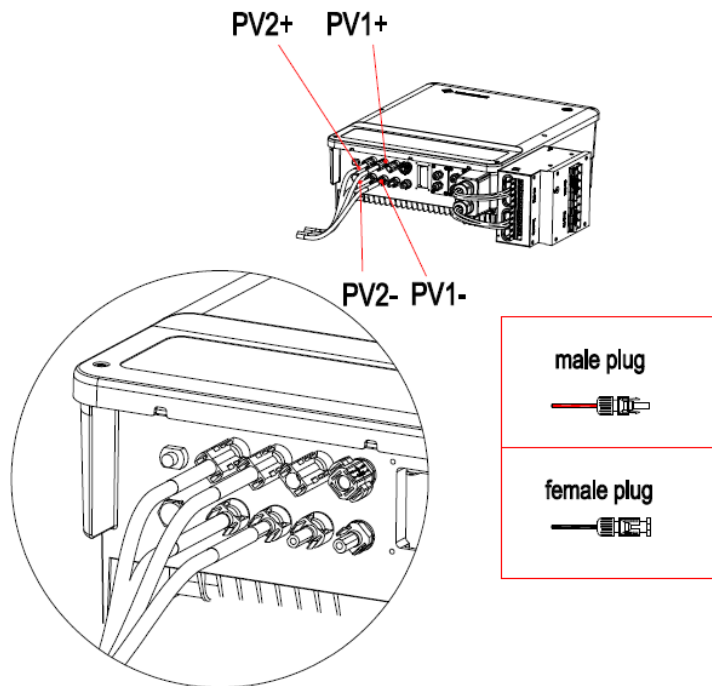

Figure 31 Connection of PV cables

Step 13: Connect the PV MC4 connector to the PV ports of the inverter.

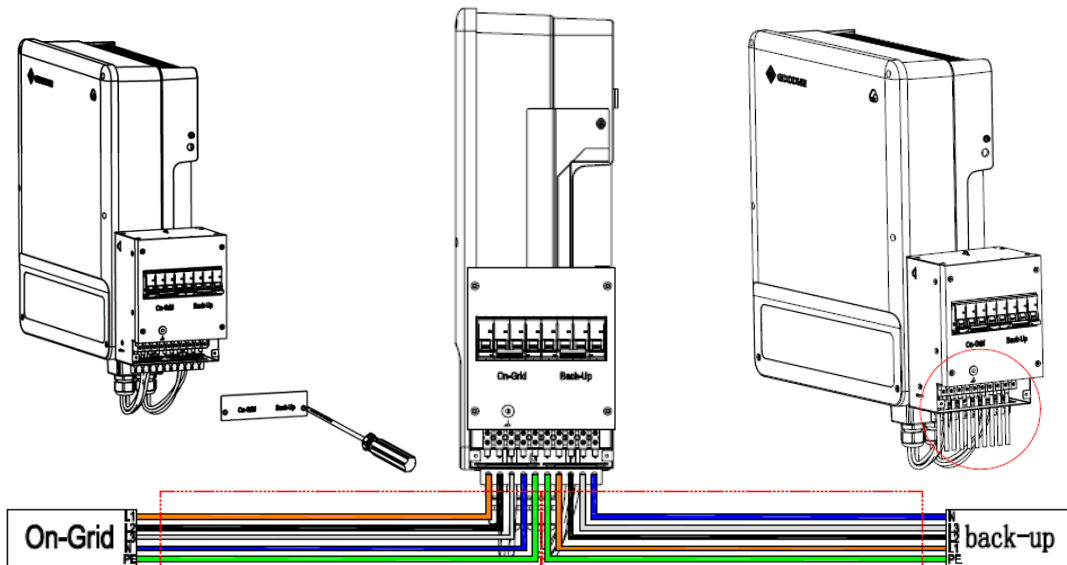

Figure 32 Connection of AC cables

Step 14: Please remove the cover of the cable box. Connect the AC cables to the corresponding ports. Fix the cover back to the cable box, as Figure 32 shows.

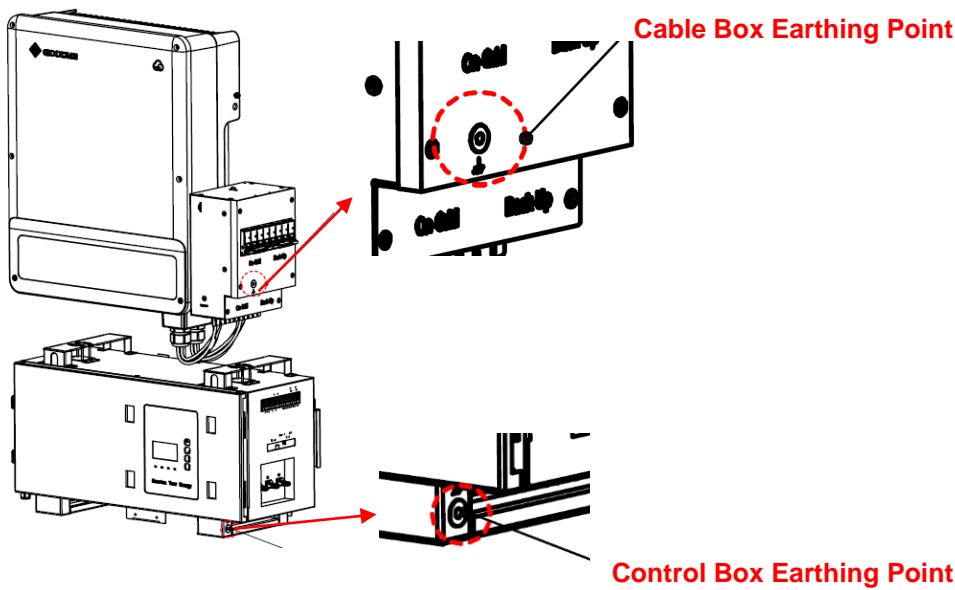

Figure 33 Earthing Points

Step 15: Figure 33 shows the earthing points on the HV50056 and cable box. Please connect them to the grounding copper bar of the customer.

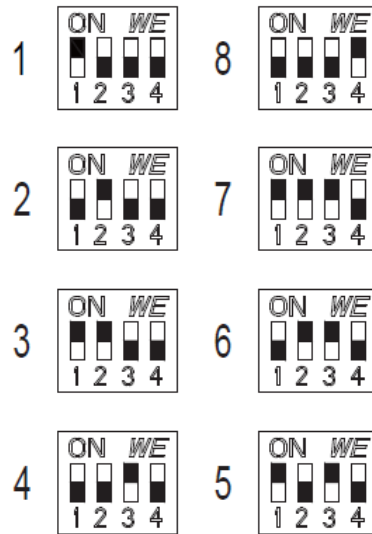

Figure 34 DIP Switch Definition

Step 16: DIP switch defines the ID address of each battery in one cluster. Set the DIP switch of the nearest battery from the HV50056 to the farthest battery in sequence of 1 to N. N is the number of the batteries, which is min. 4 and max. 8.

Note: There should be no same ID number in one cluster.

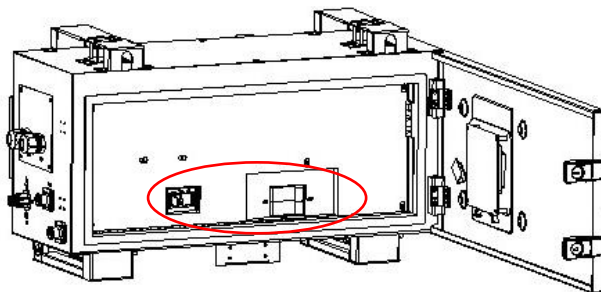

Figure 35 Turning on the Switch

Step 17: After wiring, please open the front cover of HV50056 and turn on the molded case circuit breaker.

2.4 Power Meter

The power meter should be installed and connected in the distribution box. There are two kinds of power meters, ADL-3000 and ACR10R, which users can choose from.

- **ADL-3000:** three-phase meter (with or without CT)
- **ACR10R:** three-phase meter with CT

2.4.1 Meter ADL-3000 (If Applicable)

2.4.1.1 ADL-3000 (without CT, without meter plug), if applicable:

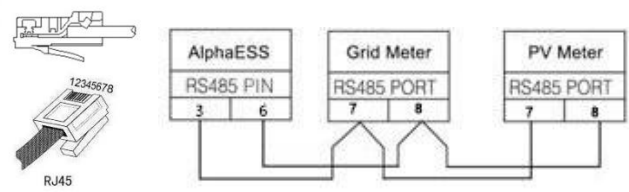
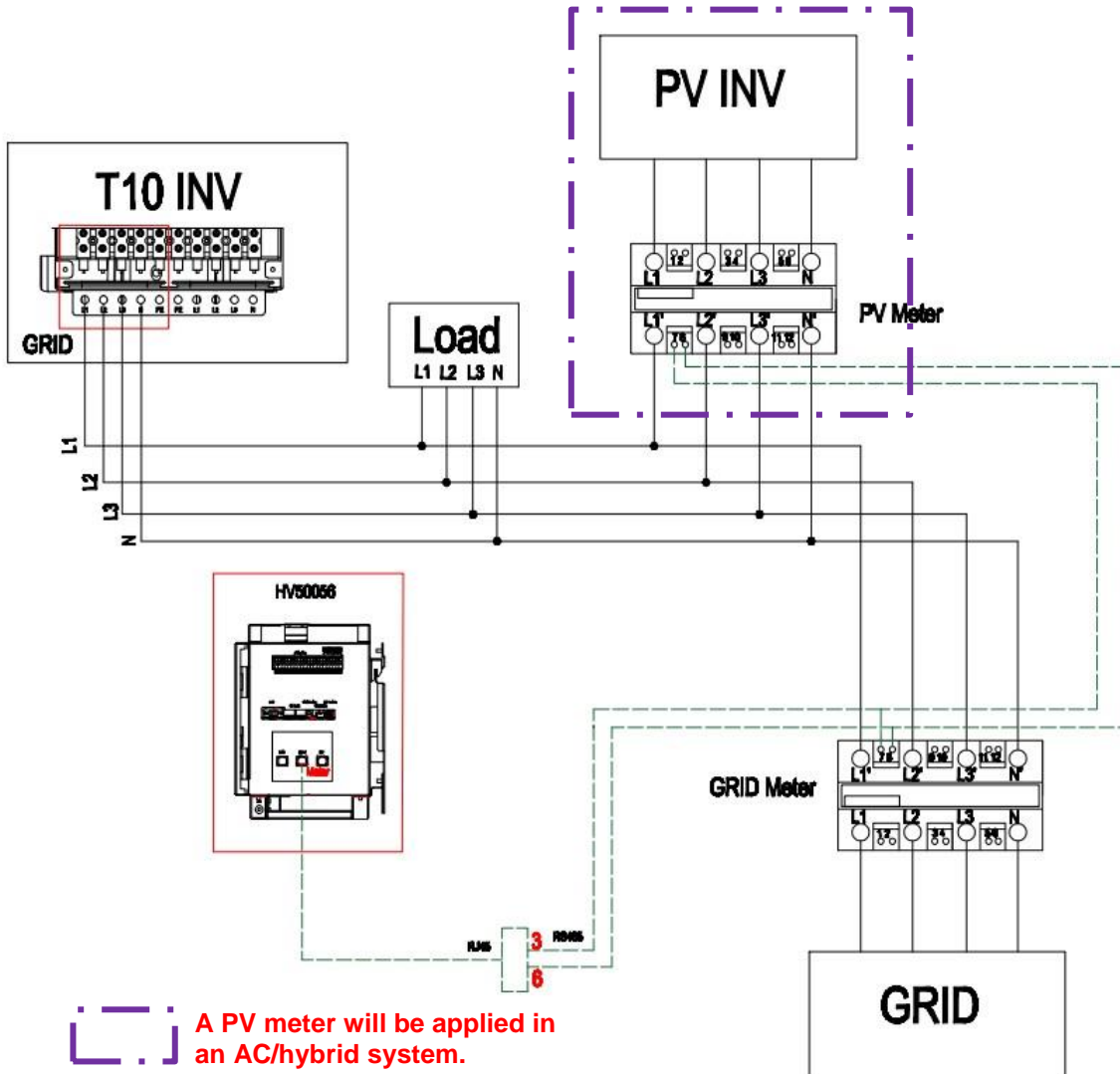

Figure 36 ADL-3000 Connection (without CT, without Meter Plug)

i NOTE: Meter 7, 8 connect the RJ45 3, 6, then RJ45 connect the Meter port on the control box.

2.4.1.2 ADL-3000 (without CT, with meter plug), if applicable:

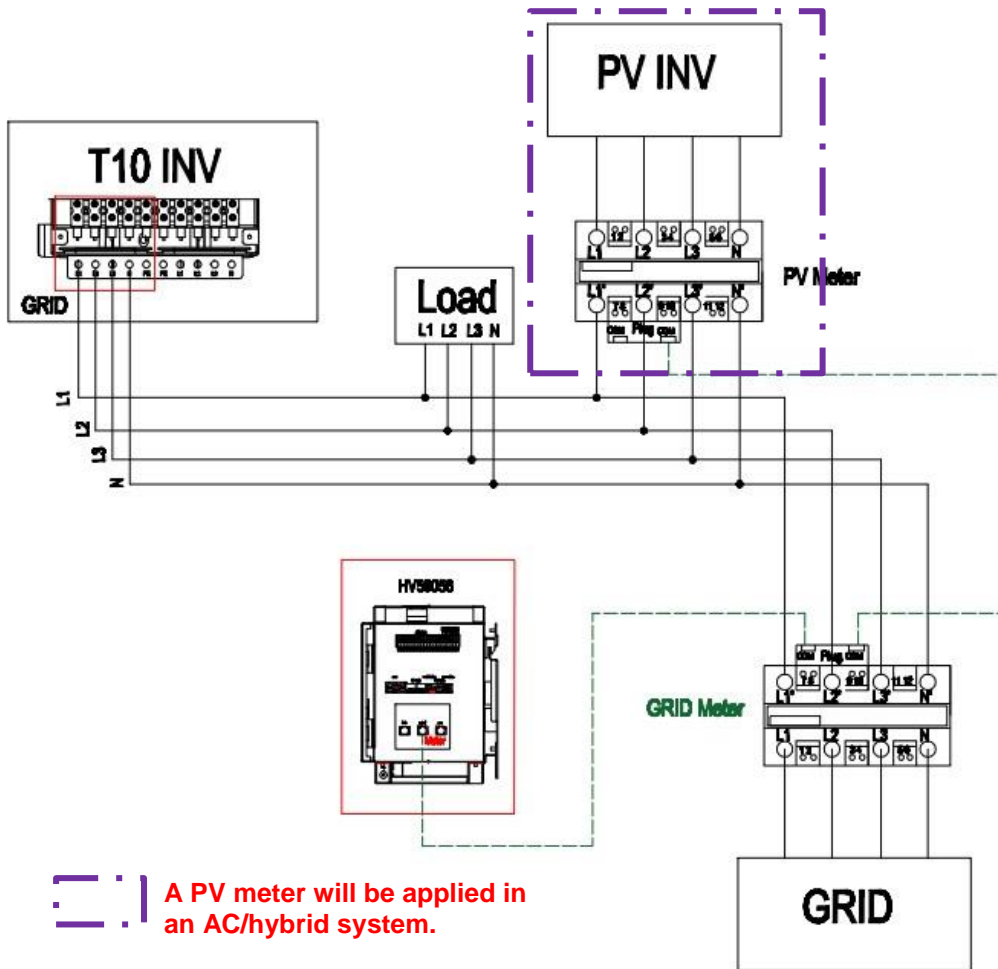

Figure 37 ADL-3000 Connection (without CT, with Meter Plug)

2.4.1.3 ADL-3000 (with CT, without meter plug), if applicable:

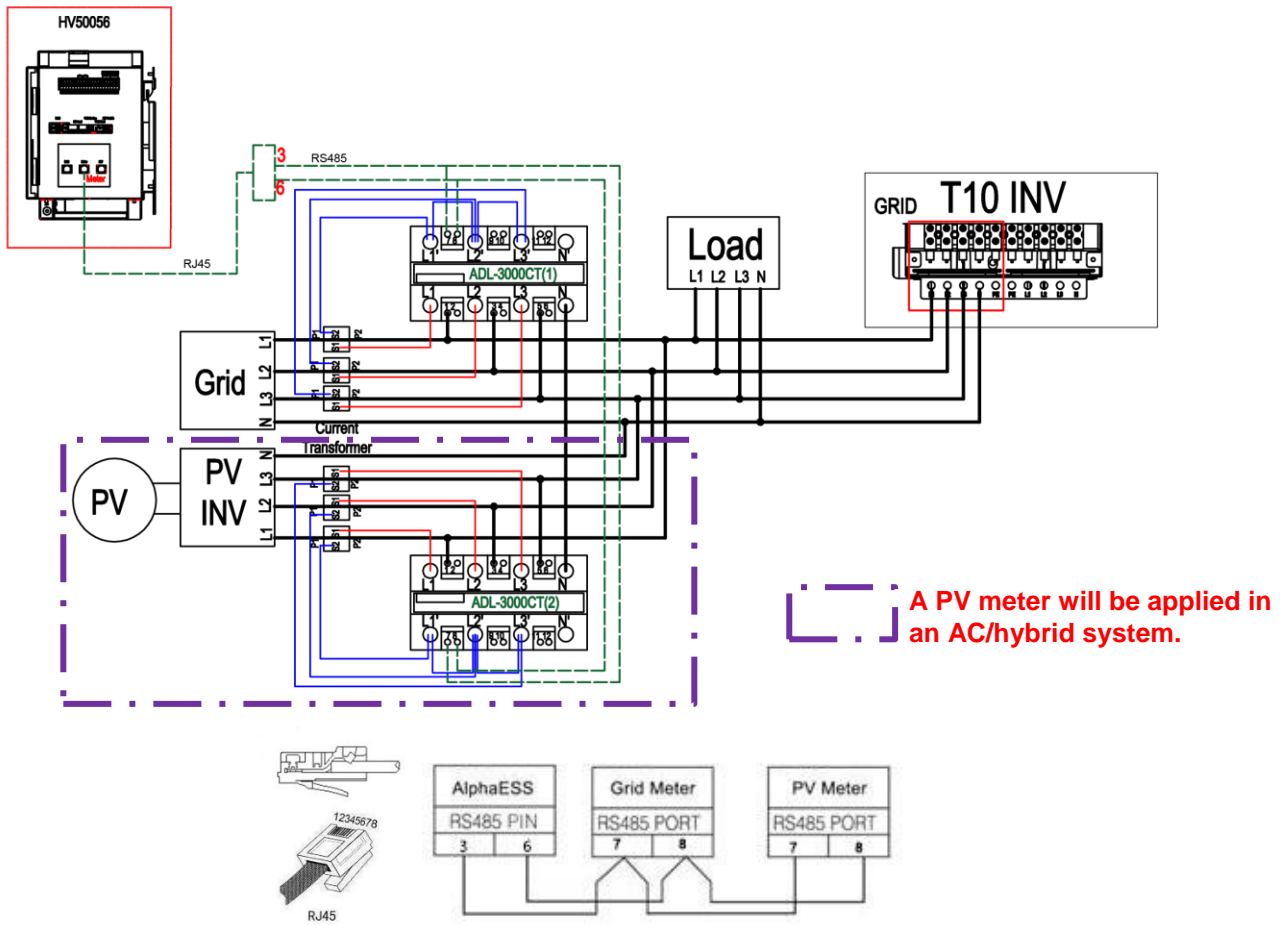

Figure 38 ADL-3000 Connection (with CT, without Meter Plug)

Note: When connecting CTs, pay attention to the current direction. P1 should be nearest to the grid or the PV-inverter.

2.4.1.4 ADL-3000 (with CT, with meter plug), if applicable:

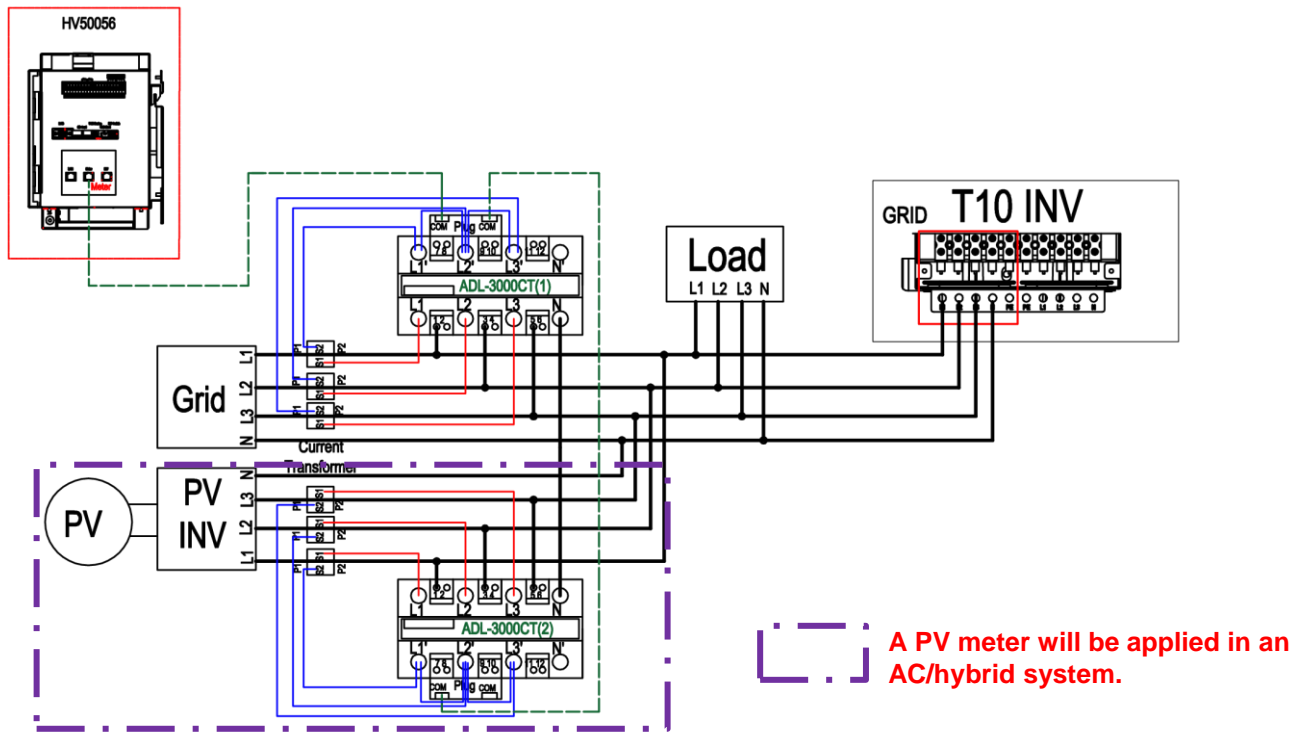
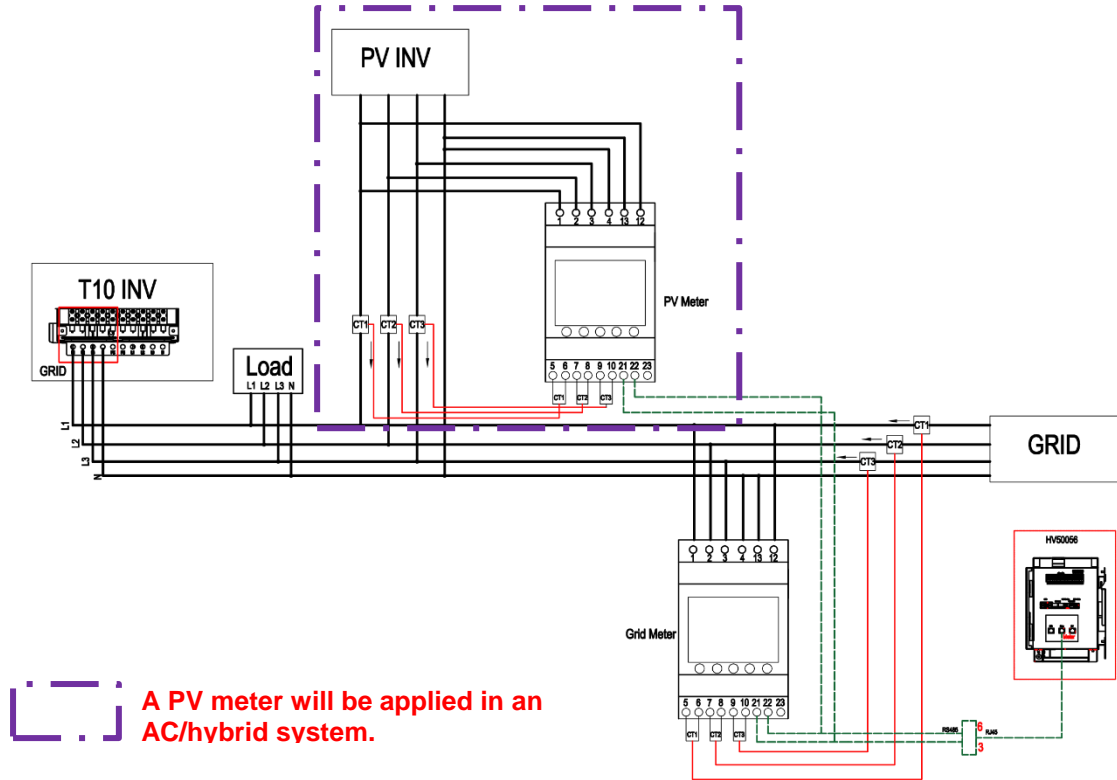

Figure 39 ADL-3000 Connection (with CT, with Meter Plug)

i Note: When connecting CTs, pay attention to the current direction. P1 should be nearest to the grid or the PV-inverter.

2.4.2 ACR10R Meter (If Applicable)



A PV meter will be applied in an AC/hybrid system.

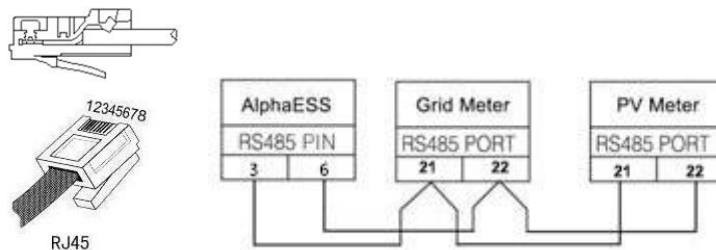

Figure 40 ACR10R with CT Connection (without Meter Plug)

Note: When connecting CTs, pay attention to CT arrow directions, please refer to Figure 40.

2.4.3 Meter setting

2.4.3.1 ADL3000

Step 1: The initial interface of the meter (normal working interface) is as shown below:

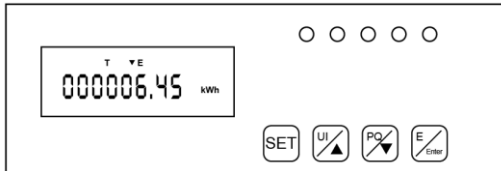

Step 2: Click the "SET" button to enter the password interface:

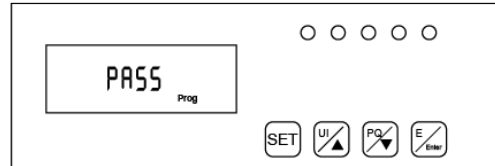

Step 3: Click the "Enter" button to enter the following interface, and press the up and down arrow keys to enter the password 0001;

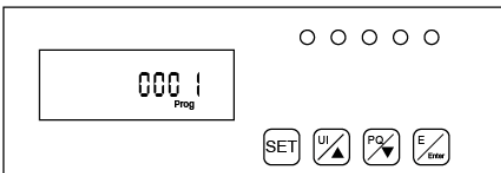

Step 4: Click the "Enter" button and the password input is completed.

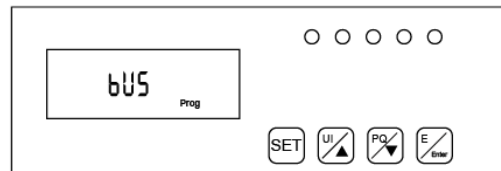

Step 5: Click the "Enter" button again to enter the address interface:

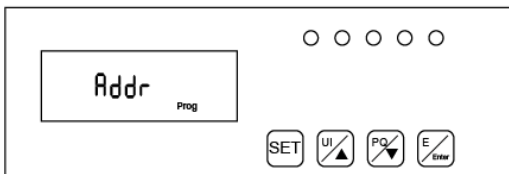

Step 6: Click the "Enter" button to enter the following interface, press the up and down arrow keys to set the meter address, the Grid meter (DC, AC and Hybrid system) address is set to 001, and the PV meter (AC and Hybrid system) address is set to 002.

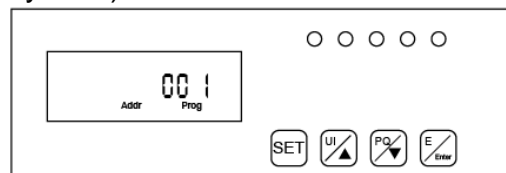

Step 7: Click the "Enter" button and the address setting is completed.

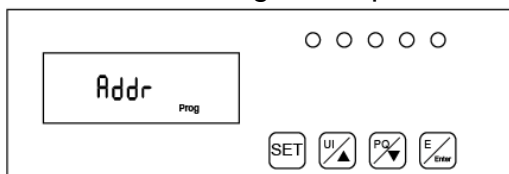

Step 8: Click the "SET" button to enter the following interface:

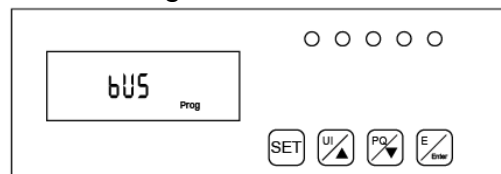

Step 9: Click the "SET" button again to enter the save interface:

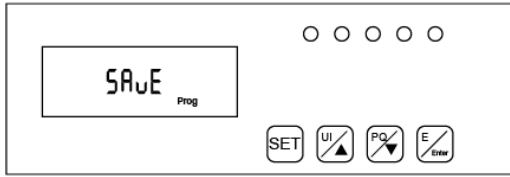

Step 10: Click the "Enter" button to enter the following interface, press the up and down arrow keys, and set "no" to "YES" to save the configuration.

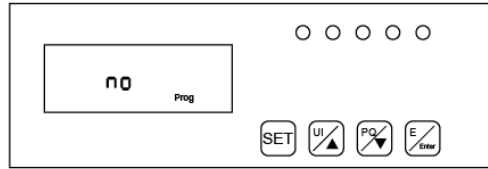

Step 11: Click the "Enter" button and the setting ends.

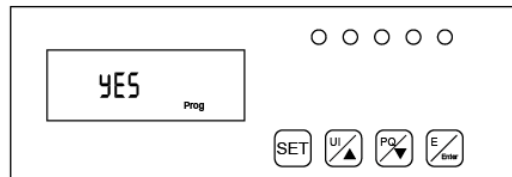

2.4.3.2 ACR10R

Step 1: This is the initial interface of the meter, click the "Set" button;

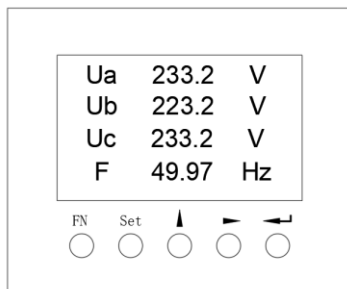

Step 2: Click the "SETUP" button;

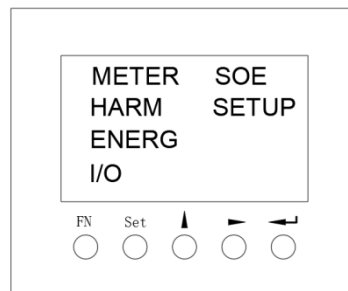

Step 3: On the password input interface, the code is "0001", confirm entering the setting interface;

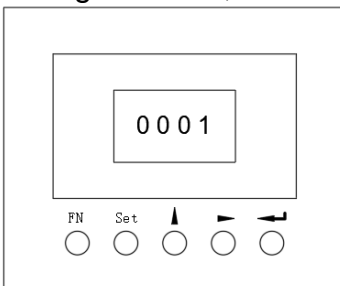

Step 4: In the setting interface, select "Comm" option, enter the communication setting interface;

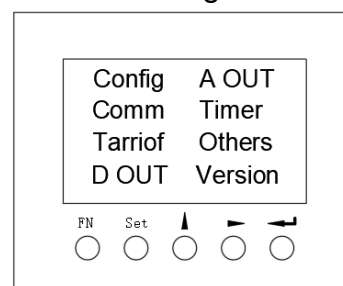

Step 5: Set the communication address and communication baud rate in the communication setting interface. When the meter is used as the Grid meter (DC, AC/Hybrid system), the address is set to "005". When it is used as the PV meter

(AC/Hybrid system), the address is set to “006”. The baud rate is set to 9600;

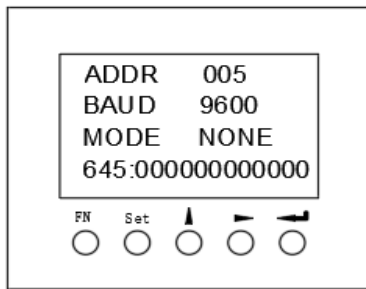

3. System Operation

3.1 Switch on

System shall be turned on in the correct sequence to avoid any damage.

- Step 1:** Turn on the MCCB of HV50056 as Step 25 shows.
- Step 2:** Turn on the On-grid AC breaker of the cable box
- Step 3** Turn on the PV switch of the inverter
- Step 4** If backup load is applied, turn on the Backup AC breaker of the cable box

3.2 Switch off

System shall be turned off in the correct sequence to avoid any damage.

- Step 1:** Remove the front panel of the inverter and HV50056
- Step 2:** If backup load is applied, turn off the Backup AC breaker.
- Step 3:** Turn off the MCCB of HV50056.
- Step 4:** Turn off the PV switch of the inverter
- Step 5:** Turn off the On-grid AC breaker.

4. EMS Introduction and Set up

4.1 Function Description

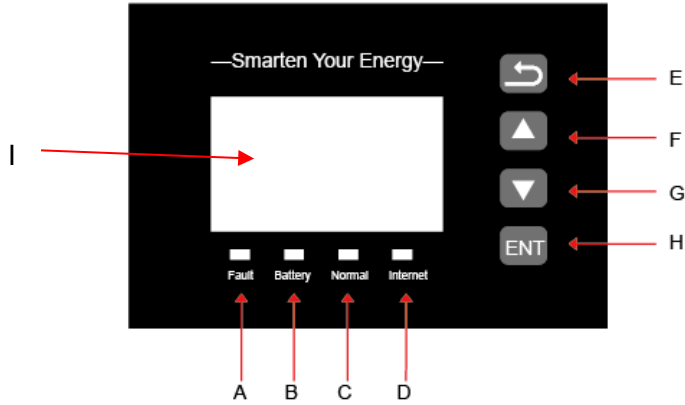









Figure 41 SMILE-T10 EMS Interface

Item	Name	Status	Description
A	Fault		ON: Fault
			OFF: No Fault
B	Battery		ON: Battery communication is OK
			OFF: Battery communication is lost
C	Normal		ON: System works normally
			OFF: System is abnormal or warning
D	Internet		ON: System is communicated with server
			OFF: System is not communicated with server

Object	Name	Description
E	Button Function	Return Button: Escape from current interface or function

F		Up button: Move cursor to upside or increase value.
G		Down Button: Move cursor to downside or decrease value.
H		ENT Button: Confirm the selection.
I	LCD Screen	Display the information of the inverter in this LCD screen.

4.2 Setting

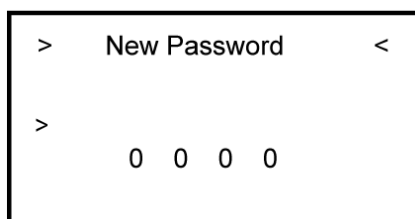

Figure 42 Password Interface

Step 1: Click setting and enter the password.

The installation's password is four-digit password: 1111, after the password is correctly input, you can enter into the main Setting interface (administrator permissions).

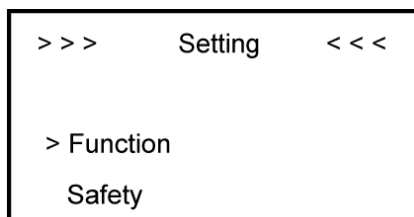

Figure 43 Setting Menu

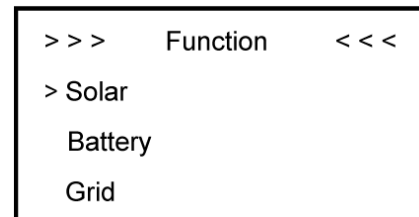

Figure 44 Function Interface

Step 2: Click Function to enter function setting.

Step 3: Click Solar to set the Solar relevant information.

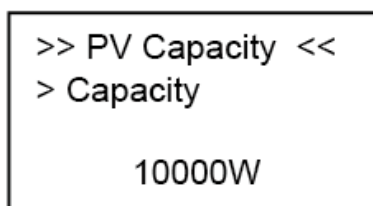

Figure 45 Solar Setting Interface

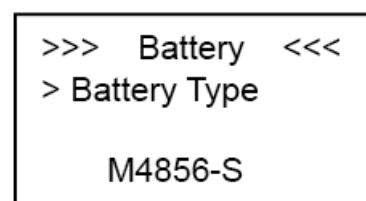

Figure 46 Battery Model Interface

Step 4: Set PV capacity.

Step 5: Click the Battery Function and check battery type M4856-S.

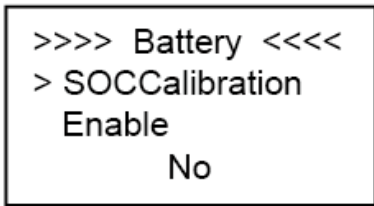

Figure 47 SOC Calibration Interface

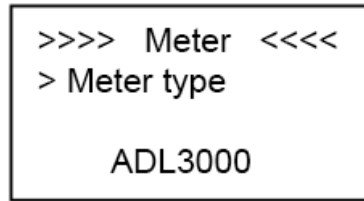

Figure 48 Meter Option Interface

Step 6: Check SOC Calibration function set No.

Step 7: Choose the type of meter.



Figure 49 Grid Setting Interface

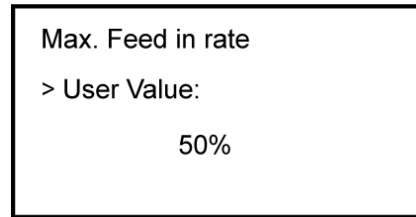

Figure 50 Max. Feed in rate Setting Interface

Step 8: Click the Grid Function to set up relevant parameters about the grid.

Step 9: Set the Max. Feed in rate value.

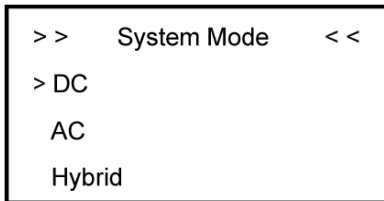

Figure 51 System Mode Setting Interface

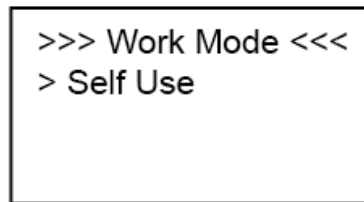

Figure 52 Work Mode Setting Interface

Step 10: Click Function-System Mode to set system mode: DC, AC, Hybrid.

Step 11: Click the mode then set up work mode.(self-use or force time charge)

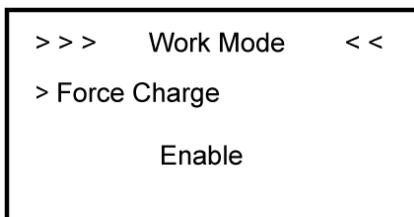

Figure 53 Force Charge Setting Interface

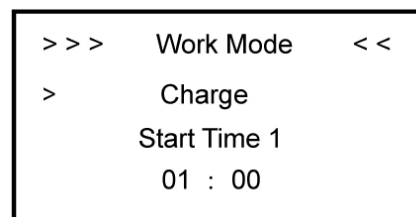
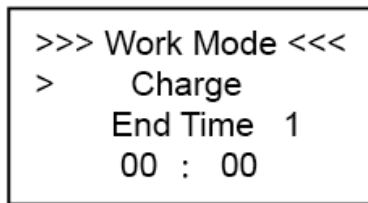
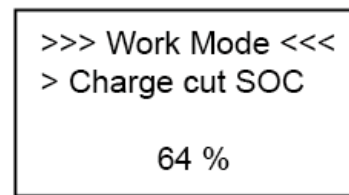
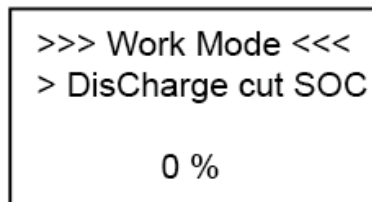
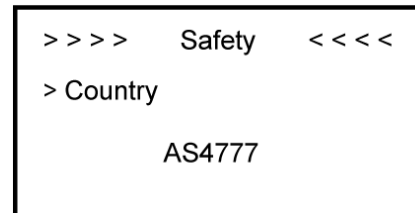

Figure 54 Force Charge Start Time Setting

Step 12: If you want to use force charge, sett Enable here.

Step 13: Set the charge start time

Figure 55 Force Charge End Time Setting

Figure 56 Charging cut SOC Setting
Step 14: Set the charge start time
Step 15: Set the charging cut SOC.

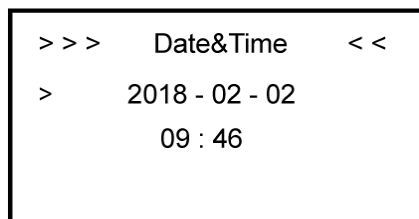
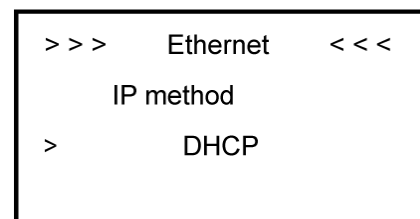
Figure 57 Discharging cut SOC Setting

Figure 58 Safety Setting Interface
Step 16: Set the discharging cut SOC.
Step 17: Click Safety in the setting menu. Set safety standard.

ARN4105 for Germany, CEI0_21 for Italy, G83_2 for Great Britain

Figure 59 Date&Time Setting Interface

Figure 60 Ethernet interface

Step 18: Click System in the setting menu. Click Date & Time and set up the date and time.

Step19: Click Ethernet to set the IP address. DHCP mode means that setup IP address is set up automatically.

If you want to set up the IP address manually, please choose manual mode.

i NOTE: It is needed to set the following 3 parameters for manual mode:

IP Address: IP address;

Subnet Mask: Subnet mask;

Default Gateway: Default gateway;

Automatic display one parameter:

MAC Address: display MAC Address.

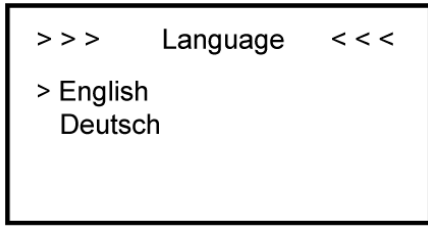

Figure 61 Date&Time Setting Interface

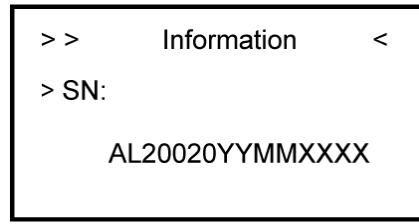

Figure 62 Date&Time Setting Interface

Step 20: Click Language to set language

Step 21: Make sure all the following number is correct.

4.3 EMS Communication Checking

After wiring and EMS setting, check that the status indicators are normal. Then enter MENU->Status->Communication

to check that the communication status of all the devices are normal.

AC\HYBRID system:

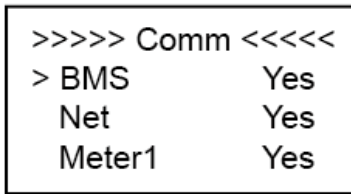

Figure 63 BMS

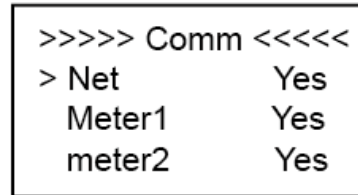

Figure 64 Ethernet and Meter

DC system:

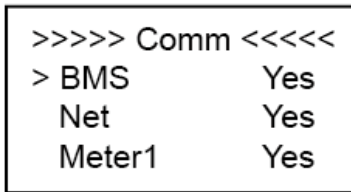

Figure 65 BMS

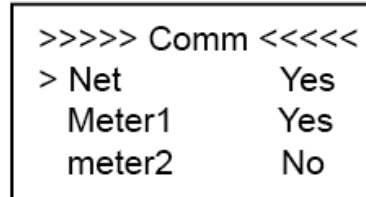

Figure 66 Ethernet and Meter

In an AC/Hybrid mode, the Meter 2 status shows YES, which means normal. In a DC mode, the Meter 2 status shows YES, which means normal. Then EMS can work normally.

4.4 Assembling of the Front Panels

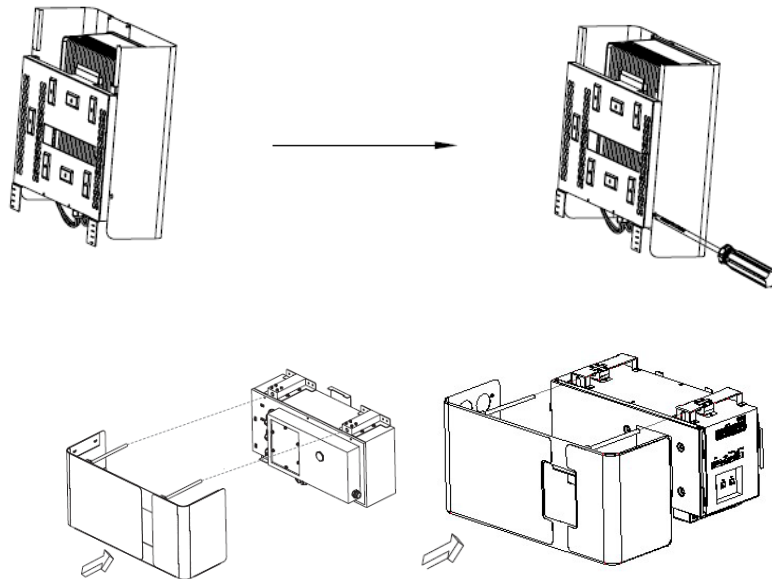

Figure 67 Assembling of the Front Panels

Step 18: Inverter part: please unscwer the scwews of Bracket A and hang the front panel of the inverter onto Bracket B. Fix the front panel to Bracket B with scwews.

Battery and control box: Push the top two guide rods into the housing and press the buckle from the bottom right in the middle.

NOTE: please assemble the front panel of the inverter at first, then HV50056 and the batteries.

5. Online Monitoring

You have to create a new account on our webserver for the normal monitoring. So please use the following steps:

Open the portal: www.alphaess.com.

Enter the username and password, then click “Login” to jump to the home page. There will be a prompt after a failed login.

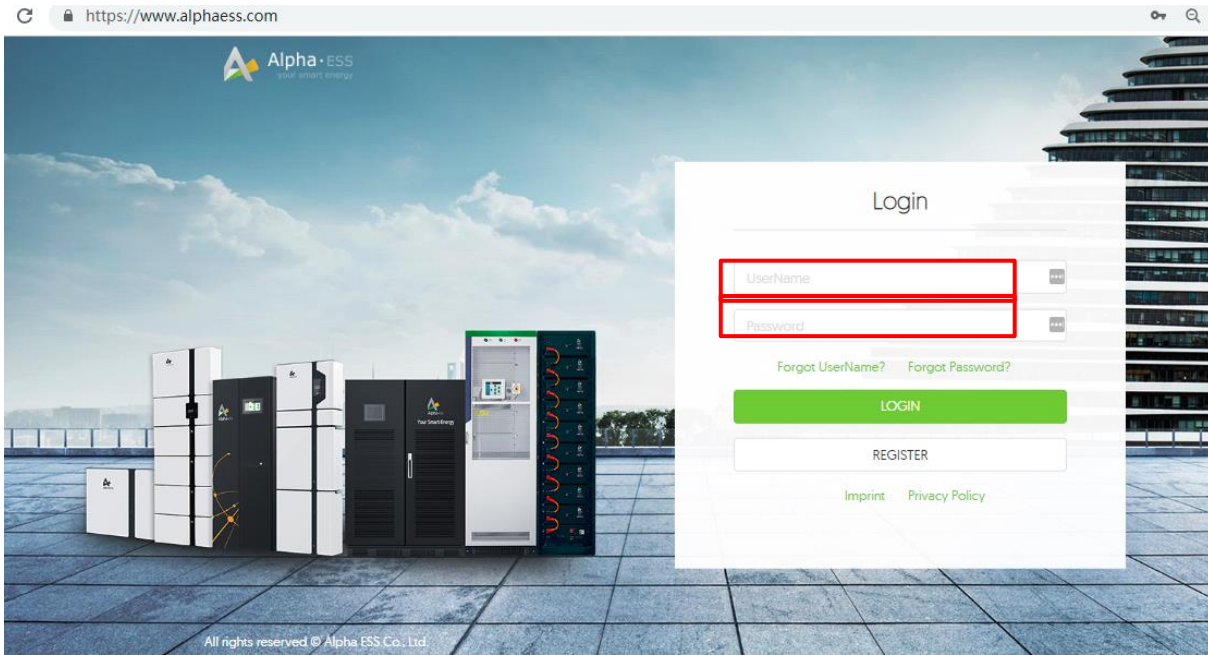
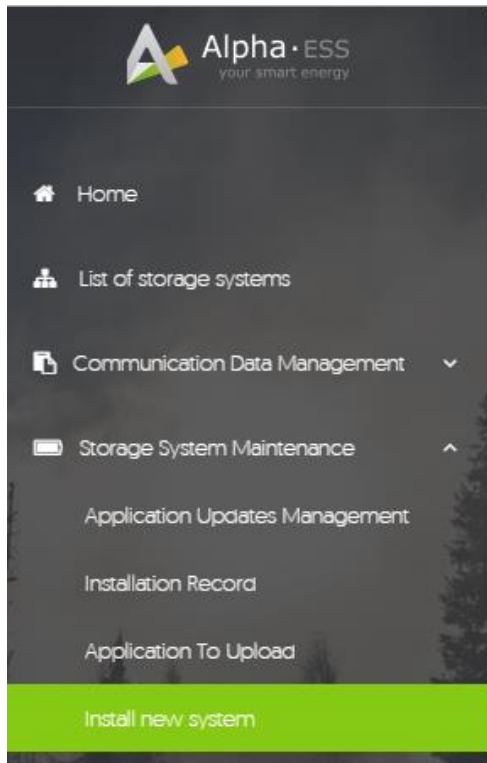

Figure 68 Monitoring Login Interface

Users who haven't yet registered need to click “Register” to visit the registration page: (as shown below)

Boxes followed by a “*” mark must be filled, and the contents you fill must consist with the facts. Registered users come in 2 types: end users and installers. Please choose between them according to the actual situation. Then you can check whether you need auto upgrade or not according to your own situation. Then Click “SIGN UP NOW” to go to the login page.

More detailed information can be obtained in Online Monitoring Webserver installation Manual.



Click install new system to register the license.

Install new system

* S/N	* Check Code	* License No.
<input type="text"/>	<input type="text"/>	<input type="text"/>
* Installation Date	* Client Full Name	* Contact Number
<input type="text"/>	<input type="text"/>	<input type="text"/>
* Contact address		
<input type="text"/>		
Remark		
<input type="text"/>		
Attachment		
<input type="button" value="Choose File"/> No file chosen		

Figure 74 System Registering Interface

Input **S/N**, **Check Code**, **License No.**, **Date**, **Name**, and **Contact No.** to complete the registering process.

6. Annex

6.1 Datasheet – AlphaESS Storion-SMILE-T10

System Specification			
Model	Storion-SMILE-T10*		
Nominal Output Power	10 000 VA		
Max. DC Input Power	13 000 W		
Capacity Range	11.5 kWh ~ 23.0 kWh (90% DoD)		
Battery Chemistry	LFP (LiFePO4)		
IP Protection	IP21 (Indoor) / IP65 (Outdoor)		
Warranty	5 Year Product Warranty, 10 Year Performance Warranty		
Inverter Technical Specification			
Model	SMILE-T10-INV	Max. AC Output Current	16.5 A
Max. PV Input Current	12.5 / 12.5 A	Max. AC Input Current	22.7 A
Max. PV Input Voltage	1000 V	Output Power Factor	1 (Adjustable from 0.8 leading to 0.8 lagging)
Max. Short Current	15.2 A	Backup	UPS
MPPT Number	2	Display	LCD (in HV50056)
MPPT Voltage Range	200 ~ 850 V	Humidity	15% ~ 85% (No Condensing)
Start-up Voltage	180V	Dimension (WxDxH)	610 x 236 x 605 mm
Max. Charge/Discharge Current	25 A	Weight	40 kg
Phase	Three-Phase	Grid Regulation	CEI 0-21, VDE4105-AR-N, EN50438, G83/2, G100
Rated Voltage	400 / 380 V	Safety	IEC 62109-1&-2, IEC 62040-1
Rated Frequency	50 / 60 Hz	EMC	EN61000-6-1, EN61000-6-2, EN61000-6-3, EN61000-6-4, EN61000-4-16, EN61000-4-18, EN61000-4-29
Battery Technical Specification			
Module Model	M4856-S		
Module Capacity	2.9 kWh		
Module Nominal Voltage	51.2 V		
Operating Temperature Range	-10 °C ~ 50 °C**		
Module Weight	42 kg		
Module Dimension (W x D x H)	610 x 236 x 303 mm		
Cycle Life	≥ 6000		
Max. Charge/Discharge Current	56 A (1C)		
High Voltage Control Box Technical Specification			
BMU Model	HV50056		
DC Voltage Range	179 ~ 465 V		
Nominal Output Current	56 A		
Battery Modules Connection	4 ~ 8 M4856-S in series		

* except Australia

**When the temperature is below 0 °C or above 40 °C, the performance will be limited.