

**Fronius Primo GEN24**  
**3.0 / 3.0 Plus / 3.6 / 3.6 Plus**  
**4.0 / 4.0 Plus / 4.6 / 4.6 Plus**  
**5.0 / 5.0 Plus / 6.0 / 6.0 Plus**

EN

Operating instructions



# Contents

|   |           |
|---|-----------|
| Safety rules.....   | 7         |
| Explanation of safety notices.....  | 7         |
| Safety .....  | 7         |
| General .....   | 7         |
| Environmental conditions.....   | 8         |
| Qualified personnel.....  | 8         |
| Noise emission values.....  | 8         |
| EMC measures.....   | 8         |
| Backup power .....  | 9         |
| Data protection.....  | 9         |
| Copyright.....  | 9         |
| Protective earthing (PE).....   | 10        |
| <b>General information</b> .....  | <b>11</b> |
| Fronius Primo GEN24.....  | 13        |
| Device concept.....   | 13        |
| Function overview .....   | 13        |
| Fronius UP.....   | 13        |
| Scope of supply .....   | 14        |
| Intended use.....   | 14        |
| Thermal concept.....  | 15        |
| Fronius Solar.web.....  | 15        |
| The various operating modes.....  | 16        |
| Operating modes – Explanation of symbols .....  | 16        |
| Operating mode – Inverter with battery .....  | 17        |
| Operating mode – Inverter with battery and several Smart Meters.....                    | 17        |
| Operating mode - inverter with battery, AC-coupled to another inverter .....            | 18        |
| Operating mode – Inverter with battery and backup power function.....                   | 18        |
| Operating mode – Inverter with battery, Ohmpilot and backup power function.....         | 18        |
| Operating mode – Inverter with battery, further inverter and backup power function..... | 19        |
| Energy flow direction of the inverter.....  | 19        |
| Operating states (only for systems with a battery).....                                 | 20        |
| Energy saving mode .....  | 21        |
| General.....  | 21        |
| Switch-off conditions .....   | 21        |
| Switch-on conditions .....  | 21        |
| Special case .....  | 21        |
| Indication of energy saving mode .....  | 22        |
| Suitable battery.....   | 23        |
| BYD Battery-Box Premium .....   | 23        |
| Protection of people and equipment.....   | 25        |
| Central grid and system protection.....   | 25        |
| WSD (wired shutdown).....   | 25        |
| RCMU.....   | 25        |
| Surge protective device.....  | 25        |
| Control elements and connections .....  | 26        |
| Connection area .....   | 26        |
| Connection area divider .....   | 27        |
| Ground electrode terminal .....   | 27        |
| DC disconnecter .....   | 28        |
| Data communication area.....  | 28        |
| Internal schematic connection diagram of the IOs.....                                   | 29        |
| <b>Backup power variant - PV Point (OP)</b> .....                                       | <b>31</b> |
| General .....   | 33        |
| PV Point (OP).....  | 33        |
| Explanation - PV Point (OP).....  | 33        |

|  |           |
|--|-----------|
| <b>Backup power variant - Full Backup</b>  | <b>35</b> |
| General  | 37        |
| Prerequisites for backup power mode  | 37        |
| Transitioning from feeding energy into the grid to backup power mode                             | 37        |
| Transitioning from backup power mode to feeding energy into the grid                             | 37        |
| Backup power and energy saving mode  | 37        |
| Cabling variants including backup power circuits with 1-pin separation e.g. Austria or Australia | 39        |
| Functions  | 39        |
| Transitioning from feeding energy into the grid to backup power mode                             | 39        |
| Transitioning from backup power mode to feeding energy into the grid                             | 39        |
| All-pin separation cabling variant, e.g. Germany, France, Spain, UK                              | 40        |
| Functions  | 40        |
| Transitioning from feeding energy into the grid to backup power mode                             | 40        |
| Transitioning from backup power mode to feeding energy into the grid                             | 41        |
| All-pin split separation cabling variant (Italy)   | 42        |
| Functions  | 42        |
| Transitioning from feeding energy into the grid to backup power mode                             | 42        |
| Transitioning from backup power mode to feeding energy into the grid                             | 43        |
| <b>Installation</b>  | <b>45</b> |
| General  | 47        |
| Quick-lock system  | 47        |
| Warning notices on the device  | 47        |
| Installation location and position   | 50        |
| Choosing the location of the inverter  | 50        |
| Choosing the location of third-party batteries   | 51        |
| Explanation of symbols for the installation position   | 52        |
| Install the mounting bracket and hang up the inverter  | 54        |
| Selecting the fixing material  | 54        |
| Properties of the mounting bracket   | 54        |
| Do not deform the mounting bracket   | 54        |
| Fitting the mounting bracket to a wall   | 54        |
| Installing the mounting bracket on a mast or beam  | 55        |
| Attaching the mounting bracket to mounting rails   | 55        |
| Attaching the inverter to the mounting bracket   | 56        |
| Prerequisites for connecting the inverter  | 57        |
| Permitted cables   | 57        |
| Permitted cables for the data communication area   | 58        |
| Cross section of the AC cable  | 58        |
| Cross section of the DC cable  | 59        |
| Maximum alternating current fuse protection  | 59        |
| Connecting the inverter to the public grid (AC side)   | 61        |
| Safety   | 61        |
| Connecting the inverter to the public grid (AC side)   | 61        |
| Connecting solar module strings to the inverter  | 64        |
| General comments regarding solar modules   | 64        |
| Safety   | 64        |
| PV generator - general information   | 65        |
| PV generator configuration 3 - 6 kW  | 65        |
| Connecting the solar module strings to the inverter  | 66        |
| Connecting the battery to the inverter   | 69        |
| Safety   | 69        |
| Connecting the battery on the DC side  | 69        |
| Connecting backup power - PV Point (OP)  | 73        |
| Safety   | 73        |
| Installation   | 73        |
| Connecting backup power - Full Backup  | 78        |
| Safety   | 78        |
| Cabling variants including backup power circuits with 1-pin separation e.g. Austria or Australia | 78        |
| All-pin separation cabling variant e.g. Germany, France, Spain                                   | 79        |

|  |            |
|--|------------|
| All-pin separation cabling variant, e.g. UK .....                            | 80         |
| All-pin separation cabling variant, e.g. Italy.....                          | 81         |
| Testing backup power mode.....   | 82         |
| Connecting the data communication cable .....                                | 83         |
| Modbus participants.....   | 83         |
| Routing data communication cables .....                                      | 84         |
| Connecting the battery communication cables.....                             | 86         |
| Terminating resistors.....   | 86         |
| Installing the WSD (wired shutdown).....                                     | 88         |
| Closing and commissioning the inverter.....                                  | 89         |
| Closing the inverter's connection area/housing cover, and commissioning..... | 89         |
| Starting the inverter for the first time .....                               | 89         |
| Button functions and LED status indicator .....                              | 90         |
| Installation with the app.....   | 91         |
| Installation using the web browser .....                                     | 92         |
| Switching off current supply and restarting the inverter .....               | 93         |
| De-energizing the inverter and switching it on again.....                    | 93         |
| <b>Settings - website of the inverter</b> .....                              | <b>95</b>  |
| User settings .....  | 97         |
| User login.....  | 97         |
| Selecting the language.....  | 97         |
| Device configuration .....   | 98         |
| Components.....  | 98         |
| Functions and I/Os .....   | 98         |
| Demand Response Modes (DRM) .....  | 100        |
| Inverter .....   | 100        |
| Energy management.....   | 103        |
| Energy management.....   | 103        |
| PV power reduction.....  | 103        |
| Load management.....   | 104        |
| System .....   | 105        |
| General .....  | 105        |
| Update.....  | 105        |
| Setup wizard.....  | 105        |
| Restoring the factory settings.....  | 105        |
| Event Log.....   | 105        |
| Information.....   | 105        |
| Licence manager.....   | 106        |
| Support.....   | 106        |
| Communication.....   | 108        |
| Network.....   | 108        |
| Modbus .....   | 109        |
| Fronius Solar API .....  | 110        |
| Safety and grid requirements .....   | 111        |
| Country setup.....   | 111        |
| Feed-in limitation .....   | 111        |
| Dynamic power regulation with several inverters.....                         | 112        |
| I/O power management.....  | 115        |
| Connection diagram - 4 relays .....  | 116        |
| I/O power management settings - 4 relays .....                               | 117        |
| Connection diagram - 3 relays .....  | 118        |
| I/O power management settings - 3 relays .....                               | 119        |
| Connection diagram - 2 relays .....  | 120        |
| I/O power management settings - 2 relays .....                               | 121        |
| Connection diagram - 1 relay .....   | 122        |
| I/O power management settings - 1 relay .....                                | 123        |
| Autotest(CEI 0-21).....  | 123        |
| <b>Options</b> .....   | <b>125</b> |
| Surge protective device (SPD).....   | 127        |

|                                  |     |
|----------------------------------|-----|
| General .....                    | 127 |
| Scope of supply .....            | 127 |
| De-energising the inverter.....  | 127 |
| Installation.....                | 128 |
| Commissioning the inverter ..... | 134 |

**Appendix 137**

|   |     |
|---|-----|
| Care, maintenance and disposal .....                                  | 139 |
| General .....   | 139 |
| Cleaning.....   | 139 |
| Maintenance.....  | 139 |
| Safety .....  | 139 |
| Operation in dusty environments.....                                  | 139 |
| Disposal .....  | 140 |
| Guarantee provisions.....   | 141 |
| Fronius manufacturer's warranty .....                                 | 141 |
| Components for automatic Full Backup backup power changeover.....     | 142 |
| Components for automatic Full Backup backup power changeover.....     | 142 |
| Status codes and remedy .....   | 144 |
| Status Codes.....   | 144 |
| Technical data .....  | 145 |
| Fronius Primo GEN24 3.0 / 3.0 Plus .....                              | 145 |
| Fronius Primo GEN24 3.6 / 3.6 Plus .....                              | 147 |
| Fronius Primo GEN24 4.0 / 4.0 Plus .....                              | 150 |
| Fronius Primo GEN24 4.6 / 4.6 Plus .....                              | 153 |
| Fronius Primo GEN24 5.0 / 5.0 Plus .....                              | 155 |
| Fronius Primo GEN24 6.0 / 6.0 Plus .....                              | 158 |
| Technical data of surge protective device DC SPD type 1+2 GEN24 ..... | 161 |
| Explanation of footnotes.....   | 161 |
| Integrated DC disconnecter .....                                      | 161 |

**Circuit diagrams 163**

|  |     |
|--|-----|
| Circuit Diagram - PV Point (OP) .....  | 165 |
| Circuit Diagram.....   | 165 |
| Fronius Primo GEN24 and BYD Battery-Box Premium HV.....  | 166 |
| Circuit Diagram.....   | 166 |
| Fronius Primo GEN24 with two BYD Battery-Box Premium HV connected in parallel.....                               | 167 |
| Circuit Diagram.....   | 167 |
| Fronius Primo GEN24 with three BYD Battery-Box Premium HV connected in parallel .....                            | 168 |
| Circuit Diagram.....   | 168 |
| Automatic switch to backup power 1-pin double separation - e.g. Austria.....                                     | 169 |
| Circuit Diagram.....   | 169 |
| Automatic switch to backup power 1-pin single separation - e.g. Australia.....                                   | 170 |
| Circuit Diagram.....   | 170 |
| Automatic switch to backup power 2-pin double separation - e.g. Germany.....                                     | 171 |
| Circuit Diagram.....   | 171 |
| Automatic switch to backup power 2-pin single separation - e.g. France, Spain.....                               | 172 |
| Circuit Diagram.....   | 172 |
| Automatic switch to backup power 2-pin double separation - e.g. UK .....   | 173 |
| Circuit Diagram.....   | 173 |
| Automatic switch to backup power 2-pin double separation with ext. grid and system protection - e.g. Italy ..... | 174 |
| Circuit Diagram.....   | 174 |
| Fronius Primo GEN24 with Enwitec Box.....  | 175 |
| Circuit Diagram.....   | 175 |
| Wiring diagram - surge protective device SPD.....  | 176 |
| Circuit Diagram.....   | 176 |

**Dimensions of the inverter 177**

|                                   |     |
|-----------------------------------|-----|
| Fronius Primo GEN24 3 - 6 kW..... | 179 |
| Fronius Primo GEN24 3 - 6 kW..... | 179 |

# Safety rules

## Explanation of safety notices

### **WARNING!**

**Indicates a potentially hazardous situation.**

- ▶ If not avoided, death or serious injury may result.

### **CAUTION!**

**Indicates a situation where damage could occur.**

- ▶ If not avoided, minor injury and/or damage to property may result.

### **NOTE!**

**Indicates a risk of flawed results and possible damage to the equipment.**

If you see any of the symbols depicted in the "Safety rules" chapter, special care is required.

## Safety

### **CAUTION!**

**Danger from crushing due to the incorrect handling of attachments and connection parts.**

Injuries to limbs may result.

- ▶ When lifting up, putting down and attaching the inverter, use the integrated grips.
- ▶ When fitting attachments, ensure that no limbs are located between the attachment and the inverter.
- ▶ Do not hold onto the individual poles on the terminals when locking and unlocking.

## General

The device has been manufactured in line with the state of the art and according to recognised safety standards. In the event of incorrect operation or misuse, there is a risk of

- Injury or death to the operator or a third party
- Damage to the device and other material assets belonging to the operating company

All personnel involved in commissioning, maintenance, and servicing of the device must:

- Be suitably qualified
- Have knowledge of and experience in dealing with electrical installations
- Have fully read and precisely followed these Operating Instructions

In addition to the Operating Instructions, all applicable local rules and regulations regarding accident prevention and environmental protection must also be followed.

All safety and danger notices on the device:

- Must be kept in a legible state
- Must not be damaged
- Must not be removed
- Must not be covered, pasted, or painted over

Only operate the device when all protection devices are fully functional. If the protection devices are not fully functional, there is a danger of

- Injury or death to the operator or a third party
- Damage to the device and other material assets belonging to the operating company

---

Any safety devices that are not fully functional must be repaired by an authorized specialist before the device is switched on.

---

Never bypass or disable protection devices.

---

For the location of the safety and danger notices on the device, refer to the chapter headed "Warning notices on the device" in the Operating Instructions for your device.

---

Faults that could compromise safety must be remedied before switching on the device.

---

### **Environmental conditions**

Operation or storage of the device outside the stipulated area will be deemed as not in accordance with the intended purpose. The manufacturer accepts no liability for any damage resulting from improper use.

---

### **Qualified personnel**

The servicing information contained in these operating instructions is intended only for the use of qualified service engineers. An electric shock can be fatal. Do not carry out any actions other than those described in the documentation. This also applies to qualified personnel.

---

All cables and leads must be secured, undamaged, insulated and adequately dimensioned. Loose connections, scorched, damaged or inadequately dimensioned cables and leads must be immediately repaired by authorised personnel.

---

Maintenance and repair work must only be carried out by an authorised specialist.

---

It is impossible to guarantee that bought-in parts are designed and manufactured to meet the demands made on them, or that they satisfy safety requirements. Use only original spare parts (also applies to standard parts).

---

Do not carry out any alterations, installations, or modifications to the device without first obtaining the manufacturer's permission.

---

Components that are not in perfect condition must be changed immediately.

---

### **Noise emission values**

The sound power level of the inverter is specified in the [Technical data](#).

---

The device is cooled as quietly as possible with the aid of an electronic temperature control system; this depends on the amount of converted power, the ambient temperature, the level of soiling of the device, etc.

---

It is not possible to provide a workplace-related emission value for this device because the actual sound pressure level is heavily influenced by the installation situation, the grid quality, the surrounding walls and the properties of the room in general.

---

### **EMC measures**

In certain cases, even though a device complies with the standard limit values for emissions, it may affect the application area for which it was designed (e.g. when there is sensitive equipment at the same location, or if the site where the device is installed is close to either radio or television receivers). If this is the case, then the operator is obliged to take appropriate action to rectify the situation.

---

**Backup power**

This system has backup power functions. This enables a replacement power supply to be established in the event of a failure in the public grid.

---

Where an automatic backup power supply is installed, a **backup power warning notice** (<https://www.fronius.com/en/search-page>, item number: 42,0409,0275) must be fitted on the electrical distributor.

---

Maintenance and installation work in the home network requires both disconnection on the utility side and deactivation of the replacement power mode by opening the integrated DC disconnect on the inverter.

---

Depending on the insolation conditions and the battery state of charge, the backup power supply is automatically deactivated and activated. This can cause the backup power supply to unexpectedly return from standby mode. Therefore, installation work can only be performed on the home network when the backup power supply is deactivated.

---

**Influencing factors on the total power in backup power mode:****Reactive power**

Electrical loads with a power factor not equal to 1 also require reactive power in addition to effective power. The reactive power also loads the inverter. Therefore, to correctly calculate the actual total power, it is not the rated power of the load that is relevant, but the current caused by effective and reactive power.

Devices with a high reactive power are mainly electric motors such as:

- Water pumps
- Circular saws
- Blowers and fans

**High starting current**

Electrical loads that need to accelerate a large mass usually require a high starting current. This can be up to 10 times higher than the nominal current. The maximum current of the inverter is available for the starting current. Loads with too high starting currents therefore cannot be started/operated, even though the nominal power of the inverter suggests that they can. When dimensioning the backup power circuit, the connected load power and any starting current must also be taken into account.

Devices with high starting currents are, for example:

- Devices with electric motors (e.g. lifting platform, circular saws, planing bench)
- Devices with large transmission ratio and flywheel mass
- Devices with compressors (e.g. compressed air compressors, air conditioning systems)

**IMPORTANT!**

Very high starting currents can cause short-term distortion or a drop in output voltage. The simultaneous operation of electronic devices in the same backup power supply system should be avoided.

**IMPORTANT!**

The inverter may only be operated within the limits of its technical capabilities. Operation outside of its technical capabilities can cause the inverter to shut down.

---

**Data protection**

The user is responsible for the safekeeping of any changes made to the factory settings. The manufacturer accepts no liability for any deleted personal settings.

---

**Copyright**

Copyright of these operating instructions remains with the manufacturer.

---



The text and illustrations are all technically correct at the time of printing. We reserve the right to make changes. The contents of the operating instructions shall not provide the basis for any claims whatsoever on the part of the purchaser. If you have any suggestions for improvement, or can point out any mistakes that you have found in the instructions, we will be most grateful for your comments.

---

**Protective earthing (PE)**

Connection of a point in the device, system or installation to earth to protect against electric shock in the event of a fault. When installing a safety class 1 inverter (see [Technical data](#)), the ground conductor connection is required.

When connecting the ground conductor, ensure that it is secured against accidental disconnection. All the points listed in the chapter [Connecting the inverter to the public grid \(AC side\)](#) on page [61](#) must be observed. It must be ensured that when using the strain relief devices, the ground conductor is the last to be disconnected in the event of a possible failure. When connecting the ground conductor, the minimum cross-section requirements specified by the respective national standards and guidelines must be observed.

# **General information**

# Fronius Primo GEN24

## Device concept

The inverter transforms the direct current generated by the PV modules into alternating current. This alternating current is fed into the public grid and synchronized with the mains voltage in use. Moreover, the solar energy can also be stored in a connected battery for later use.

The inverter is intended for use in grid-connected photovoltaic systems. The inverter has backup power functions and switches to backup power mode if it has been wired accordingly\*.

The inverter automatically monitors the public grid. Whenever conditions in the electric grid are inconsistent with standard conditions (for example, grid switch-off, interruption), the inverter will immediately stop producing power and interrupt the supply of power into the grid.

The grid is monitored by monitoring the voltage, frequency and islanding conditions.

After installation and commissioning, the inverter's operation is fully automatic; the inverter draws the maximum possible power from the PV modules. Depending on the operating point, this power is used in the home, stored in a battery\* or fed into the grid.

As soon as the energy provided by the PV modules is no longer sufficient, the power from the battery is fed into the home. Depending on the setting, power may also be obtained from the public grid in order to charge the battery\*.

When its temperature gets too high, the inverter automatically reduces the output or charging power, or switches off completely, in order to protect itself. Reasons for the temperature being too high include a high ambient temperature or insufficient heat dissipation (for example, inadequate heat dissipation when installed in switch cabinets).

\* Depending on the device variant, suitable battery, appropriate wiring, settings and local standards and guidelines.

## Function overview

| Function                             | Primo GEN24              | Primo GEN24 Plus |
|--------------------------------------|--------------------------|------------------|
| Backup power variant - PV Point (OP) | ✓                        | ✓                |
| Battery connection*                  | Available as an option** | ✓                |
| Backup power variant - Full Backup   | Available as an option** | ✓                |

\* For suitable batteries, see chapter [Suitable battery](#).

\*\* The functions are optionally available via Fronius UP (see chapter [Fronius UP](#)).

## Fronius UP

With Fronius UP\*, the inverter can be expanded by the authorised specialist to include optionally available functions (see chapter [Function overview](#)).

\* The availability of Fronius UP varies from country to country. For more information on Fronius UP and availability, see [Installation guide: Fronius GEN24 & GEN24 Plus](#).

## Scope of supply

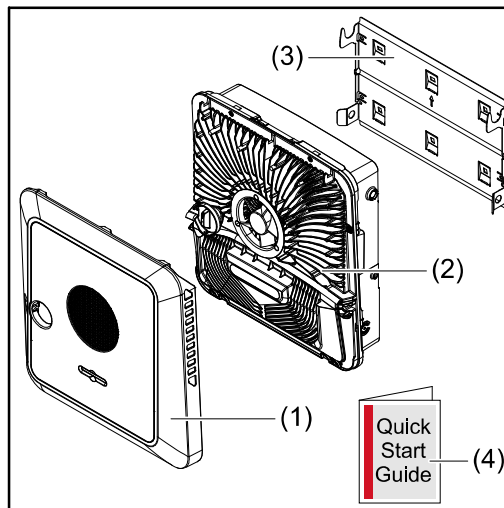

- (1) Housing cover
- (2) Inverter
- (3) Mounting bracket (illustration)
- (4) Quick Start guide

## Intended use

The inverter is designed to convert direct current from PV modules into alternating current and feed this power into the public grid. A backup power mode\* is possible provided that appropriate cabling has been installed.

The following are considered improper use:

- Utilisation for any other purpose, or in any other manner
- Alterations to the inverter are not permitted unless expressly recommended by Fronius
- Installation of components is not permitted unless expressly recommended or sold by Fronius

The manufacturer is not responsible for any damage resulting from improper use. All warranty claims are considered void in such cases.

Intended use also means:

- Carefully reading and obeying all the instructions, as well as safety and danger notices in the Operating Instructions
- Installation in accordance with chapter "**Installation**" from page **45**

When configuring the photovoltaic system, make sure that all components of the photovoltaic system are operating exclusively within their permissible operating range.

Observe all measures recommended by the PV module manufacturer to permanently maintain the PV module properties.

Observe the grid operator's regulations for energy fed into the grid and connection methods.

The Fronius GEN24 inverter is a grid-connected inverter with a backup power function – it is not a stand-alone inverter. The following restrictions must therefore be observed in backup power mode:

- Backup power mode may be in operation for at least 2000 hours
- Backup power mode may be in operation for more than 2000 operating hours if 20% of the duration of the inverter's grid power feed operation is not exceeded at the relevant time.

\* Depending on the device variant, suitable battery, appropriate wiring, settings and local standards and guidelines.

## Thermal concept

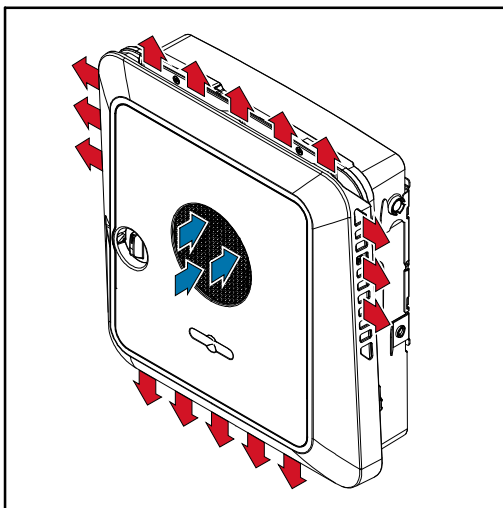

Ambient air is drawn in by the fan on the front side and blown out at the device sides. The even heat dissipation allows several inverters to be installed next to each other.

### NOTE!

#### Risk due to insufficient cooling of the inverter.

This may result in a loss of power in the inverter.

- ▶ Do not block the fan (for example, with objects that protrude through the touch guard).
- ▶ Do not cover the ventilation slots, even partially.
- ▶ Make sure that the ambient air can always flow through the inverter's ventilation slots unimpeded.

## Fronius Solar.web

With Fronius Solar.web or Fronius Solar.web Premium, the PV system can be easily monitored and analysed by the system owner and installer. If configured accordingly, the inverter transmits data such as power, yields, load, and energy balance to Fronius Solar.web. For more information see [Solar.web - monitoring & analysis](#).

Configuration is carried out via the setup wizard, see chapter [Installation with the app](#) on page [91](#) or [Installation using the web browser](#) on page [92](#).

#### Prerequisites for configuration:

- Internet connection (download: min. 512 kBit/s, upload: min. 256 kBit/s)\*.
- User account on [solarweb.com](#).
- Completed configuration via the setup wizard.

\* The information given does not constitute an absolute guarantee of faultless function. High error rates in the transmission, reception fluctuations or transmission drop-outs can have a negative effect on the data transfer. Fronius recommends testing the Internet connection on site according to the minimum requirements.

# The various operating modes

## Operating modes – Explanation of symbols

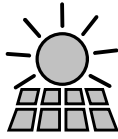

### PV module

generates direct current

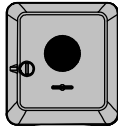

### Fronius GEN24 inverter

converts direct current into alternating current and charges the battery (battery charging is only possible with Fronius GEN24 Plus inverters). The integrated system monitoring enables the inverter to be integrated into a network by means of WLAN.



### Additional inverter in the system

converts the direct current into alternating current. However, it cannot charge a battery, and is not available in backup power mode.



### Battery

is coupled to the inverter on the direct current side, and stores electrical energy.

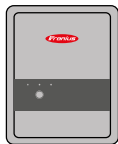

### Fronius Ohmpilot

for using excess energy to heat water.



### Primary meter

records the system's load curve and provides measurement data for energy profiling in Fronius Solar.web. The primary meter also controls the dynamic feed-in control.



### Secondary meter

records the load curve of individual loads (e.g. washing machine, lamps, TV, heat pump, etc.) in the consumption branch and provides measurement data for energy profiling in Fronius Solar.web.

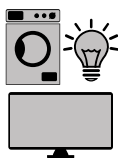

### Loads in the PV system

are the loads connected in the system.



### Additional loads and generators in the system

are connected to the system by means of a utility meter.



### PV Point

is a non-uninterruptible single-phase backup power circuit which supplies electrical devices with up to 3 kW if sufficient power is available from the PV modules or the battery.



### Full Backup

the inverter is prepared for backup power mode. The backup power mode must be implemented in the switch cabinet by the electrician performing the installation. The PV system operates in a stand-alone manner in backup power mode.

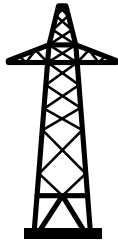

### Grid

supplies the loads in the system if insufficient power is being generated by the PV modules or supplied by the battery.

### Operating mode – Inverter with battery

In order to be able to obtain the highest rate of self-consumption with your PV system, a battery can be used to store excess energy. The battery is coupled to the inverter on the direct current side. Multiple current conversion is therefore not required, and the efficiency is increased.

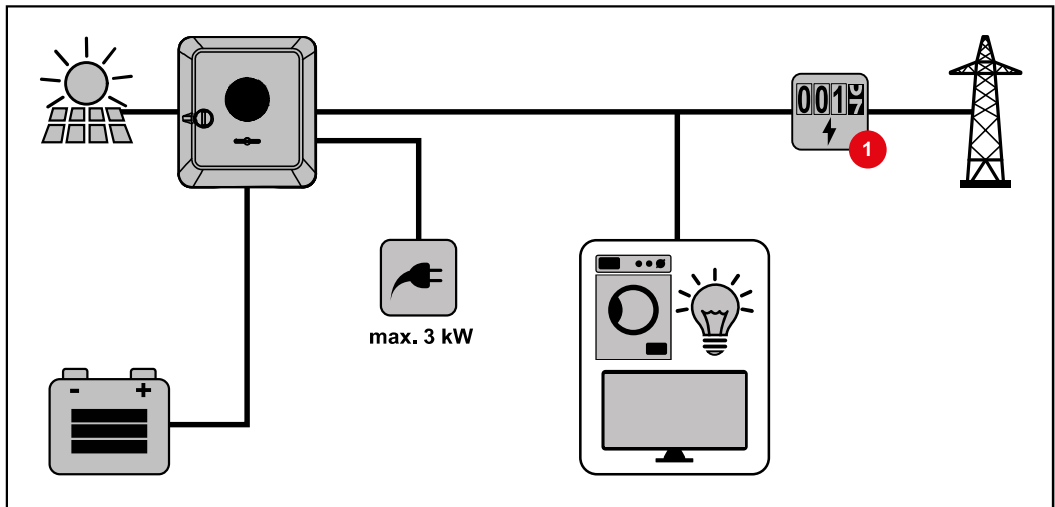

### Operating mode – Inverter with battery and several Smart Meters

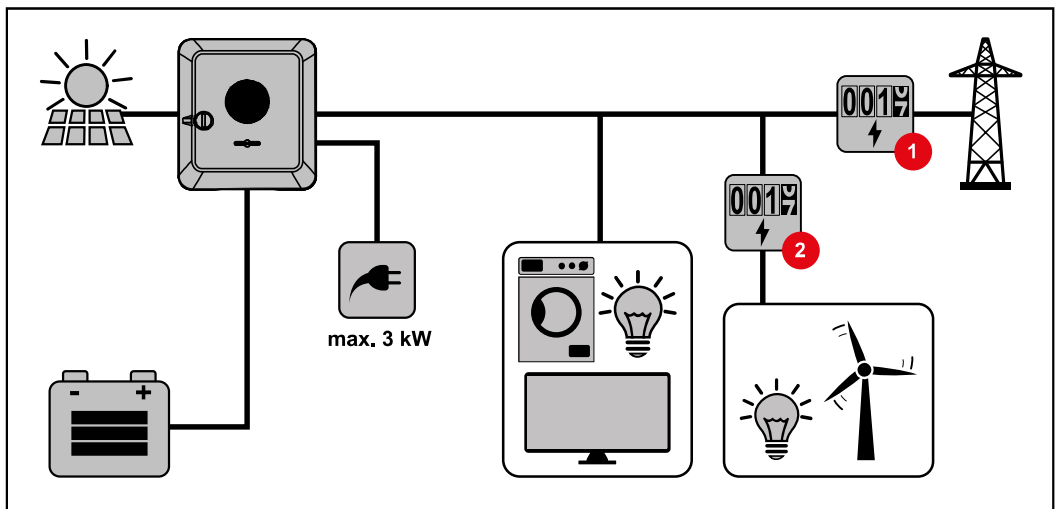

**Operating mode - inverter with battery, AC-coupled to another inverter**

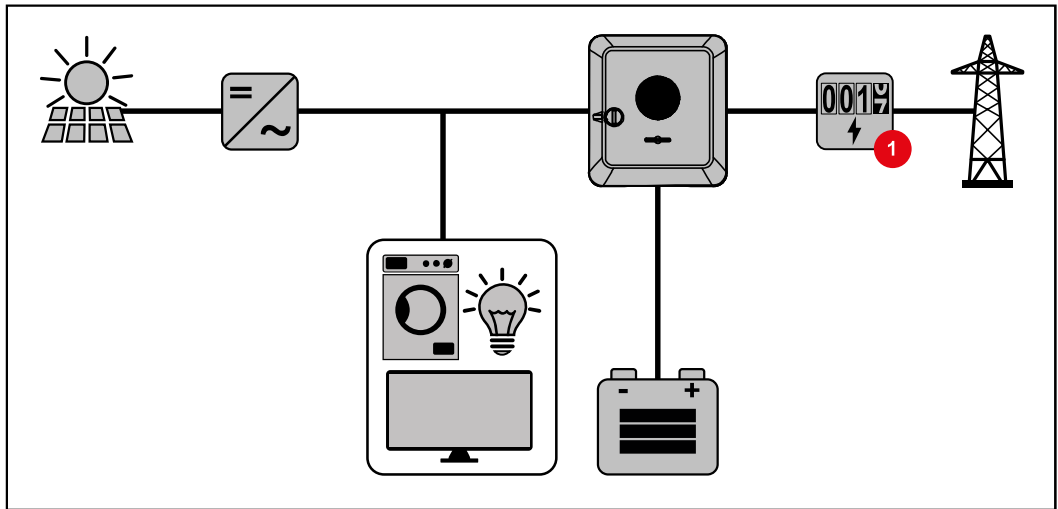

**Operating mode – Inverter with battery and backup power function**

**IMPORTANT!**

In backup power mode, an increased nominal frequency is used in order to prevent undesired parallel operation with other power generators.

In the fully equipped hybrid PV system, the inverter can:

- Supply loads in the house
- Store excess energy in the battery and/or feed it into the grid
- Supply connected loads in the event of a power failure

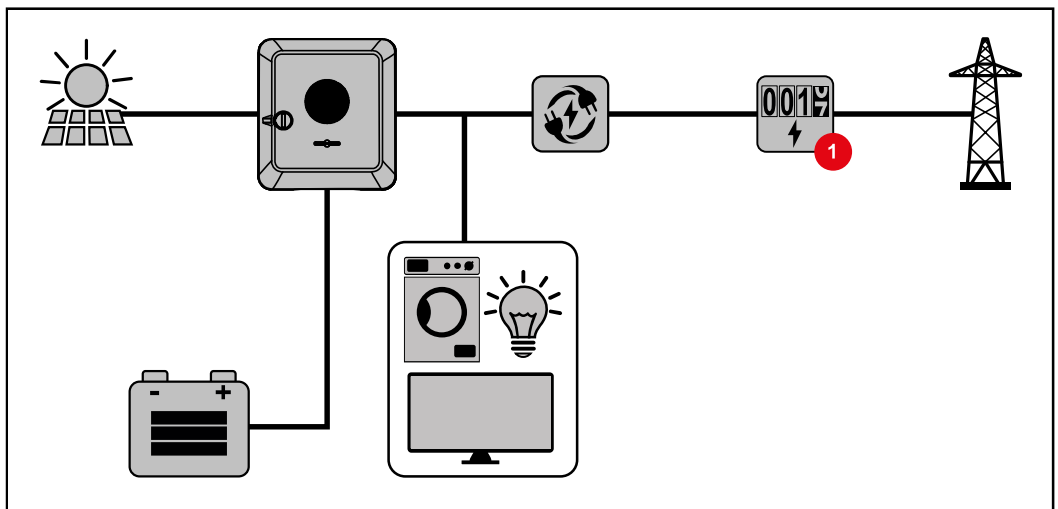

**Operating mode – Inverter with battery, Ohmpilot and backup power function**

**IMPORTANT!**

In the fully equipped hybrid PV system with a Fronius Ohmpilot, the Ohmpilot cannot be operated in the event of a power failure for regulatory reasons. It is therefore sensible to install the Ohmpilot outside of the backup power branch.



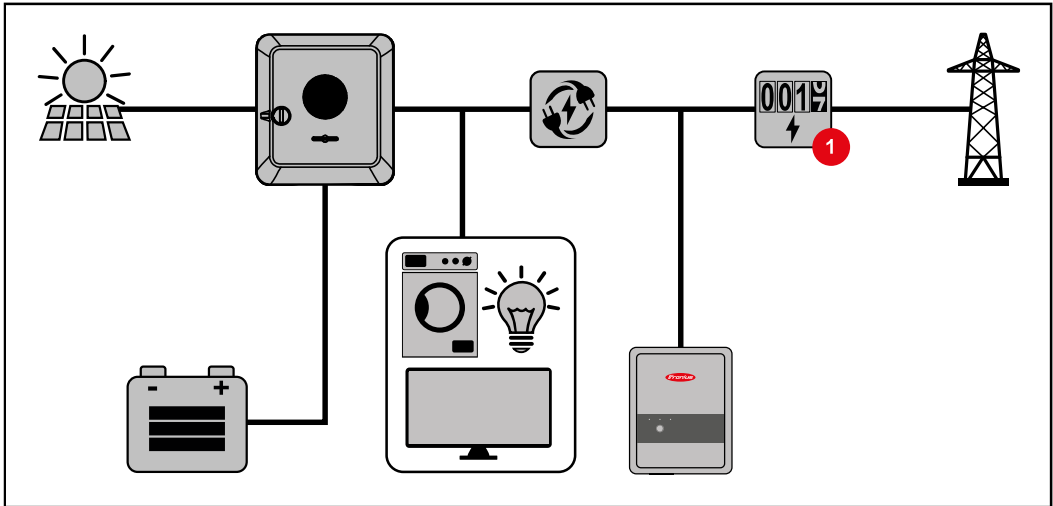

**Operating mode – Inverter with battery, further inverter and backup power function**

In the hybrid photovoltaic system, batteries must only be connected to one inverter with battery support. Batteries cannot be split between multiple inverters with battery support. However, depending on the battery manufacturer, several batteries can be combined on one inverter.

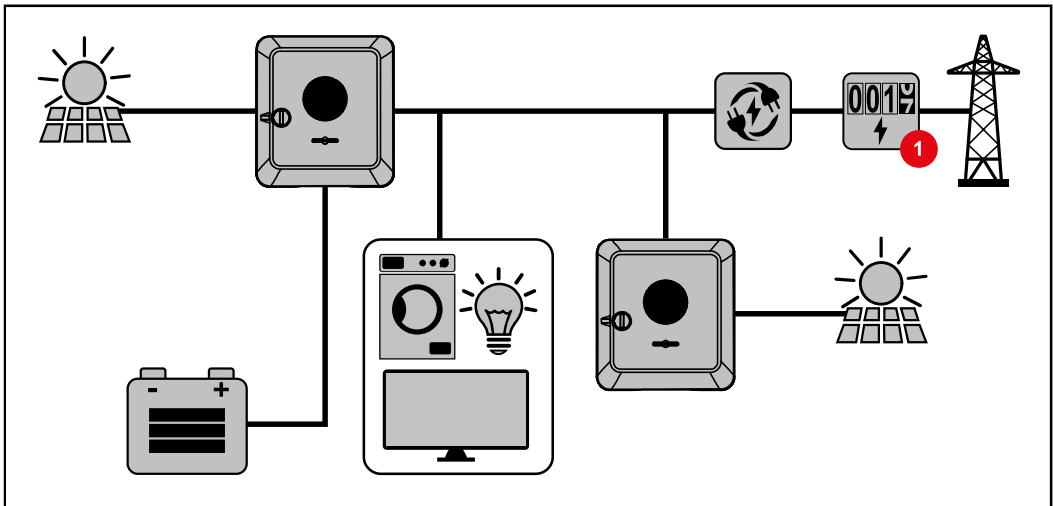

**Energy flow direction of the inverter**

In the case of hybrid inverters, there are four different energy flow directions:

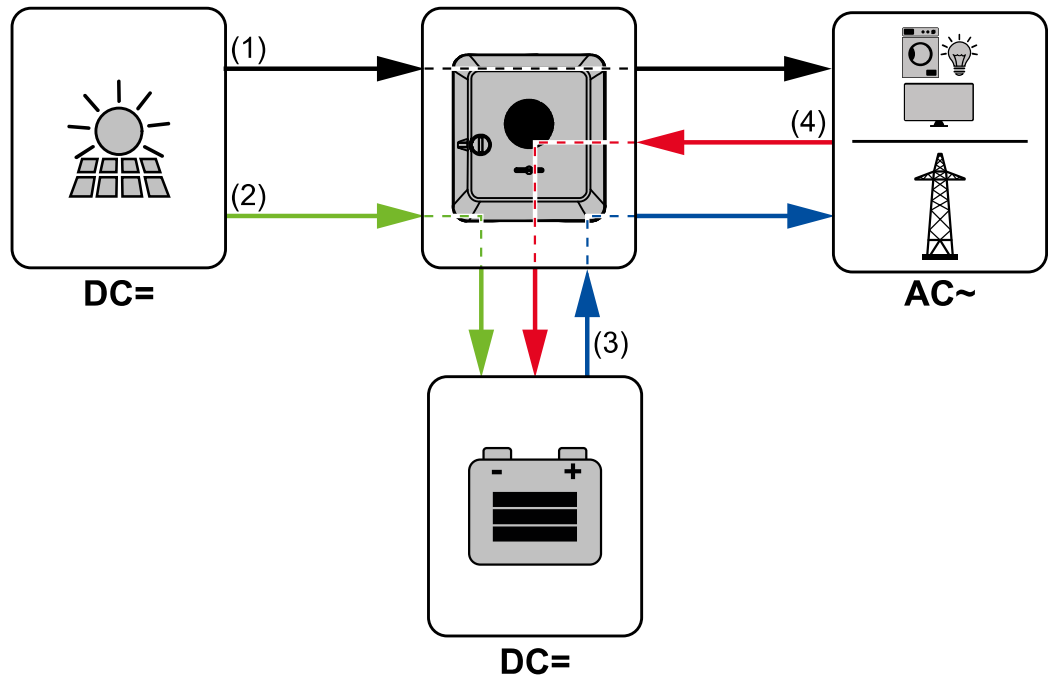

- (1) Solar module – inverter – load/grid
- (2) Solar module – inverter – battery\*
- (3) Battery – inverter – load/grid\*
- (4) Grid – inverter – battery\*

\* depending on the settings and local standards and regulations.

**Operating states  
(only for systems  
with a battery)**

Battery systems distinguish different operating states. In this case, the relevant current operating state is displayed on the website of the inverter or in Solar.web.

| Operating state                     | Description   |
|-------------------------------------|---|
| Normal operation                    | Energy is stored or drawn, as required.   |
| Min. state of charge (SOC) achieved | Battery has reached the minimum SOC set or specified by the manufacturer. The battery cannot be discharged any further.   |
| Energy saving mode (standby)        | The system has been put into energy saving mode. Energy saving mode is automatically ended as soon as sufficient excess energy is available again.                            |
| Start                               | The storage system starts from energy saving mode (standby).  |
| Forced re-charging                  | The inverter re-charges the battery, in order to maintain the set minimum SOC (state of charge) or the SOC specified by the manufacturer (protection against deep discharge). |
| Deactivated                         | The battery is not active. It has either been deactivated/switched off, or an error means that no communication with the battery is possible.                                 |

# Energy saving mode

## General

Energy saving mode (standby mode) is used to reduce the self-consumption of the system. Both the inverter and the battery automatically switch to energy saving mode under certain conditions.

The inverter switches to energy saving mode if the battery is flat and no PV power is available. Only the inverter's communication with the Fronius Smart Meter and Fronius Solar.web is maintained.

## Switch-off conditions

If all the switch-off conditions are met, the battery switches into energy saving mode within ten minutes. This time delay ensures that the inverter can at least be restarted.



≤ min. SoC

The battery state of charge is less than or equal to the input minimum state of charge.



< 100 W

The current charging or discharging power of the battery is less than 100 W.



< 50 W

Less than 50 W is available for charging the battery. The power of feeding into the public grid is at least 50 W less than the power currently required in the home network.

The inverter automatically switches into energy saving mode, following the battery.

## Switch-on conditions

If one of the following conditions is met for at least 30 seconds, energy saving mode is ended:

- Energy saving mode is no longer permissible owing to a changed setting on the user interface of the inverter.
- If dynamic power reduction of 0 is set, or if the system is operating in backup power mode, the power of feeding into the public grid is always less than the required power in the home network.  
There is a separate condition for this case (dynamic power reduction < 300 W or active backup power mode): if the PV power is above a specified threshold, energy saving mode is ended.
- Battery charging from the public grid is requested via the website.
- The battery is being recharged in order to restore the minimum state of charge or perform calibration.

## Special case

If the inverter does not operate for 12 minutes (e.g. fault), or there is an interruption in the electrical connection between the inverter and the battery and there is no backup power mode, the battery switches to energy-saving mode in any case. This reduces self discharge of the battery.

**Indication of energy saving mode**

During energy saving mode:

- Operating LED for the inverter lights up orange (see [Button functions and LED status indicator](#) on page 90).
- The website of the inverter can be reached.
- All the available data is saved and transmitted to Solar.web.
- The real-time data can be seen on Solar.web.

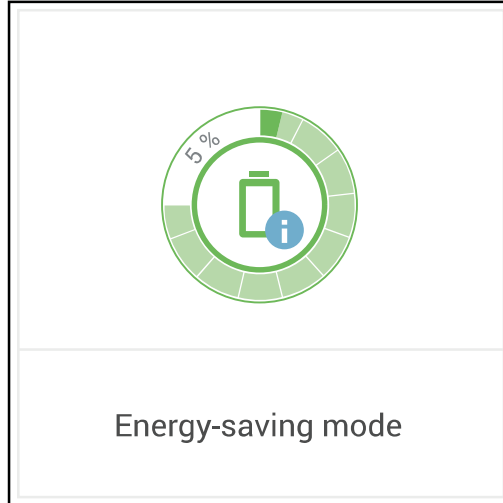

Energy saving mode is shown on the website of the inverter and in Solar.web by an "i" beside the battery symbol in the system overview.

# Suitable battery

## BYD Battery-Box Premium

Fronius explicitly points out that the third-party batteries are not Fronius products. Fronius is not the manufacturer, distributor or retailer of these batteries. Fronius accepts no liability and offers no service or guarantees for these batteries.

Obsolete firmware/software states may lead to incompatibilities between the inverter and the battery. In this case, the following steps are to be performed:

- Update battery software – see the battery documentation.
- Update inverter firmware – see [Update](#) on page 105.

Before installation and commissioning, read this document and the Installation Instructions for the external battery.

All the documents relating to the inverter can be found at the following address:

<https://www.fronius.com/en/solar-energy/installers-partners/service-support/tech-support>

The documentation for the BYD Battery-Box Premium is enclosed with the third-party battery or can be obtained from the battery manufacturer and its service partners.

| BYD Battery-Box Premium HVS        | 5.1 | 7.7 | 10.2 | 12.8 |
|------------------------------------|-----|-----|------|------|
| Fronius Primo GEN24 3.0 - 6.0*     | ✓   | ✓   | ✗    | ✗    |
| Fronius Primo GEN24 3.0 - 6.0 Plus | ✓   | ✓   | ✗    | ✗    |
| Number of battery modules          | 2   | 3   | 4    | 5    |
| Battery parallel operation**       | ✓   | ✓   | ✗    | ✗    |

| BYD Battery-Box Premium HVM        | 8.3 | 11.0 | 13.8 | 16.6 | 19.3 | 22.1 |
|------------------------------------|-----|------|------|------|------|------|
| Fronius Primo GEN24 3.0 - 6.0*     | ✗   | ✓    | ✓    | ✓    | ✓    | ✗    |
| Fronius Primo GEN24 3.0 - 6.0 Plus | ✗   | ✓    | ✓    | ✓    | ✓    | ✗    |
| Number of battery modules          | 3   | 4    | 5    | 6    | 7    | 8    |
| Battery parallel operation**       | ✗   | ✓    | ✓    | ✓    | ✓    | ✗    |

\* Battery support optionally available.

\*\* Max. 3 batteries with the same capacity can be combined.

**IMPORTANT!** To ensure reliable operation with a BYD Battery-Box Premium, the following switch-on sequence for the system must always be observed.

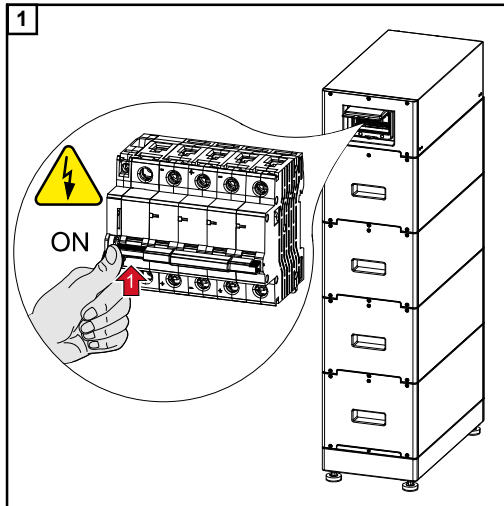

Switch on the battery.

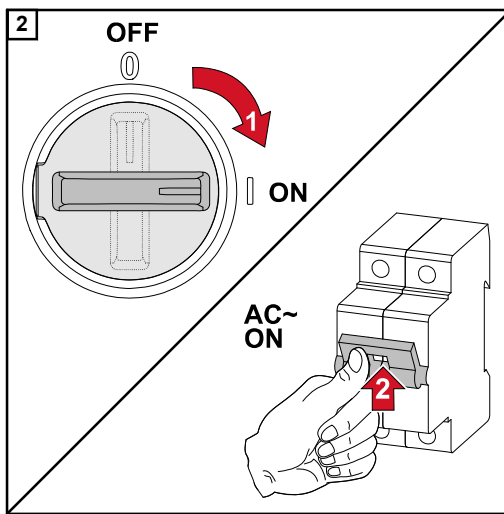

Set the DC disconnect to the "On" switch position. Switch on the automatic circuit breaker.

# Protection of people and equipment

---

## Central grid and system protection

The inverter offers the option to use the integrated AC relays as coupling switches in conjunction with a central grid and system protection unit (in accordance with VDE-AR-N 4105:2018:11 §6.4.1). For this purpose, the central trigger device (switch) must be integrated into the WSD chain as described in the chapter "WSD (Wired Shut Down)".

---

## WSD (wired shutdown)

The wired shutdown (WSD) interrupts the inverter feeding energy into the grid if the trigger device (switch) has been activated.

If an inverter (secondary device) fails, it is bypassed and the other inverters continue operating. If a second inverter (secondary device) or the inverter (primary device) fails, the operation of the entire WSD chain is interrupted.

For installation, see [Installing the WSD \(wired shutdown\)](#) on page 88.

---

## RCMU

The inverter is equipped with a universal current-sensitive residual current monitoring unit (RCMU = Residual Current Monitoring Unit) in accordance with IEC 62109-2. This device monitors residual currents from the PV module to the AC output of the inverter and disconnects the inverter from the grid in the event of unauthorised residual current.

---

## Surge protective device

The inverter is equipped with an integrated surge protective device on the DC and AC side in accordance with IEC 62109-2. The surge protective device protects the system against damage in the event of an overvoltage.

# Control elements and connections

## Connection area

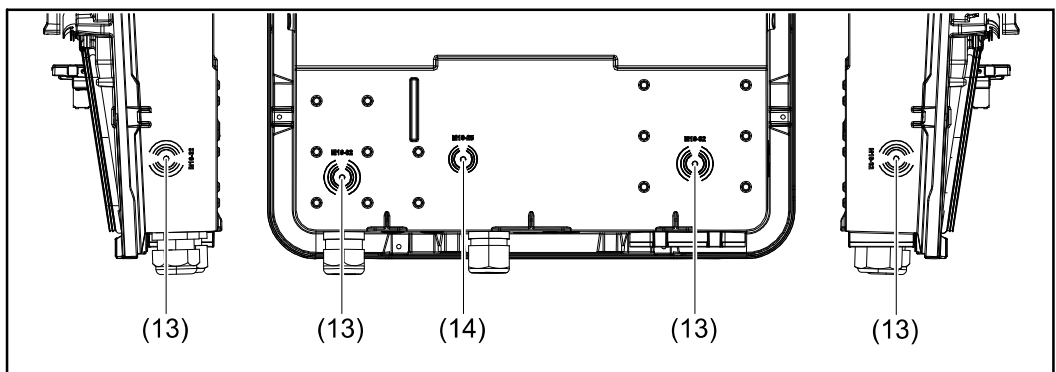
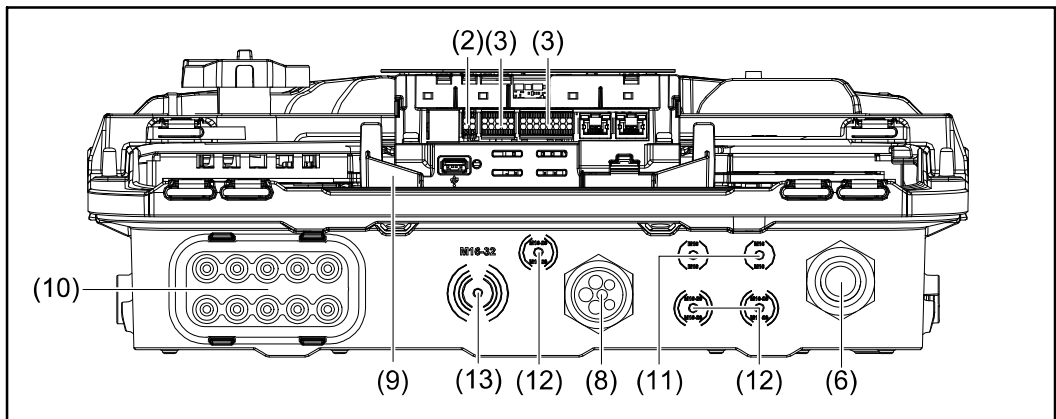
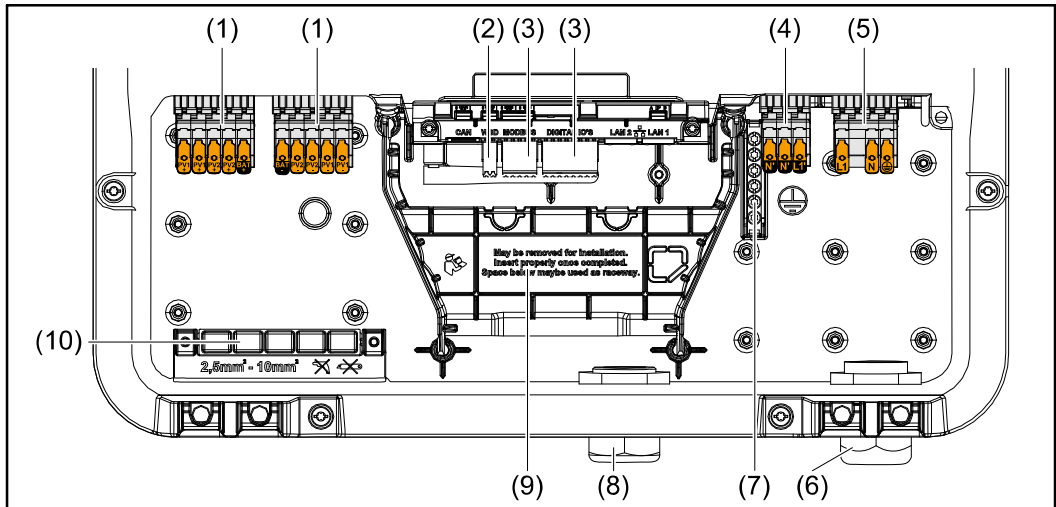

- (1) 2 x 5-pin DC push-in terminal
- (2) Push-in WSD (wired shutdown) terminal
- (3) Push-in terminals in the data communication area (Modbus, digital inputs and outputs)
- (4) 3-pin push-in terminal for PV Point (OP)
- (5) 3-pin AC push-in terminal
- (6) Cable gland/strain-relief device AC
- (7) 6-pin ground electrode terminal
- (8) Cable gland/strain-relief device in the data communication area



- (9) Connection area divider
- (10) 10 x DC cable glands
- (11) Optional cable gland (M16)
- (12) Optional cable gland (M16 - M20)
- (13) Optional cable gland (M16 - M32)
- (14) Optional cable gland (M16 - M25)

### Connection area divider

The connection area divider separates the high-voltage conductors (DC and AC) from the signal lines. To make it easier to reach the connection area, the divider can be removed for the connection work, and must be re-inserted.

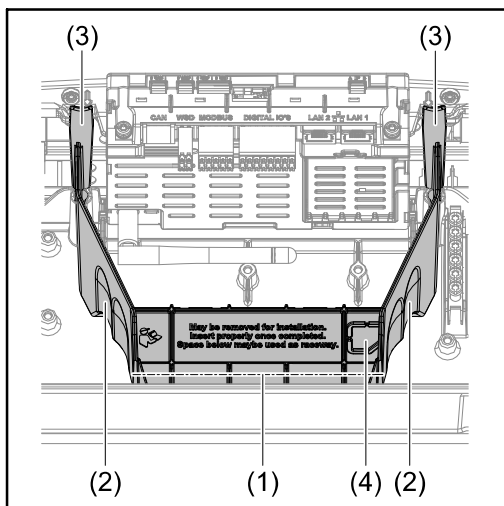

- (1) Integrated cable duct
- (2) Recesses for removing the connection area divider
- (3) Snap tabs for locking/unlocking
- (4) Defined breaking point for the Dat-com connection

The integrated cable duct (1) allows for the lines to be laid from one area of the inverter to the other. As a result, multiple inverters can be easily installed next to each other.

### Ground electrode terminal

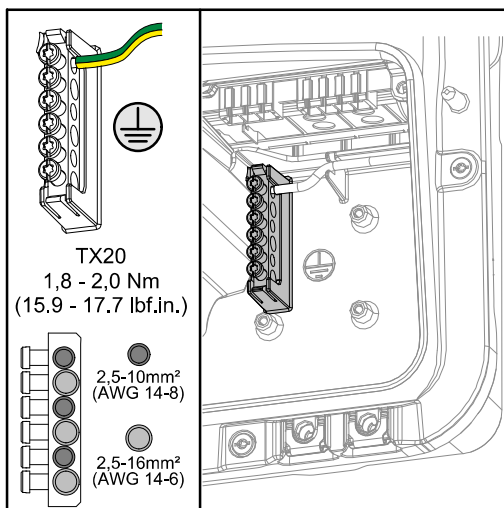

The ground electrode terminal  $\oplus$  Allows additional components to be earthed, such as:

- AC cable
- Module mounting system
- Ground rod

## DC disconnect

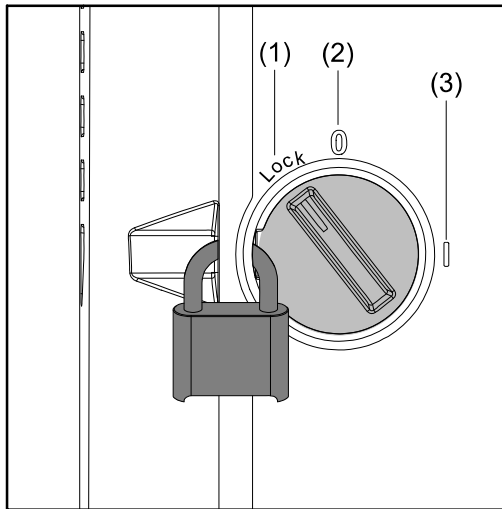

The DC disconnect has three switch settings:

- (1) Locked/off (turned to the left)
- (2) Off
- (3) On

### IMPORTANT!

In switch settings (1) and (3), a conventional padlock can be used to secure the inverter against being switched on/off.

- The national guidelines must be complied with in this respect.

## Data communication area

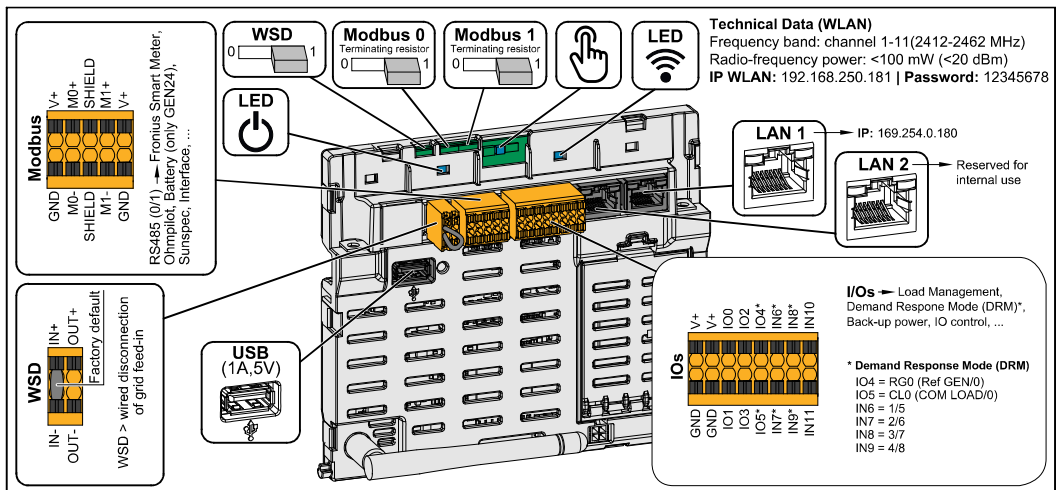

Push-in terminal for the installation of Modbus 0, Modbus 1, 12 V and GND (ground).

## Modbus terminal



The data connection to the connected components is established via the Modbus terminal. **The inputs M0 and M1 can be selected for this purpose.** Max. 4 Modbus participants per input, see chapter **Modbus participants** on page 83.

## WSD (wired shutdown) switch

Defines the inverter as a WSD primary device or WSD secondary device.

**Position 1:** WSD primary device

**Position 0:** WSD secondary device

|   |   |
|---|---|
| <b>Modbus 0 (MB0) switch</b>  | Switches the terminating resistor for Modbus 0 (MB0) on/off.<br><br><b>Position 1:</b> Terminating resistor on (factory setting)<br><b>Position 0:</b> Terminating resistor off   |
| <b>Modbus 1 (MB1) switch</b>  | Switches the terminating resistor for Modbus 1 (MB1) on/off.<br><br><b>Position 1:</b> Terminating resistor on (factory setting)<br><b>Position 0:</b> Terminating resistor off   |
|  <b>Optical sensor</b>       | To operate the inverter. See chapter <a href="#">Button functions and LED status indicator</a> on page 90.  |
|  <b>Communication LED</b>    | Indicates the inverter connection status.   |
|  <b>Operating status LED</b> | Indicates the inverter operating status.  |
| <b>LAN 1</b>  | Ethernet connection for data communication (e.g. WLAN router, home network or for commissioning with a laptop see chapter <a href="#">Installation using the web browser</a> on page 92).   |
| <b>LAN 2</b>  | Ethernet port for internal use only (support).  |
| <b>WSD terminal</b>   | Push-in terminal for the WSD installation. See chapter " <a href="#">WSD (wired shut-down)</a> " on page 25.  |
| <b>USB</b>  | Power supply max. 1 A at 5 V. Software updates and data recording via USB is not possible.  |
| <b>IOs terminal</b>   | Push-in terminal for digital inputs/ outputs. See chapter <a href="#">Permitted cables for the data communication area</a> on page 58.<br>The designations (RG0, CL0, 1/5, 2/6, 3/7, 4/8) on the terminal refer to the Demand Response Mode function, see chapter <a href="#">Functions and IOs</a> on page 98. |

### Internal schematic connection diagram of the IOs

On the V+/GND pin, it is possible to feed in a voltage of around 12.5 - 24 V (+ max. 20%) with an external power supply. The outputs IO 0 - 5 can then be operated with the external voltage. A maximum of 1 A can be drawn per output, with a maximum of 3 A allowed in total. The fuse protection must be located externally.

**⚠ CAUTION!**

**Risk of polarity reversal at the terminals due to improper connection of external power supplies.**

This may result in severe damage to the inverter.

- ▶ Check the polarity of the external power supply with a suitable measuring device before connecting it.
- ▶ Connect the cables to the V+/GND outputs with the correct polarity.

**IMPORTANT!**

If the total output (6 W) is exceeded, the inverter switches off the entire external power supply.

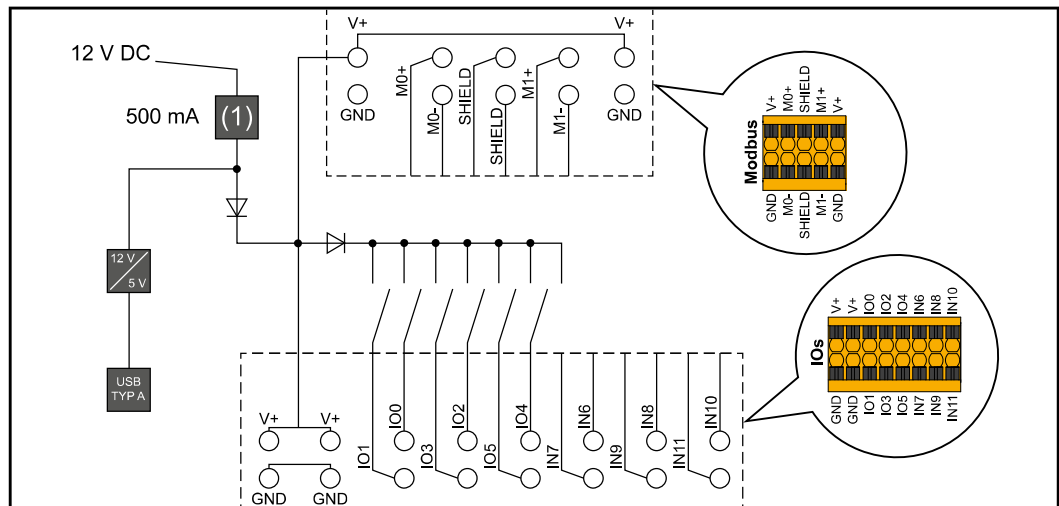

(1) Power limitation

# **Backup power variant - PV Point (OP)**

## PV Point (OP)

### IMPORTANT!

If several backup power variants are available, please note that only one backup power variant may be installed and configured.

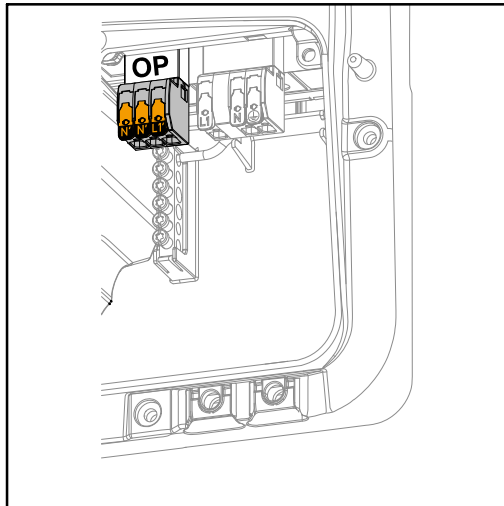

With the PV Point, in the event of a failure of the public grid, electrical devices can be connected to the Opportunity Power (OP) terminal and supplied with a maximum power of 3 kW, if enough power is available from the PV modules or an optional battery. In grid-connected operation, the OP terminal is not supplied with voltage, therefore the connected loads will not be supplied with power in this operating mode.

### IMPORTANT!

A relay-based network switching setup is not possible.

## Explanation - PV Point (OP)

The inverter can provide 120 to 240 V at the PV Point. A corresponding configuration must be set up during commissioning.

At 120 to 240 V output voltage, a maximum of 13 A AC continuous current is available.

### For example:

120 V = max. 1.5 kW

230 V = max. 3 kW

In backup power mode, some electrical appliances cannot function properly as starting currents are too high (for example, fridges and freezers). It is recommended to switch off non-essential loads during backup power mode. Overload capacity of 35% is possible for a duration of 5 seconds, depending on the capacity of the solar modules and/or the battery at that moment in time.

There is a brief interruption when switching from grid-connected mode to backup power mode. For this reason, the backup power function cannot be used as an uninterruptible power supply, for example for computers.

If no energy from the battery or the solar modules is available in backup power mode, backup power mode ends automatically. If sufficient energy becomes available from the solar modules once again, backup power mode starts again automatically.

In the event of excessive consumption, backup power mode is stopped and the "backup power overload" status code is displayed on the inverter's LED status indicator. The maximum power in backup power mode according to the technical data must be observed.

# **Backup power variant - Full Backup**

## Prerequisites for backup power mode

### IMPORTANT!

If several backup power variants are available, please note that only one backup power variant may be installed and configured.

In order to use the inverter's backup power function, the following prerequisites must be fulfilled:

- The inverter must support the backup power variant – Full Backup (see chapter [Function overview](#) on page 13).
- A battery suitable for backup power use must be installed and configured.
- Correct cabling of the backup power system in the electrical installation or usage of a switch box from Enwitec (see chapter [Components for automatic Full Backup backup power changeover](#) on page 142 or [Circuit diagrams](#) on page 163).
- Mount and configure the Fronius Smart Meter at the feed-in point.
- Attach a [warning notice for the backup power supply](https://www.fronius.com/en/search-page) (https://www.fronius.com/en/search-page, item number: 42,0409,0275) on the electrical distributor.
- Apply the necessary settings in the "Devices and system components" → "Functions and pins" → "Backup power" menu area and activate backup power.
- Follow the [backup power checklist](https://www.fronius.com/en/search-page) (https://www.fronius.com/en/search-page, item number: 42,0426,0365) step by step and confirm.

## Transitioning from feeding energy into the grid to backup power mode

1. The public grid is monitored by the inverter's internal grid and system protection unit and by the Fronius Smart Meter connected to it.
2. **The public grid fails or specific grid parameters are dropped below or exceeded.**
3. The inverter carries out the measures necessary according to the country standard and then switches off.
4. The inverter starts backup power mode after a checking period.
5. All loads in the household that are in the backup power circuit are supplied by the battery and the PV modules. The remaining loads are not supplied with power and are safely isolated.

## Transitioning from backup power mode to feeding energy into the grid

1. The inverter is operating in backup power mode.
2. **The public grid is functioning correctly again.**
3. The Fronius Smart Meter monitors the grid parameters on the public grid and passes this information to the inverter.
4. The stability of the returned public grid is determined by checking the measured values of the Fronius Smart Meter.
5. The inverter ends backup power mode.
6. All circuits are reconnected to the public grid and are supplied by the grid.
7. The inverter can start feeding energy into the grid again after performing the grid checks required by the relevant standard.

## Backup power and energy saving mode

Under the following conditions, the battery and the inverter are switched to energy saving mode after a waiting time of 8 - 12 minutes and backup power mode is ended:

- The battery is discharged to the minimum state of charge and no energy is coming from the PV modules.
- The inverter is set to energy saving mode (standby mode).



If the battery and inverter are in energy saving mode, the system is reactivated by the following:

- Enough energy is available from the solar modules.
- The public grid is functioning again.
- The battery is switched off and on.

# Cabling variants including backup power circuits with 1-pin separation e.g. Austria or Australia

## Functions

- Measuring and transferring the required parameters for energy management and Solar.web by the Fronius Smart Meter.
- Disconnecting from the public grid to enable operation in backup power mode if the grid parameters are outside the country-specific standards.
- Reconnecting to the public grid when the grid parameters are within the limits specified by the country-specific standards.
- Option of having a separate backup power circuit or several backup power circuits that are supplied even during failure of the public grid. The total load of the backup power circuits must not exceed the nominal output of the inverter. Furthermore, the performance of the connected battery must also be considered.

## Transitioning from feeding energy into the grid to backup power mode

1. The public grid is monitored by the inverter's internal grid and system protection unit and by the Fronius Smart Meter connected to it.
2. **Failure of the public grid.**
3. The inverter carries out the necessary measures according to the country standard and then switches off. Contactors K1 and K2 (K2 - optional in Australia) drop out. This disconnects the backup power circuits and the inverter from the rest of the home network and from the public grid, as the main contacts of the contactors K1 and K2 1-pin open. The inverter activates relay K3, which interrupts the supply to contactors K1 and K2. This prevents unintentional activation of contactors K1 and K2 and thus a grid connection when voltage is restored in the grid. The NC auxiliary contacts of contactors K1 and K2 send feedback to the inverter that the contactors are open (a condition for starting backup power mode).
4. The NO contact of relay K3 gives additional feedback to the inverter on whether the locking was successfully performed by relay K3.
5. The inverter decides based on the contactors' feedback as well as the measurements on the inverter terminals and the Smart Meter that backup power mode can be started.
6. After all the required activation tests have been carried out, the inverter starts backup power mode.
7. All loads in the backup power circuits are supplied with power. The remaining loads are not supplied with power and are safely isolated.

## Transitioning from backup power mode to feeding energy into the grid

1. The inverter is operating in backup power mode. The contactors K1 and K2 to the public grid are open.
2. **Public grid available again.**
3. The Fronius Smart Meter monitors the grid parameters on the public grid and passes this information to the inverter.
4. The stability of the returned public grid is determined by checking the measured values of the Fronius Smart Meter.
5. The inverter ends backup power mode and disconnects the outputs.
6. The inverter deactivates K3. The contactors K1 and K2 are reactivated.
7. All circuits are reconnected to the public grid and are supplied by the grid. The inverter does not feed anything into the grid at this time.
8. The inverter can start feeding energy into the grid again after performing the grid checks required by the relevant standard.

# All-pin separation cabling variant, e.g. Germany, France, Spain, UK

---

## Functions

- Measuring and transferring the required parameters for energy management and Solar.web by the Fronius Smart Meter.
  - Disconnecting from the public grid to enable operation in backup power mode if the grid parameters are outside the country-specific standards.
  - Reconnecting to the public grid when the grid parameters are within the limits specified by the country-specific standards.
  - Establishing a proper ground connection for backup power mode to ensure the protection devices function correctly.
  - Option of having a separate backup power circuit or several backup power circuits that are supplied even during failure of the public grid. The total load of the backup power circuits must not exceed the nominal output of the inverter. Furthermore, the performance of the connected battery must also be considered.
- 

## Transitioning from feeding energy into the grid to backup power mode

1. The public grid is monitored by the inverter's internal grid and system protection unit and by the Fronius Smart Meter connected to it.
2. **Failure of the public grid.**
3. The inverter carries out the necessary measures according to the country standard and then switches off.  
Contactors K1, K2 (K2 - optional in France and Spain), K4 and K5 drop out. This disconnects the backup power circuits and the inverter from the rest of the home network and from the public grid, as the main contacts of the contactors K1 and K2 open at all pins. The NC auxiliary contacts of contactors K1 and K2 send feedback to the inverter that the contactors are open (a condition for starting backup power mode).
4. The NC main contacts of contactors K4 and K5 are closed, establishing a connection between the neutral conductor and the ground conductor. The two other NC main contacts of contactors K4 and K5 give feedback to the inverter that the ground connection has been established correctly (a condition for starting backup power mode).
5. The inverter activates relay K3, which interrupts the supply to contactors K1, K2, K4 and K5. This prevents unintentional activation of contactors K1, K2, K4 and K5 and thus a grid connection when voltage is restored in the grid.
6. The NO contact of relay K3 gives additional feedback to the inverter on whether the locking was successfully performed by relay K3.
7. The inverter decides based on the contactor's feedback as well as the measurements on the inverter terminals and the Smart Meter that the emergency power mode can be activated.
8. After all the required activation tests have been carried out, the inverter starts backup power mode.
9. All loads in the backup power circuits are supplied with power. The remaining loads are not supplied with power and are safely isolated.

---

**Transitioning  
from backup  
power mode to  
feeding energy  
into the grid**

1. The inverter is operating in backup power mode. The contactors K1 and K2 to the public grid are open.
2. **Public grid available again.**
3. The Fronius Smart Meter monitors the grid parameters on the public grid and passes this information to the inverter.
4. The stability of the returned public grid is determined by checking the measured values of the Fronius Smart Meter.
5. The inverter ends backup power mode and disconnects the outputs.
6. The inverter deactivates K3. Power is restored to contactors K1, K2, K4 and K5.
7. All circuits are reconnected to the public grid and are supplied by the grid. The inverter does not feed anything into the grid at this time.
8. The inverter can start feeding energy into the grid again after performing the grid checks required by the relevant standard.

# All-pin split separation cabling variant (Italy)

---

## Functions

- Measuring and transferring the required parameters for energy management and Solar.web by the Fronius Smart Meter.
  - Monitoring of the voltage and frequency grid parameters by the inverter.
  - Disconnecting from the public grid to enable operation in backup power mode if the grid parameters are outside the country-specific standards.
  - Reconnecting to the public grid when the grid parameters are within the limits specified by the country-specific standards.
  - Establishing a correct ground connection for backup power mode.
  - Option of having a separate backup power circuit or several backup power circuits that are supplied even during failure of the public grid. The total load of the backup power circuits must not exceed the nominal output of the inverter. Furthermore, the performance of the connected battery must also be considered.
- 

## Transitioning from feeding energy into the grid to backup power mode

1. The public grid is monitored by the inverter's internal grid and system protection unit and by an external grid and system protection unit.
2. **Failure of the public grid**
3. The inverter carries out the measures necessary according to the country standard and then switches off.
4. The external grid and system protection unit opens contactors K1 and K2 for grid monitoring. This disconnects the backup power circuits and the inverter from the rest of the home network and from the public grid, as the main contacts of the contactors K1 and K2 open at all pins. To ensure that the public grid has definitely been disconnected, the NC auxiliary contacts of contactor K1 give feedback to the external grid and system protection unit.
5. The NC main contact of contactors K4 and K5 is closed, establishing a connection between the neutral conductor and the ground conductor. The two other NC main contacts of contactors K4 and K5 give feedback to the inverter that the ground connection has been established correctly.
6. The inverter activates relay K3, which activates the remote input of the external grid and system protection unit via an NC contact. This prevents a connection to the public grid when voltage is restored in the grid.
7. The NO contact of relay K3 gives additional feedback to the inverter on whether the locking was successfully performed by relay K3.
8. The inverter decides based on the contactors' feedback as well as the measurement on the inverter terminals and the Smart Meter that backup power mode can be started.
9. The inverter starts backup power mode after a defined checking period.
10. All loads in the backup power circuits are supplied with power. The remaining loads are not supplied with power and are safely isolated.

---

**Transitioning from backup power mode to feeding energy into the grid**

1. The inverter is operating in backup power mode. The contactors K1 and K2 to the public grid are open.
2. **Public grid available again.**
3. The Fronius Smart Meter monitors the grid parameters on the public grid and passes this information to the inverter.
4. The stability of the returned public grid is determined by checking the measured values of the Fronius Smart Meter.
5. On the basis of adjustments that have been carried out, the inverter ends backup power mode and disconnects the outputs.
6. The inverter deactivates K3. Power is restored to contactors K1, K2, K4 and K5.
7. All circuits are reconnected to the public grid and are supplied by the grid. The inverter does not feed anything into the grid at this time.
8. The inverter can start feeding energy into the grid again after performing the grid checks required by the relevant standard.

# Installation

## Quick-lock system

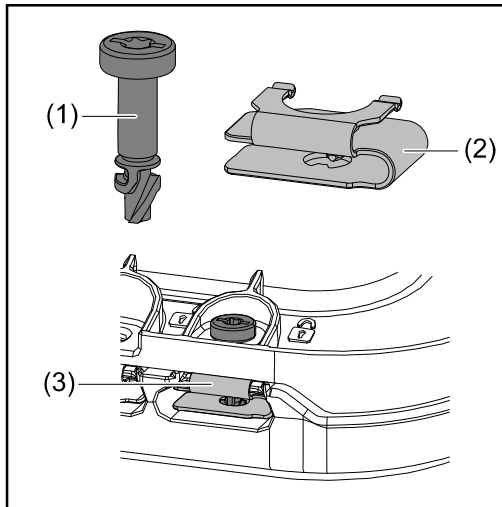

A quick-lock system (3) is used to mount the connection area cover and front cover. The system is opened and closed with a half-rotation (180°) of the captive screw (1) into the quick-lock spring (2).

The system is independent of torque.

### NOTE!

#### **Danger when using a drill driver.**

This may result in the destruction of the quick-lock system due to overtorque.

- ▶ Use a screwdriver (TX20).
- ▶ Do not turn the screws more than 180°.

## Warning notices on the device

Technical data, warning notices and safety symbols are affixed to the inverter. These warning notices and safety symbols must not be removed or painted over. They warn against incorrect operation which can lead to serious injury and damage.



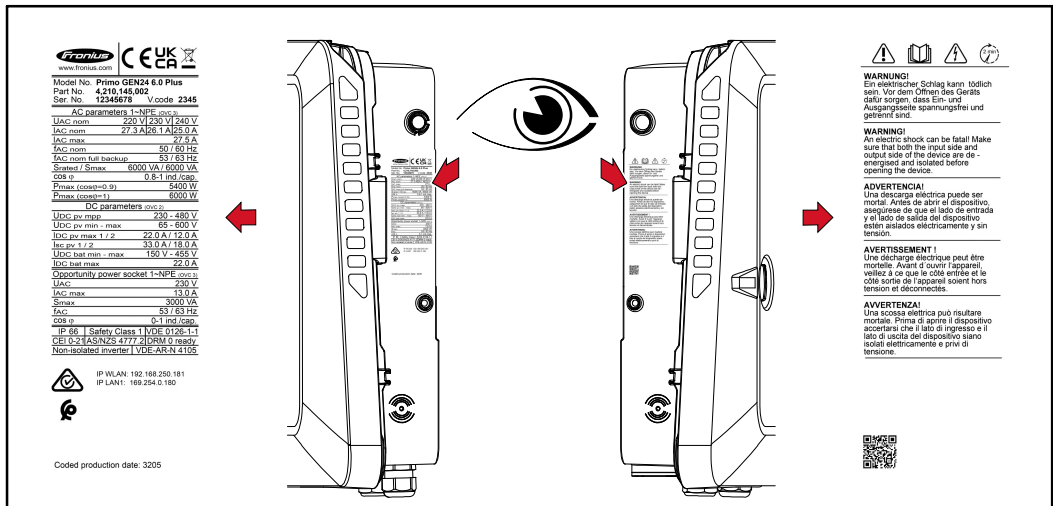

A 4-digit number (coded production date) is printed on the rating plate at the very bottom, from which the production date can be calculated.

If you subtract the value 11 from the first two digits, you get the production year. The last two digits stand for the calendar week in which the device was produced.

**Example:**

Value on rating plate = **3205**

**32** - 11 = 21 → Production year 2021

**05** = Calendar week 05

**Symbols on the rating plate:**

**CE** CE mark – confirms compliance with applicable EU directives and regulations.

**UK CA** UKCA mark – confirms compliance with applicable UK directives and regulations.

WEEE mark – waste electrical and electronic equipment must be collected separately and recycled in an environmentally sound manner in accordance with the European Directive and national law.

RCM mark – tested in accordance with the requirements of Australia and New Zealand.

ICASA mark – tested in accordance with the requirements of the Independent Communications Authority of South Africa.

CMIM mark – tested in accordance with IMANOR requirements for import regulations and compliance with Moroccan standards.

**Safety symbols:**

Risk of serious injury and property damage due to incorrect operation.

Do not use the functions described here until you have fully read and understood the following documents:  
 - These Operating Instructions.  
 - All Operating Instructions for the system components of the photovoltaic system, especially the safety rules.

Dangerous electrical voltage.

Allow the capacitors of the inverter to discharge (2 minutes).

# Installation location and position

## Choosing the location of the inverter

Please note the following criteria when choosing a location for the inverter:

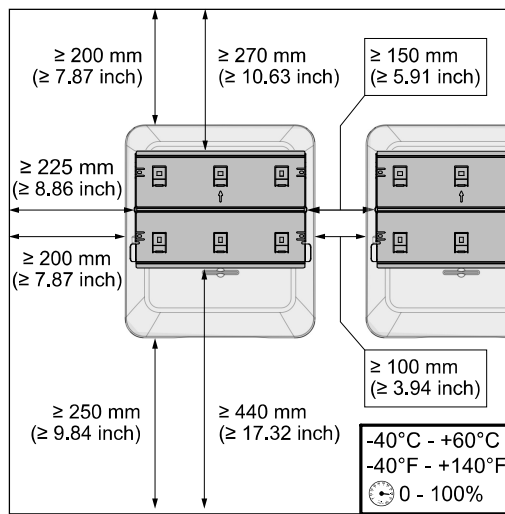

Only install on a solid, non-flammable surface.

Max. ambient temperatures:  
-40 °C - +60 °C  
-40 °F - +140 °F

Relative humidity:  
0-100%

If the inverter is installed in a switch cabinet or similar enclosed space, ensure sufficient heat dissipation with forced-air ventilation.

For detailed information on the dimensions of the inverter, see chapter **Fronius Primo GEN24 3 - 6 kW** on page 179.

When installing the inverter on the outer walls of cattle sheds, it is important to maintain a minimum clearance of 2 m between the inverter and the ventilation and building openings on all sides.

The following surfaces are permissible for installation:

- Walls (corrugated metal walls [mounting rails], brick walls, concrete walls or other non-flammable surfaces sufficiently capable of bearing loads)
- Poles (installed using mounting rails, behind the solar modules directly on the PV mounting system)
- Flat roofs (if this is for a film roof, make sure that the films comply with the fire protection requirements and are not highly flammable. Ensure compliance with the national provisions.)
- Covered car park roofs (no overhead installation)

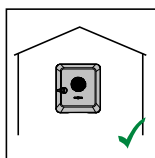

The inverter is suitable for indoor installation.

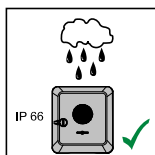

The inverter is suitable for outdoor installation.

Because of its IP 66 protection class, the inverter is resistant to water jets from any direction and can also be used in damp environments.

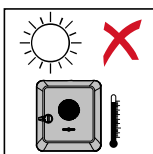

In order to minimise the heating up of the inverter, do not expose it to direct insolation. The inverter should be installed in a protected location, for example, near the solar modules or under an overhanging roof.

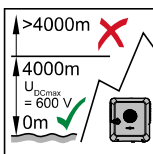
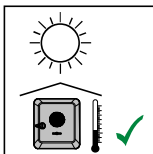

**IMPORTANT!** The inverter must not be installed or used at altitudes above 4000 m.

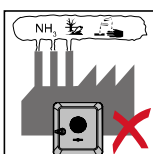

Do not install the inverter in:

- Areas where it may be exposed to ammonia, corrosive gases, acids or salts (e.g. fertiliser storage areas, vent openings for live-stock stables, chemical plants, tanneries, etc.)

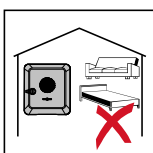

During certain operating phases the inverter may produce a slight noise. For this reason it should not be installed in an occupied living area.

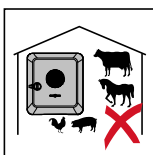

Do not install the inverter in:

- Areas where there is an increased risk of accidents from farm animals (horses, cattle, sheep, pigs, etc.)
- Stables or adjoining areas
- Storage areas for hay, straw, chaff, animal feed, fertilizers, etc.



The inverter is essentially designed to be dustproof (IP 66). In areas of high dust accumulation, dust deposits may collect on the cooling surfaces, and thus impair the thermal performance. Regular cleaning is required in this case, see chapter [Operation in dusty environments](#) on page 139. We therefore recommend not installing the inverter in areas and environments with high dust accumulation.

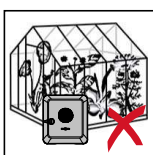

Do not install the inverter in:

- Greenhouses
- Storage or processing areas for fruit, vegetables or viticulture products
- Areas used in the preparation of grain, green fodder or animal feeds

### Choosing the location of third-party batteries

#### **IMPORTANT!**

Refer to the manufacturer's documents for the suitable location for third-party batteries.

**Explanation of symbols for the installation position**

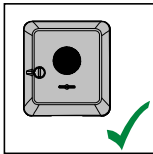

The inverter is suitable for vertical installation on a vertical wall or column.

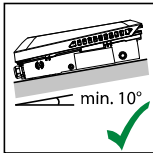
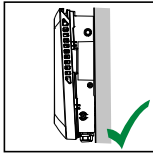

The inverter is suitable for installation on a sloping surface (min. slope to underside 10°).

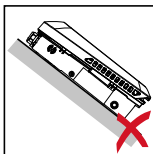

Do not install the inverter on a sloping surface with its connection sockets at the top.

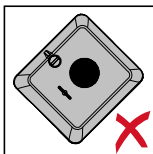

Do not install the inverter at an angle on a vertical wall or column.

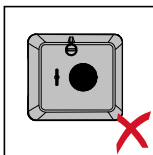

Do not install the inverter horizontally on a vertical wall or pillar.

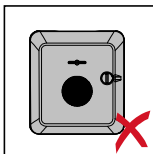

Do not install the inverter on a vertical wall or pillar with its connection sockets facing upwards.

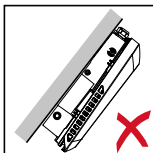
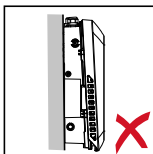

Do not install the inverter overhanging with the connection sockets at the top.

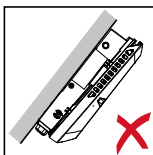

Do not install the inverter overhanging with the connection sockets at the bottom.

# Install the mounting bracket and hang up the inverter

## Selecting the fixing material

Use the corresponding fixing materials depending on the subsurface and observe the screw dimension recommendations for the mounting bracket.  
The installer is responsible for selecting the right type of fixing.

## Properties of the mounting bracket

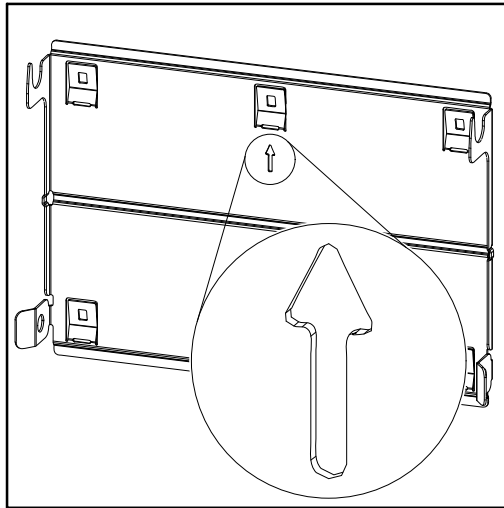

The mounting bracket (illustration) can also be used as a guide.

The pre-drilled holes on the mounting bracket are intended for screws with a thread diameter of 6-8 mm (0.24-0.32 inches). The distance from the left to the right pre-drilled hole is 406 mm (16 inches).

Unevenness on the mounting surface (such as coarse-textured plaster) is largely compensated by the mounting bracket.

## Do not deform the mounting bracket

### NOTE!

**When fitting the mounting bracket to the wall or column, ensure that the mounting bracket does not become deformed.**

A deformed mounting bracket may make it difficult to clip/swivel the inverter into position.

## Fitting the mounting bracket to a wall

### IMPORTANT!

When installing the mounting bracket, make sure that it is installed with the arrow pointing upwards.

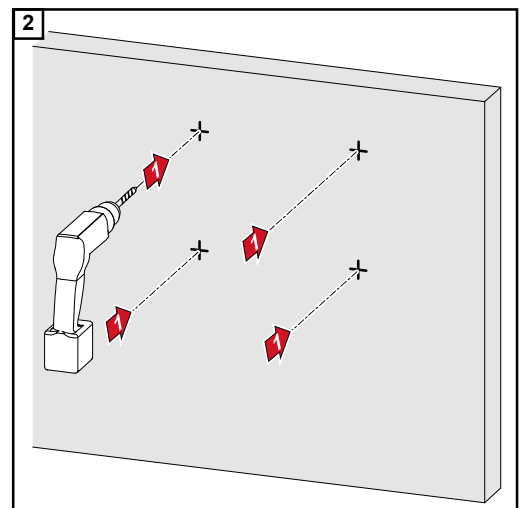
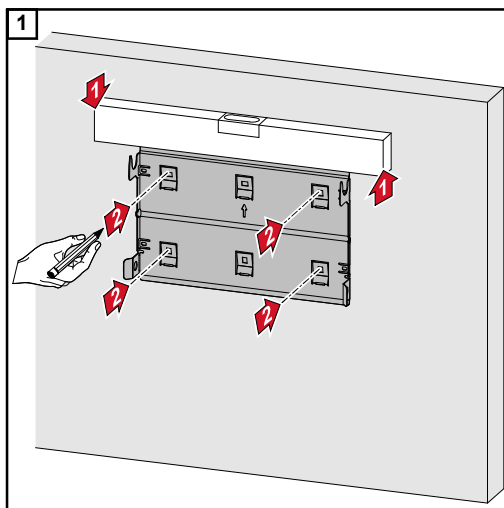

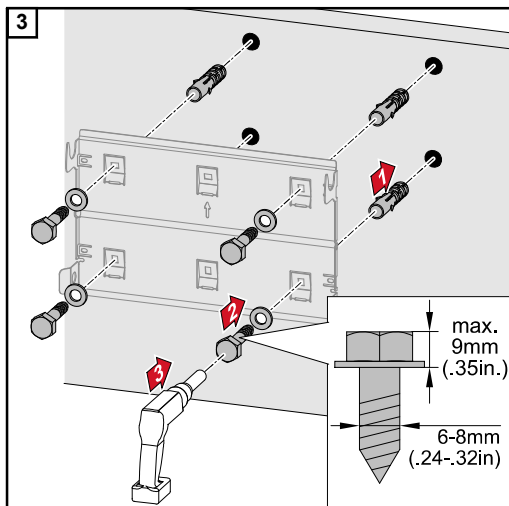

### Installing the mounting bracket on a mast or beam

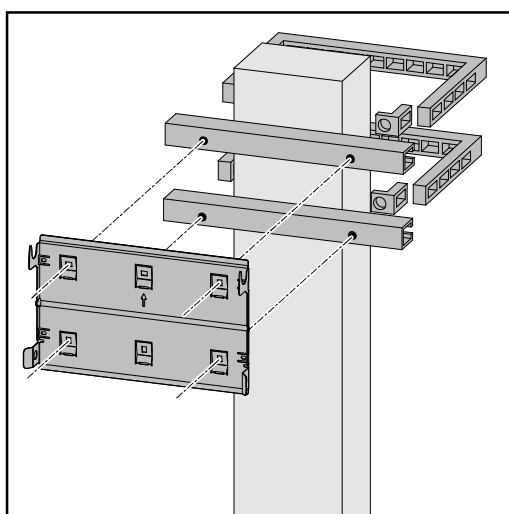

When installing the inverter on a mast or beam, Fronius recommends using the "Pole clamp" (order no. SZ 2584.000) mounting kit from Rittal GmbH.

The "Pole clamp" kit covers the following dimensions:

- Rectangular mast or beam with a side length of 50-150 mm (1.97-5.91 inches)
- Round mast or beam with a diameter of 40-190 mm (1.57-7.48 inches)

### Attaching the mounting bracket to mounting rails

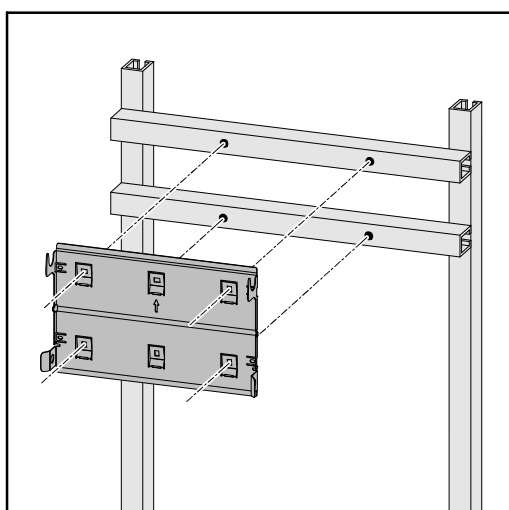

### IMPORTANT!

The mounting bracket must be affixed at a minimum of four points.

**Attaching the inverter to the mounting bracket**

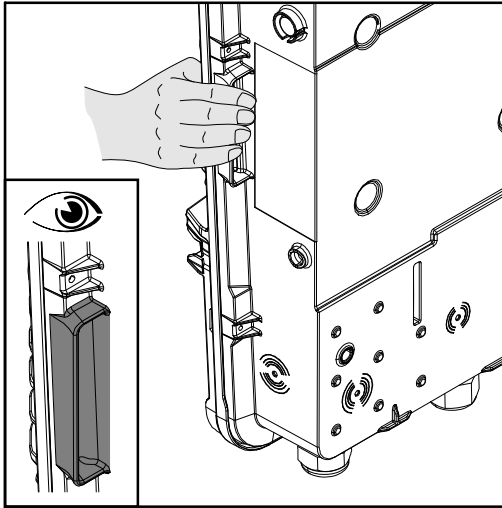

There are integrated grips on the side of the inverter which facilitate lifting/attaching.

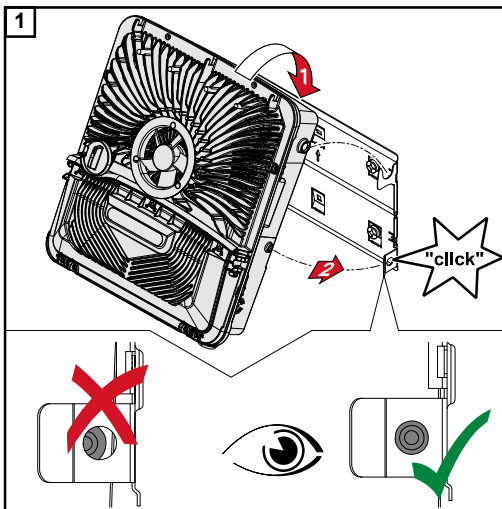

Clip the inverter into the mounting bracket from above. The connections must point downwards.

The lower area of the inverter is pushed into the snap-in tabs until the inverter audibly clicks into place on both sides.

Check that the inverter is correctly positioned on both sides.

# Prerequisites for connecting the inverter

**Permitted cables** Cables with the following design can be connected to the terminals of the inverter:



- Copper: round, solid



- Copper: round, fine-stranded, up to conductor class 4

## Grid connections with push-in terminal\*

Select a sufficiently large cable cross section based on the actual device output!

| Power categories  | Solid                              | Multi-stranded                     | Fine-stranded                      | Fine-stranded with ferrules with/without collar |
|-------------------|------------------------------------|------------------------------------|------------------------------------|---|
| 3–6 kW<br>(3-pin) | 2.5–10 mm <sup>2</sup><br>AWG 14–8 | 2.5–10 mm <sup>2</sup><br>AWG 14–8 | 2.5–10 mm <sup>2</sup><br>AWG 14–8 | 2.5–6 mm <sup>2</sup><br>AWG 14–10              |

## Grid connections backup power with push-in terminal\*

Select a sufficiently large cable cross section based on the actual device output.

| Power categories  | Solid                              | Multi-stranded                     | Fine-stranded                      | Fine-stranded with ferrules with/without collar |
|-------------------|------------------------------------|------------------------------------|------------------------------------|---|
| 3–6 kW<br>(3-pin) | 1.5–10 mm <sup>2</sup><br>AWG 16–8 | 1.5–10 mm <sup>2</sup><br>AWG 16–8 | 1.5–10 mm <sup>2</sup><br>AWG 16–8 | 1.5–6 mm <sup>2</sup><br>AWG 16–10              |

## PV/BAT connections with push-in terminal\*\*

Select a sufficiently large cable cross section based on the actual device output.

| Power categories      | Solid                            | Multi-stranded                   | Fine-stranded                    | Fine-stranded with ferrules with/without collar |
|-----------------------|----------------------------------|----------------------------------|----------------------------------|---|
| 3–6 kW<br>(2 x 5-pin) | 4–10 mm <sup>2</sup><br>AWG 12–8 | 4–10 mm <sup>2</sup><br>AWG 12–8 | 4–10 mm <sup>2</sup><br>AWG 12–8 | 4–6 mm <sup>2</sup><br>AWG 12–10                |

## Ground electrode terminal (6-pin)

Select a sufficiently large cable cross section based on the actual device output.

| Number of pins | Solid                              | Multi-stranded                     | Fine-stranded                      | Fine-stranded with ferrules with/without collar |
|----------------|------------------------------------|------------------------------------|------------------------------------|---|
| 2              | 2.5–16 mm <sup>2</sup><br>AWG 14–6 | 2.5–16 mm <sup>2</sup><br>AWG 14–6 | 2.5–16 mm <sup>2</sup><br>AWG 14–6 | 2.5–16 mm <sup>2</sup><br>AWG 14–6              |
| 4              | 2.5–10 mm <sup>2</sup><br>AWG 14–8 | 2.5–10 mm <sup>2</sup><br>AWG 14–8 | 2.5–10 mm <sup>2</sup><br>AWG 14–8 | 2.5–10 mm <sup>2</sup><br>AWG 14–8              |



\* According to product standard IEC 62109, the ground conductor must correspond to the phase cross-section for phase cross-sections ≤16 mm<sup>2</sup>; for phase cross-sections >16 mm<sup>2</sup>, it must correspond to at least 16 mm<sup>2</sup>.

\*\* The cable cross section must be dimensioned in accordance with the installation situation and the specifications of the battery manufacturer.



**Permitted cables for the data communication area**

Cables with the following design can be connected to the terminals of the inverter:

-  - Copper: round, solid
-  - Copper: round, fine-stranded

**IMPORTANT!**

Connect the individual conductors to an appropriate ferrule if several individual conductors are connected to one input of the push-in terminals.

| WSD connections with push-in terminal |                    |                                       |                                       |   |  |  |
|---------------------------------------|--------------------|---------------------------------------|---------------------------------------|---|--|--|
| Distance max.                         | Stripping length   | Solid                                 | Fine-stranded                         | Fine-stranded with ferrules with collar | Fine-stranded with ferrules without collar | Cable recommendation                     |
| 100 m<br>109 yd                       | 10 mm<br>0.39 inch | 0.14-1.5 mm <sup>2</sup><br>AWG 26-16 | 0.14-1.5 mm <sup>2</sup><br>AWG 26-16 | 0.14-1 mm <sup>2</sup><br>AWG 26-18     | 0.14-1.5 mm <sup>2</sup><br>AWG 26-16      | min. CAT 5 UTP (unshielded twisted pair) |

| Modbus connections with push-in terminal |                    |                                       |                                       |   |  |  |
|--|--------------------|---------------------------------------|---------------------------------------|---|--|--|
| Distance max.                            | Stripping length   | Solid                                 | Fine-stranded                         | Fine-stranded with ferrules with collar | Fine-stranded with ferrules without collar | Cable recommendation                   |
| 300 m<br>328 yd                          | 10 mm<br>0.39 inch | 0.14-1.5 mm <sup>2</sup><br>AWG 26-16 | 0.14-1.5 mm <sup>2</sup><br>AWG 26-16 | 0.14-1 mm <sup>2</sup><br>AWG 26-18     | 0.14-1.5 mm <sup>2</sup><br>AWG 26-16      | min. CAT 5 STP (shielded twisted pair) |

| IO connections with push-in terminal |                    |                                       |                                       |   |  |                           |
|--------------------------------------|--------------------|---------------------------------------|---------------------------------------|---|--|---------------------------|
| Distance max.                        | Stripping length   | Solid                                 | Fine-stranded                         | Fine-stranded with ferrules with collar | Fine-stranded with ferrules without collar | Cable recommendation      |
| 30 m<br>32 yd                        | 10 mm<br>0.39 inch | 0.14-1.5 mm <sup>2</sup><br>AWG 26-16 | 0.14-1.5 mm <sup>2</sup><br>AWG 26-16 | 0.14-1 mm <sup>2</sup><br>AWG 26-18     | 0.14-1.5 mm <sup>2</sup><br>AWG 26-16      | Single conductor possible |

| LAN connections  |
|--|
| Fronius recommends using at least CAT 5 STP (shielded twisted pair) cables and a maximum distance of 100 m (109 yd). |

**Cross section of the AC cable**

For a standard M32 metric screw joint with a reducer:  
Cable diameter from 7-15 mm

When using an M32 metric screw joint (reducer removed):  
cable diameter from 11-21 mm  
(with a cable diameter of less than 11 mm, the strain-relief force is reduced from 100 N to a maximum of 80 N)

With cable diameters greater than 21 mm, the M32 screw joint must be replaced by an M32 screw joint with a larger clamping area – item number: 42,0407,0780 – strain-relief device M32 x 1.5 KB 18–25.

**Cross section of the DC cable**

Cable diameter for the strain-relief device: max. 9 mm.  
 Cable diameter for the connection to the push-in terminal: max. 7 mm

**IMPORTANT!**

For double-insulated cables with a cable diameter over 7 mm, the outer layer of insulation must be removed to connect to the push-in terminal.

**Maximum alternating current fuse protection**

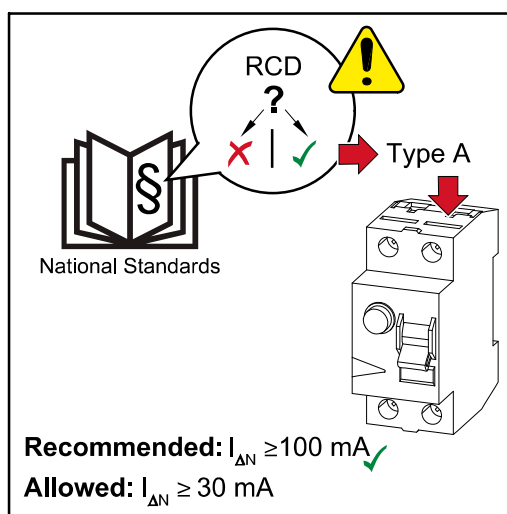

**NOTE!**

**National regulations, the grid operator's specifications or other factors may require a residual current circuit breaker in the AC connection lead.**

For this situation, a type A residual current circuit breaker is generally adequate. Nevertheless, false alarms can be triggered for the type A residual current circuit breaker in individual cases and depending on local conditions. For this reason, in accordance with national legislation, Fronius recommends that a residual current circuit breaker with a tripping current of at least 100 mA suitable for frequency converters be used.

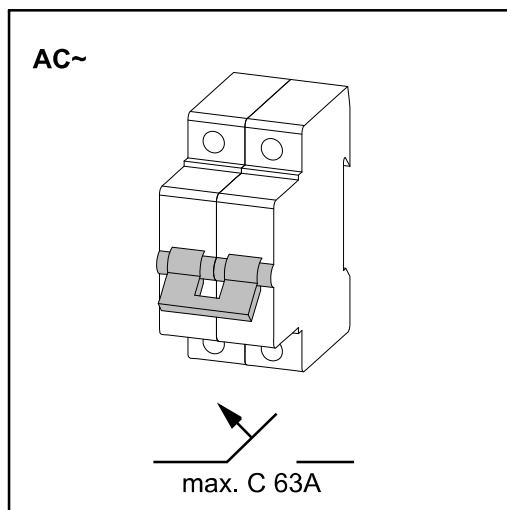

**IMPORTANT!**

The inverter can be fused with max. an automatic circuit breaker C 63 A.

| Inverter                   | Phases | AC output | Maximum fuse rating | Recommended fuse rating |
|----------------------------|--------|-----------|---------------------|-------------------------|
| Fronius Primo GEN24 3.0 kW | 1      | 3000 W    | C 63 A              | C 32 A                  |
| Fronius Primo GEN24 3.6 kW | 1      | 3680 W    | C 63 A              | C 32 A                  |
| Fronius Primo GEN24 4.0 kW | 1      | 4000 W    | C 63 A              | C 40 A                  |
| Fronius Primo GEN24 4.6 kW | 1      | 4600 W    | C 63 A              | C 40 A                  |

| <b>Inverter</b>            | <b>Phases</b> | <b>AC output</b> | <b>Maximum fuse rating</b> | <b>Recommended fuse rating</b> |
|----------------------------|---------------|------------------|----------------------------|--------------------------------|
| Fronius Primo GEN24 5.0 kW | 1             | 5000 W           | C 63 A                     | C 40 A                         |
| Fronius Primo GEN24 6.0 kW | 1             | 6000 W           | C 63 A                     | C 40 A                         |

# Connecting the inverter to the public grid (AC side)

## Safety

### **WARNING!**

#### **Danger due to incorrect operation and incorrectly performed work.**

This can result in serious injury and damage to property.

- ▶ Read the Installation and Operating Instructions before installing and commissioning the equipment.
- ▶ Only qualified personnel are authorised to commission your inverter and only within the scope of the respective technical regulations.

### **WARNING!**

#### **Danger due to grid voltage and DC voltage from solar modules that are exposed to light.**

An electric shock can be fatal.

- ▶ Prior to any connection work, disconnect the inverter on the AC side and the DC side.
- ▶ Only an authorised electrical engineer is permitted to connect this equipment to the public grid.

### **WARNING!**

#### **Danger due to damaged and/or contaminated terminals.**

This can result in serious injury and damage to property.

- ▶ Before making any connections, check the terminals for damage and contamination.
- ▶ Remove contamination in the de-energized state.
- ▶ Have defective terminals repaired by an authorised specialist.

### **IMPORTANT!**

National standards and guidelines regarding load unbalance must be taken into account. The inverter does not have a communication link and does not automatically disconnect from the grid when the load unbalance is exceeded.

If the inverter is installed in Australia or New Zealand (required standard: AS/NZS4777.2:2020), the inverter must not be used as part of a three-phase combination, as there is no communication link between the inverters.

## Connecting the inverter to the public grid (AC side)

### **NOTE!**

#### **The neutral conductor must be connected in order to operate the inverter.**

It is not possible to operate the inverter in unearthed grids, such as IT grids (insulated grids without ground conductor).

- ▶ Make sure that the grid's neutral conductor is grounded.

**IMPORTANT!** The ground conductor of the AC cable must be laid in such a way that it is the last to be disconnected in the event that the strain-relief device should fail.

This can be ensured by making it somewhat longer and by laying it in a loop.

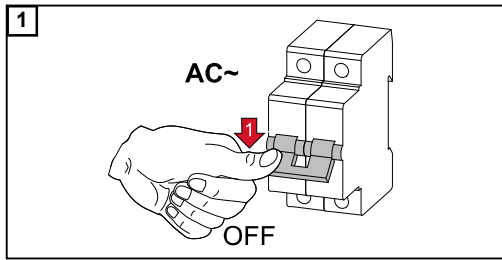

Turn off the automatic circuit breaker.

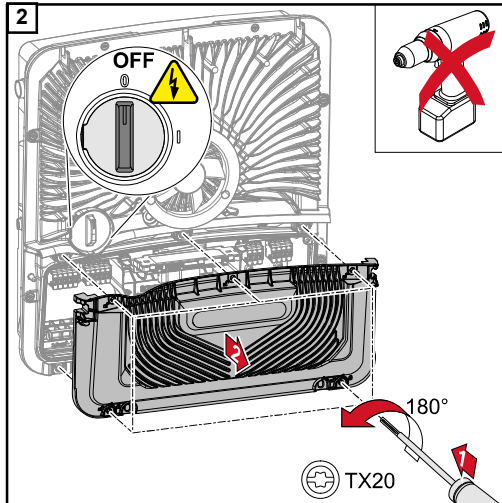

Make sure that the DC disconnect is in the "Off" switch setting.  
Loosen the five screws of the connection area cover by rotating them 180° to the left using a screwdriver (TX20).  
Remove the connection area cover from the device.

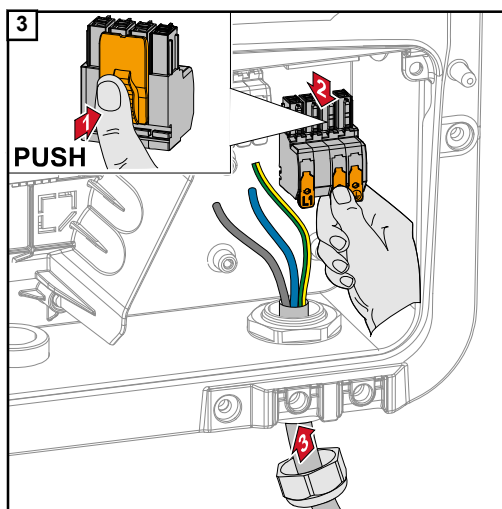

Guide the mains cable from below through the strain-relief device on the right side.  
Remove the AC terminal.

### IMPORTANT!

The ground conductor must be connected with a loop so that if the strain-relief device fails, the ground conductor is disconnected last.

For more information on the strain-relief device, see chapter [Cross section of the AC cable](#) on page 58.

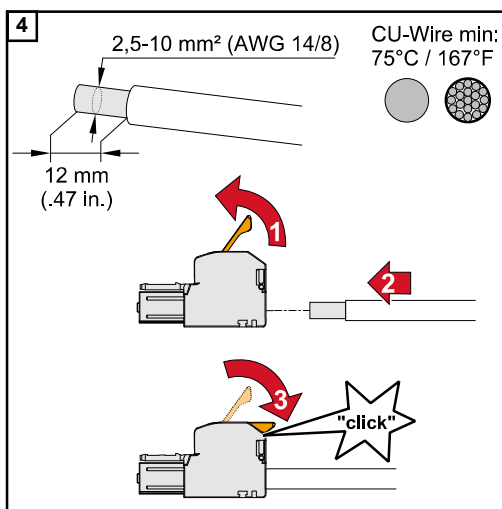

Strip the insulation of the single conductors by 12 mm.

Select the cable cross section in accordance with the instructions in [Permitted cables](#) from page 57.

Lift to open the terminal's operating lever and insert the stripped single conductor into the slot provided as far as it will go.

Then close the terminal's operating lever until it engages.

### NOTE!

**Only one conductor may be connected to each pin.**

The AC cables can be connected to the AC terminals without ferrules.

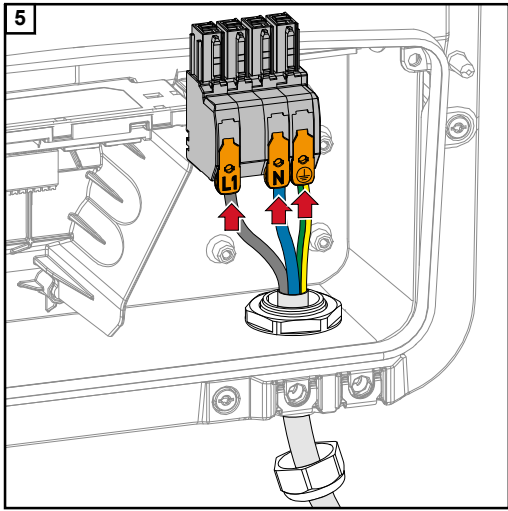

- L1 Phase conductor
- N Neutral conductor
- PE Ground conductor

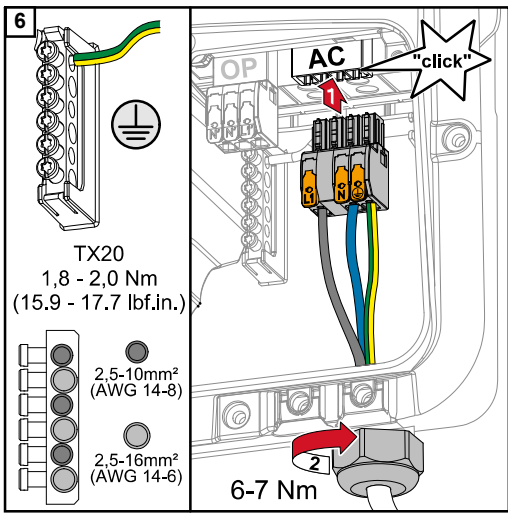

Insert the AC terminal into the AC slot until it engages. Fasten the union nut of the strain-relief device with a torque of 6-7 Nm.

# Connecting solar module strings to the inverter

## General comments regarding solar modules

To enable suitable solar modules to be chosen and to use the inverter as efficiently as possible, it is important to bear the following points in mind:

- If insolation is constant and the temperature is falling, the open circuit voltage of the solar modules will increase. The open circuit voltage must not exceed the maximum permissible system voltage. If the open circuit voltage exceeds the specified values, the inverter will be destroyed and no warranty claims will be entertained.
- The temperature coefficients on the data sheet of the solar modules must be observed.
- Exact values for sizing the solar modules can be obtained using suitable calculation tools, such as the [Fronius Solar.configurator](#).

### IMPORTANT!

Before connecting up the solar modules, check that the voltage for the solar modules specified by the manufacturer corresponds to the actual measured voltage.

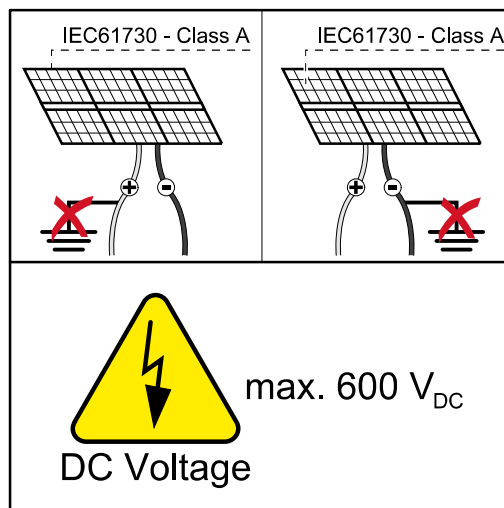

### IMPORTANT!

The solar modules connected to the inverter must comply with the IEC 61730 Class A standard.

### IMPORTANT!

Solar module strings must not be earthed.

## Safety

### WARNING!

#### **Incorrect operation or poorly executed work can cause serious injury or damage.**

Commissioning as well as maintenance and service work in the power module of the inverter must only be carried out by service personnel trained by Fronius and only within the scope of the respective technical regulations. Read the Installation and Operating Instructions before installing and commissioning the equipment.

### WARNING!

#### **An electric shock can be fatal.**

Danger due to grid voltage and DC voltage from solar modules that are exposed to light.

- ▶ Ensure that the AC and DC side of the inverter are de-energised before carrying out any connection/maintenance or service tasks.
- ▶ Only an authorised electrical engineer is permitted to connect this equipment to the public grid.

**⚠ WARNING!**

**Danger due to damaged and/or contaminated terminals.**

This can result in serious injury and damage to property.

- ▶ Before making any connections, check the terminals for damage and contamination.
- ▶ Remove contamination in the de-energized state.
- ▶ Have defective terminals repaired by an authorised specialist.

**PV generator -  
general informa-  
tion**

2 independent PV inputs (PV 1 and PV 2) are available. These can be connected to a different number of modules.

When using for the first time, set up the PV generator according to the respective configuration (also possible later in the "System configuration" menu under the "Components" menu item).

**PV generator  
configuration  
3 - 6 kW**

**IMPORTANT!**

The installation must be carried out in accordance with the nationally applicable standards and directives. If the arc detection integrated in the inverter is used for the requirement according to IEC 63027 for arc detection, the solar module strings must not be combined upstream of the inverter.

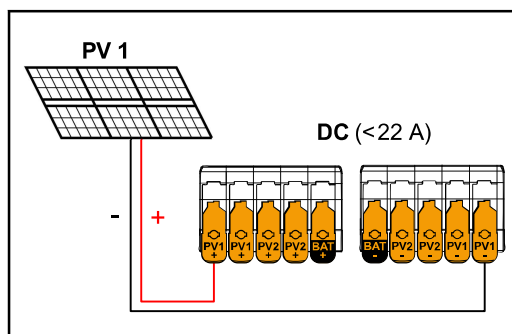

Total current ( $I_{dcmax}$ ) less than 22 A

**MPPT settings:**

PV 1: **ON**

PV 2: **OFF**

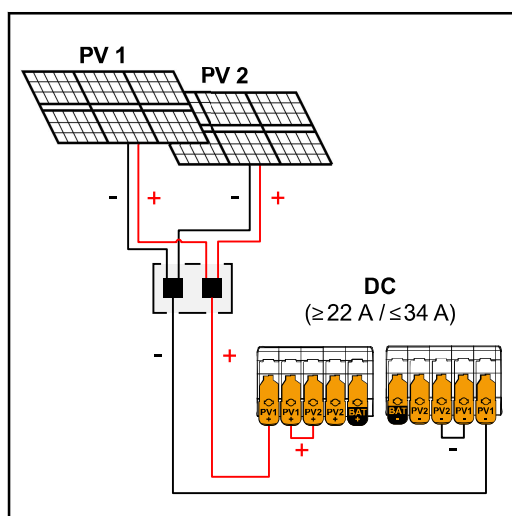

Combined solar module strings with total current ( $I_{dcmax}$ ) greater than or equal to 22 A

**MPPT settings:**

PV 1: **ON**

PV 2: **OFF**

PV 1 + PV 2 (connected in parallel): **ON**

**IMPORTANT!**

Splitting the total current ( $I_{dcmax}$ ) by bridging from PV 1 to PV 2 at the terminal is permitted up to  $\le 34\text{ A}$ .



**Connecting the solar module strings to the inverter**

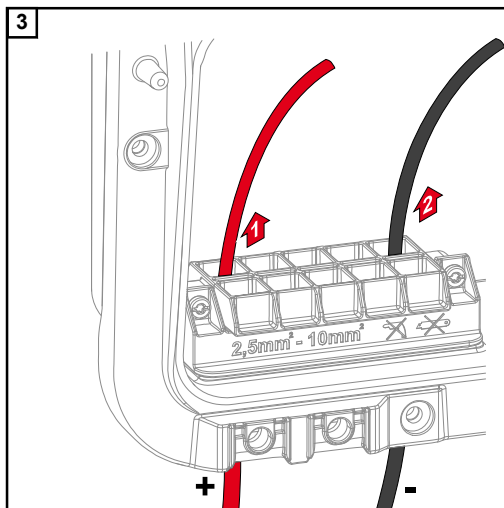
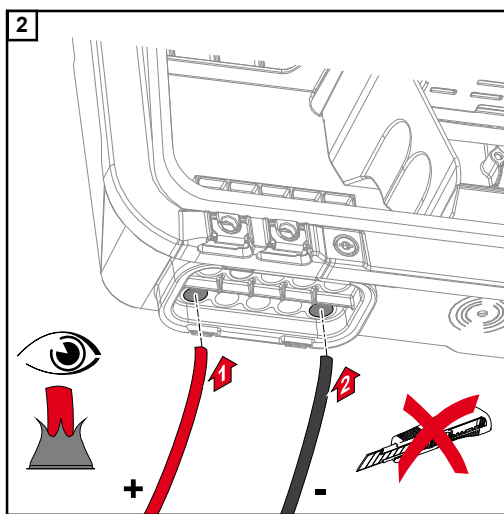
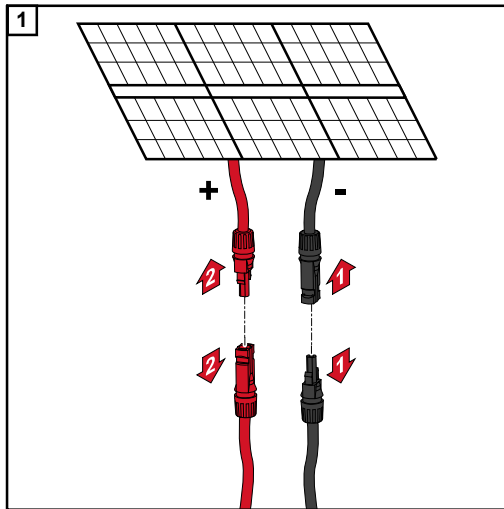

Push the DC cables through the DC bushings by hand.

**IMPORTANT!**  
Before stripping the insulation, push the cables through the DC bushings to prevent individual wires being bent or broken.

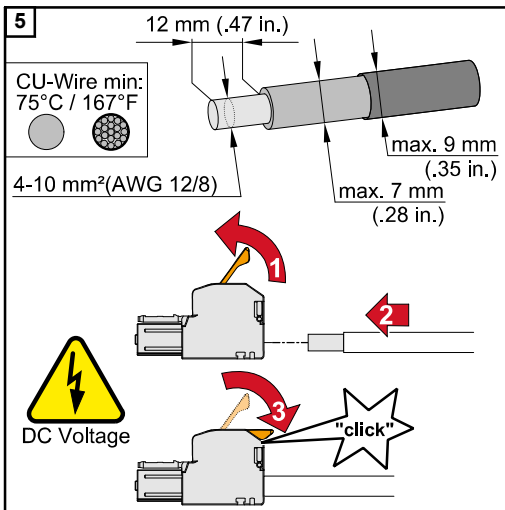
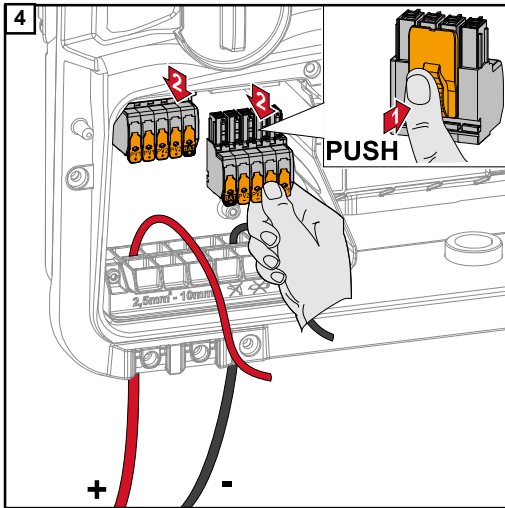

Select the cable cross section in accordance with the instructions in **Permitted cables** from page 57. Strip the insulation of the single conductors by 12 mm. Lift to open the terminal's operating lever and insert the stripped single conductor into the slot provided, in each case as far as it will go. Then close the operating lever until it engages.

**NOTE!**

**No multi-wire connections are possible with this terminal type.** Only one conductor may be connected to each pin. The DC cables can be connected to the DC terminals without ferrules.

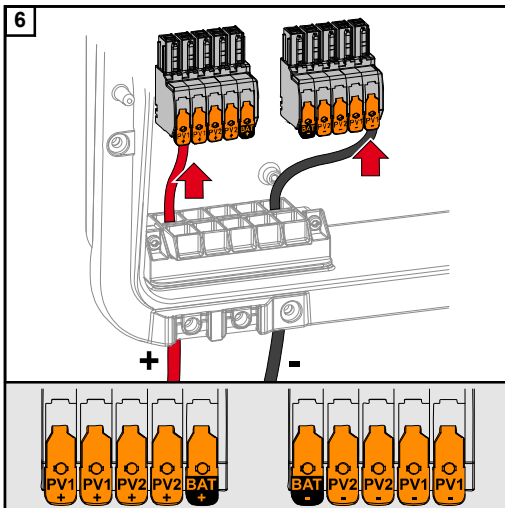

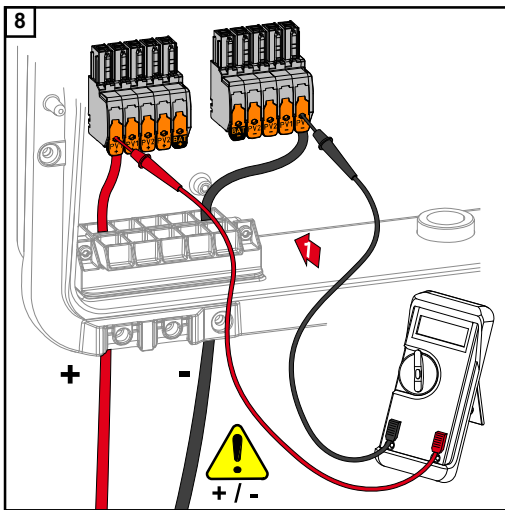
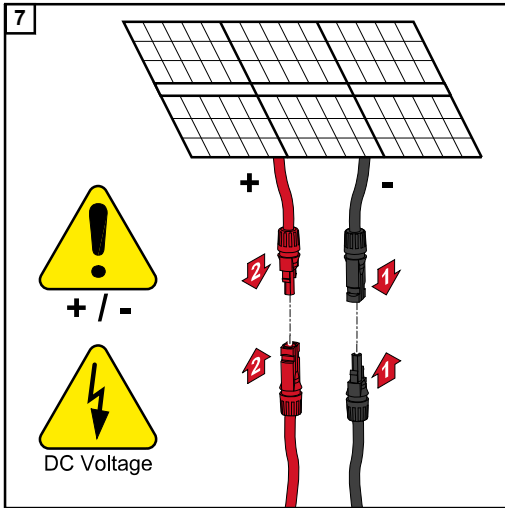

Use a suitable measuring instrument to check the voltage and polarity of the DC cabling. Remove both DC terminals from the slots.

**CAUTION!**

**Danger due to polarity reversal at the terminals.**

This may result in severe damage to the inverter.

- ▶ Use a suitable measuring instrument to check the polarity of the DC cabling.
- ▶ Use a suitable measuring instrument to check the voltage (**max. 600 V<sub>DC</sub>**)

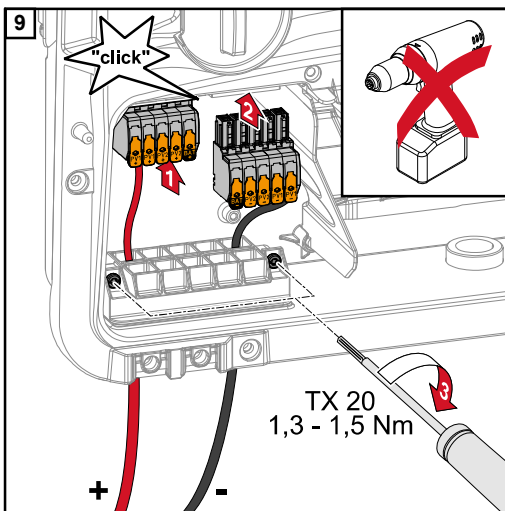

Insert the DC terminals into the respective slot until they engage. Fasten the screws of the cable guide to the housing using a screwdriver (TX20) and a torque of 1.3-1.5 Nm.

**NOTE!**

**Do not use a drill driver as this could cause overturning.**

A possible consequence of overturning is, for example, damaging the strain-relief device.

# Connecting the battery to the inverter

## Safety

### **WARNING!**

**Incorrect operation or poorly executed work can cause serious injury or damage.** Commissioning as well as maintenance and service work on the inverter and battery must only be carried out by service personnel trained by the respective inverter or battery manufacturer and only within the scope of the respective technical regulations. Read the Installation and Operating Instructions provided by the respective manufacturer before installing and commissioning the equipment.

### **WARNING!**

#### **An electric shock can be fatal.**

Danger due to grid voltage and DC voltage from solar modules that are exposed to light and from batteries.

- ▶ Ensure that the AC and DC side of the inverter and the battery are de-energised before carrying out any connection/maintenance or service tasks.
- ▶ Only an authorised electrical engineer is permitted to connect this equipment to the public grid.

### **WARNING!**

#### **Danger due to damaged and/or contaminated terminals.**

This can result in serious injury and damage to property.

- ▶ Before making any connections, check the terminals for damage and contamination.
- ▶ Remove contamination in the de-energised state.
- ▶ Have defective terminals repaired by an authorised specialist.

## Connecting the battery on the DC side

### **CAUTION!**

#### **Risk due to operation of the battery above the permissible altitude as specified by the manufacturer.**

Operating the battery above the permissible altitude can result in restricted operation, failure of the operation and unsafe states of the battery.

- ▶ Adhere to the manufacturer's instructions regarding the permissible altitude.
- ▶ Operate the battery only at the altitude specified by the manufacturer.

#### **IMPORTANT!**

Prior to installing a battery, ensure that the battery is switched off. Refer to the manufacturer's documents for the max. length of the DC cables for installing third-party batteries.

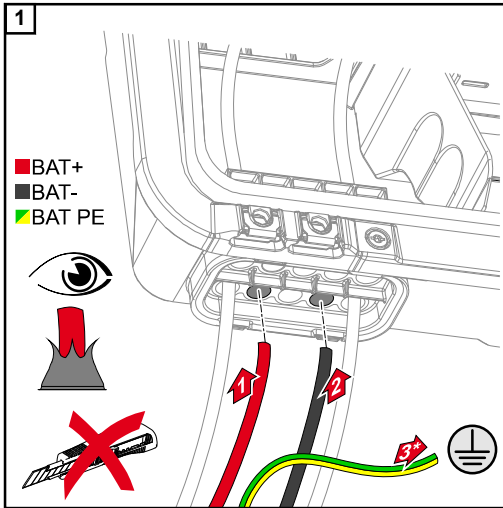

Manually push the BAT cables through the DC bushings.

\* Connect the ground conductor of the battery to an external point (e.g. switch cabinet). In doing so, the minimum cross section of the battery's ground conductor must be observed.

**IMPORTANT!**

Before stripping the insulation, push the cables through the DC bushings to prevent individual wires being bent or broken.

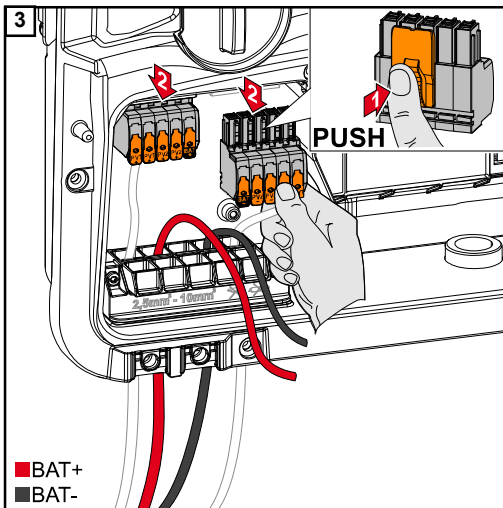
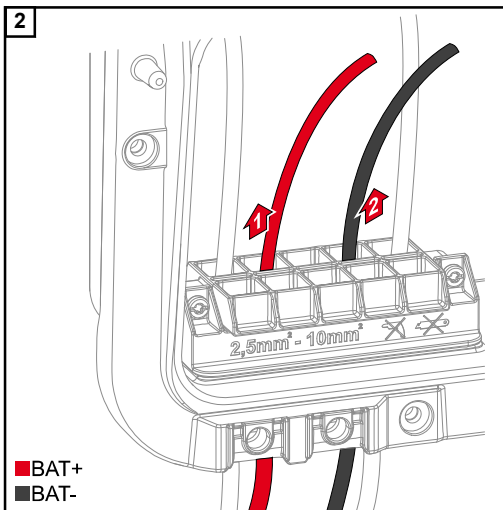

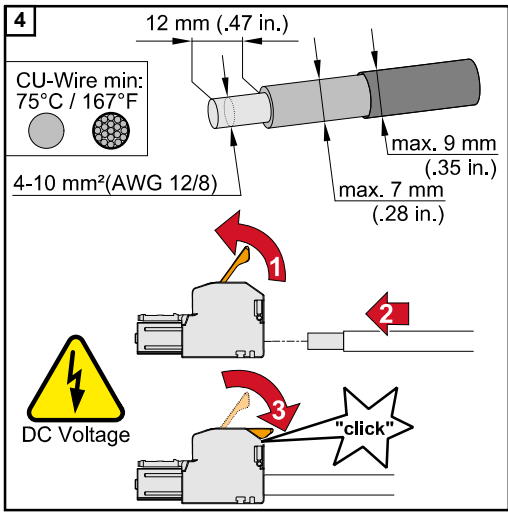

Select the cable cross section in accordance with the instructions in **Permitted cables** from page 57. Strip the insulation of the single conductors by 12 mm. Lift to open the terminal's operating lever and insert the stripped single conductor into the slot provided, in each case as far as it will go. Then close the operating lever until it engages.

**NOTE!**

**No multi-wire connections are possible with this terminal type.** Only one conductor may be connected to each pin. The DC cables can be connected to the DC terminals without ferrules.

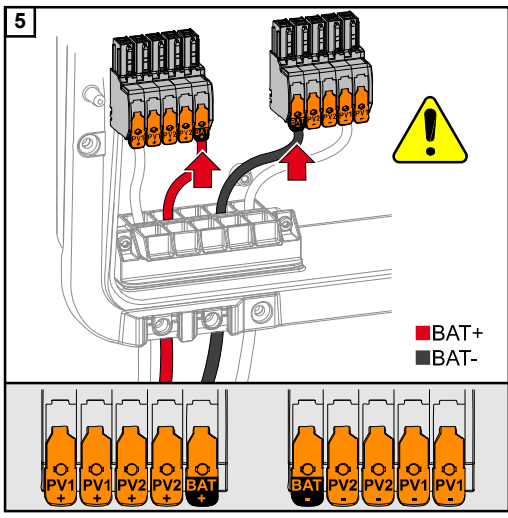

**CAUTION!**

**Risk due to overvoltage when using other slots on the terminal.** This may result in damage to the battery and/or the solar module due to discharge. Only use the designated slots for battery connection.

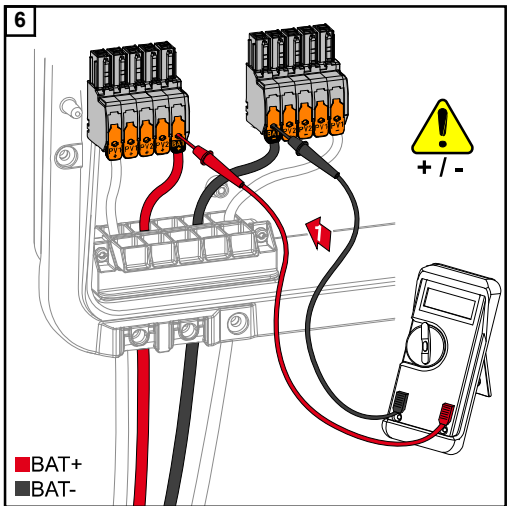

**CAUTION!**

**Danger due to polarity reversal at the terminals.** Serious substantive damage to the PV system may result. Use a suitable measuring instrument to check the polarity of the DC cabling when the battery is switched on. The maximum voltage for the battery input must not be exceeded (see **Technical data** on page 145).

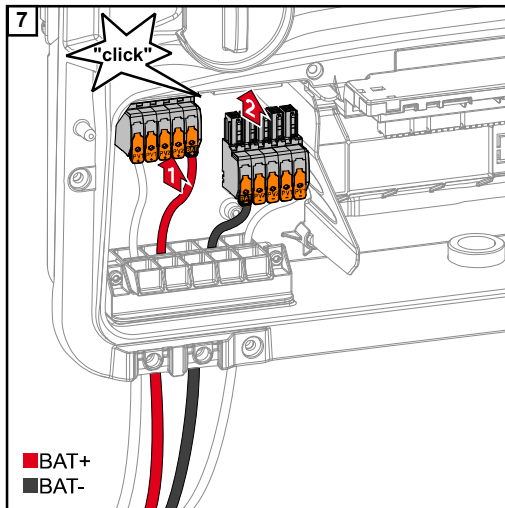

Insert the DC terminals into the respective slot until they engage.

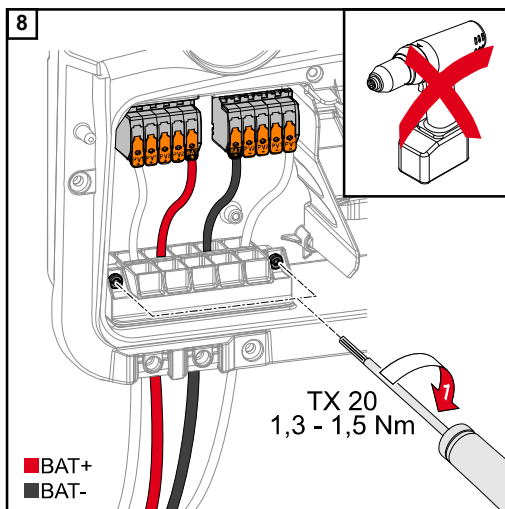

Fasten the screws of the cable guide to the housing using a screwdriver (TX20) and a torque of 1.3-1.5 Nm.

**NOTE!**

**Do not use a drill driver as this could cause overturning.**  
A possible consequence of overturning is, for example, damaging the strain-relief device.

**IMPORTANT!**

Information for connection on the battery side can be found in the Installation Instructions from the relevant manufacturer.

# Connecting backup power - PV Point (OP)

## Safety

### IMPORTANT!

The valid national laws, standards and provisions, as well as the specifications of the relevant grid operator are to be taken into account and applied.

It is highly recommended that the specific installation be agreed with the grid operator and explicitly approved by this operator. This obligation applies to system constructors in particular (e.g. installers).

### NOTE!

**The continuous supply via the PV Point depends on the available PV power.**

If the solar modules are not supplying enough power, interruptions may occur.

- ▶ Do not connect any loads that require an interruption-free supply.



### WARNING!

**Danger from incorrect installation, commissioning, operation or incorrect use.**

This can result in severe personal injury/damage to property.

- ▶ Only trained and qualified personnel are authorised to install and commission the system, and only within the scope of the technical regulations.
- ▶ The Installation and Operating Instructions must be read carefully prior to use.
- ▶ If anything is unclear, contact your vendor immediately.



### WARNING!

**Danger due to damaged and/or contaminated terminals.**

This can result in serious injury and damage to property.

- ▶ Before making any connections, check the terminals for damage and contamination.
- ▶ Remove contamination in the de-energized state.
- ▶ Have defective terminals repaired by an authorised specialist.

## Installation

### NOTE!

**All loads that have to be supplied via the OP terminal must be protected by means of a residual current circuit breaker.**

In order to ensure the residual current circuit breaker operates properly, a connection must be established between the neutral conductor N' (OP) and the earth.

For the Circuit Diagram recommended by Fronius, see [Circuit Diagram - PV Point \(OP\)](#) on page 165.



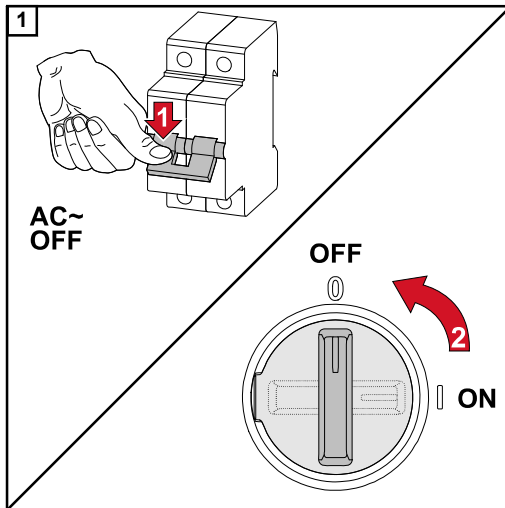

Switch off the automatic circuit breaker and DC disconnect.

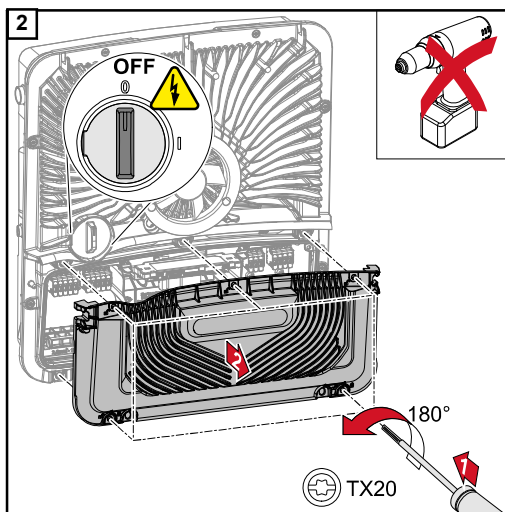

Make sure that the DC disconnect is in the "Off" switch setting.  
Loosen the five screws of the connection area cover by rotating them 180° to the left using a screwdriver (TX20).  
Remove the connection area cover from the device.

**⚠ CAUTION!**

**Danger from faulty or incorrect holes.**

This may lead to injuries to the eyes and hands as a result of flying debris and sharp edges, as well as damage to the inverter.

- ▶ When drilling, wear suitable protective goggles.
- ▶ Only use a step drill when drilling.
- ▶ Ensure that nothing is damaged inside the device (for example connection block).
- ▶ Adapt the diameter of the hole to match the corresponding connection.
- ▶ Deburr the holes using a suitable tool.
- ▶ Remove the drilling residues from the inverter.

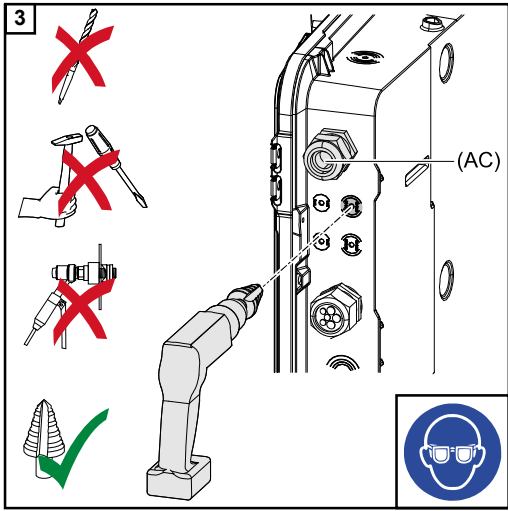

Drill out the optional cable guide with a step drill.

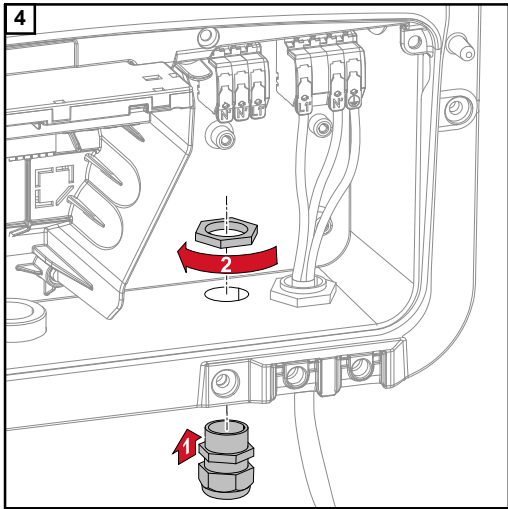

Insert the strain-relief device into the hole and secure to the torque specified by the manufacturer.

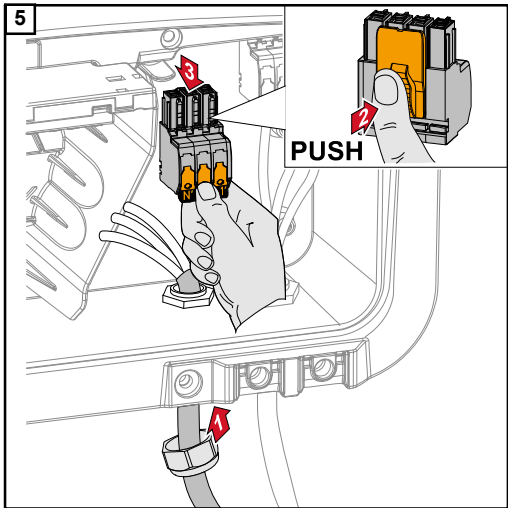

Guide the mains cable through the strain-relief device from below. Remove the OP terminal.

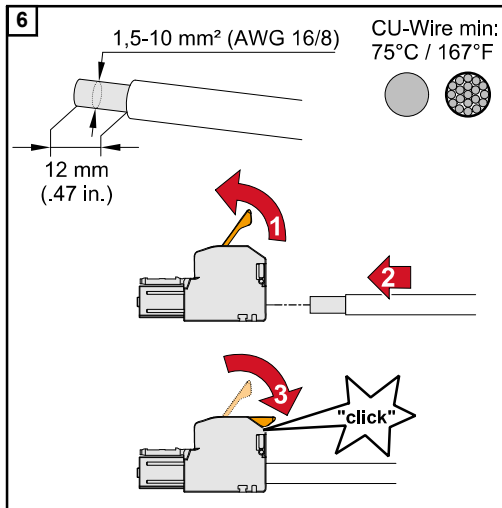

Strip the insulation of the single conductors by 12 mm. The cable cross section must be between 1.5 mm<sup>2</sup> and 10 mm<sup>2</sup>. Lift to open the terminal's operating lever and insert the stripped single conductor into the slot provided, all the way up to the stop. Then close the operating lever until it engages.

**NOTE!**

Only one conductor may be connected to each pin. The conductors can be connected without ferrules.

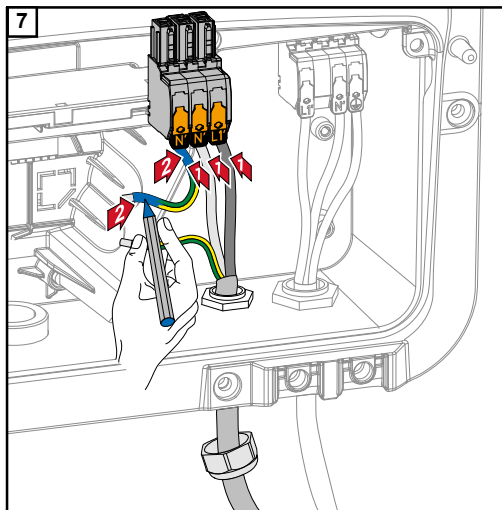

- L1' Phase conductor
- N' Neutral conductor
- N' PEN conductor

**NOTE!**

The PEN conductor must be produced with ends that are permanently marked blue, according to the national provisions, and have a cross section of 10 mm<sup>2</sup>.

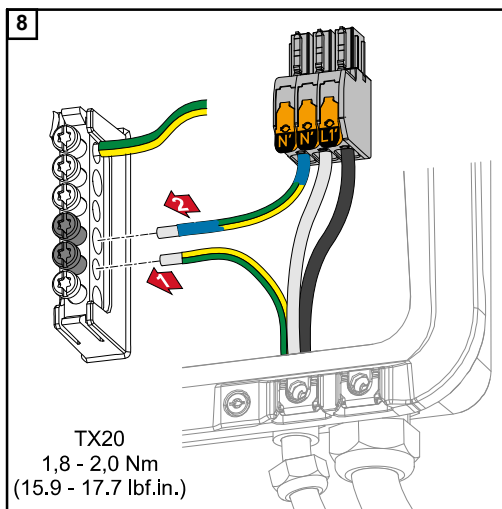

Fasten the ground conductor and PEN conductor to the ground electrode terminal using a screwdriver (TX20) and a torque of 1.8-2 Nm.

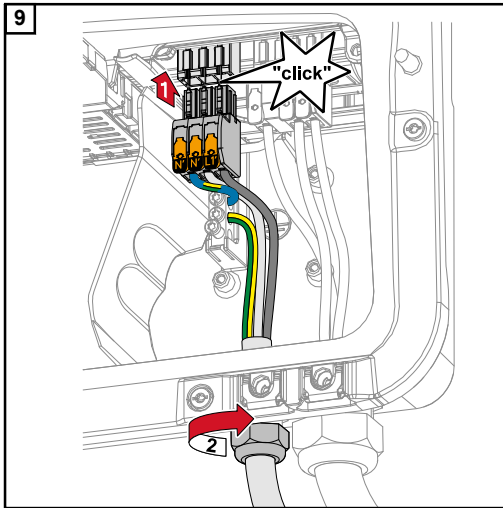

Insert the OP terminal into the OP slot until it engages. Tighten the union nut of the strain-relief device to the torque specified by the manufacturer.

# Connecting backup power - Full Backup

---

## Safety

The examples given in this document (in particular cabling variants and Circuit Diagrams) are suggestions only. These examples have been carefully developed and tested. They can therefore be used as a basis for real-life installation. Anyone following or using these examples does so at their own risk.

### IMPORTANT!

The valid national laws, standards and provisions, as well as the specifications of the relevant grid operator are to be taken into account and applied.

It is highly recommended to coordinate the concrete examples implemented and in particular the specific installation with the grid operator to obtain their explicit approval. This obligation applies to system constructors in particular (e.g. installers).

The examples suggested here show a backup power supply with or without an external protection relay (external grid and system protection unit). Whether an external protection relay must be used or not is the decision of the respective grid operator.

### IMPORTANT!

No uninterruptible power supply (UPS) must be operated in the backup power circuit. The Installation and Operating Instructions must be read carefully prior to use. If anything is unclear, contact your vendor immediately.



### WARNING!

#### **Danger from incorrect installation, commissioning, operation or incorrect use.**

This can result in severe personal injury/damage to property.

- ▶ Only trained and qualified personnel are authorised to install and commission the system, and only within the scope of the technical regulations.
  - ▶ The Installation and Operating Instructions must be read carefully prior to use.
  - ▶ If anything is unclear, contact your vendor immediately.
- 

## Cabling variants including backup power circuits with 1-pin separation e.g. Austria or Australia

### Circuit Diagram

The Circuit Diagram for the 1-pin double separation - e.g. Austria, can be found in the appendix to this document on page [169](#).

The Circuit Diagram for the 1-pin single separation - e.g. Australia, can be found in the appendix to this document on page [170](#).

---

### Cabling of backup power circuit and non-backup power circuits

If not all the loads in the home need to be supplied in a backup power situation, the circuits need to be divided into backup power circuits and non-backup power circuits. The total load of the backup power circuits must not exceed the nominal output of the inverter.

The backup power circuits and non-backup power circuits must be fused separately according to the required safety measures (residual current circuit breaker, automatic circuit breaker, etc.).

In backup power mode, only the backup power circuits are disconnected from the grid by contactors K1 and K2, 1-pin. The rest of the home network is not supplied with power in this case.

**The following points regarding cabling must be considered:**

- The main contacts of contactors K1 and K2 must be installed between the Fronius Smart Meter and the inverter and the residual current circuit breaker of the backup power circuits.
- The supply voltage for contactors K1 and K2 is provided by the public grid and must be connected to phase 1 (L1) after the Fronius Smart Meter and fused accordingly.
- An NC contact for the relay K3 interrupts the supply voltage to contactors K1 and K2. This prevents the backup power network of the inverter from being switched to the public grid.
- The NO contact of relay K3 gives feedback to the inverter on whether the locking was successfully performed by relay K3.
- Additional inverters or other AC sources can be installed in the backup power circuit after the main contacts of K1 and K2. The sources are not synchronised to the network of the inverter because this backup power network has a frequency of 53 Hz.
- The use of contactor K2 is optional in Australia.

**All-pin separation  
cabling variant  
e.g. Germany,  
France, Spain**

**Circuit Diagram**

The Circuit Diagram for the 2-pin double separation - e.g. Germany, can be found in the appendix to this document on page [171](#).

The Circuit Diagram for the 2-pin single separation - e.g. France and Spain, can be found in the appendix to this document on page [172](#).

**Cabling of backup power circuit and non-backup power circuits**

If not all the loads in the home need to be supplied in a backup power situation, the circuits need to be divided into backup power circuits and non-backup power circuits. The total load of the backup power circuits must not exceed the nominal output of the inverter.

The backup power circuits and non-backup power circuits must be fused separately according to the required safety measures (residual current circuit breaker, automatic circuit breaker, etc.).

In backup power mode, only the backup power circuits are disconnected at all pins from the grid by contactors K1 and K2; an earth connection is only established for these circuits. The rest of the home network is not supplied with power in this case.

**The following points regarding cabling must be considered:**

- The main contacts of contactors K1 and K2 must be installed between the Fronius Smart Meter and the residual current circuit breaker of the inverter and the residual current circuit breaker of the backup power circuits.
- The supply voltage for contactors K1 and K2 is provided by the public grid and must be connected to phase 1 (L1) after the Fronius Smart Meter and fused accordingly.
- To ensure residual current circuit breakers function in backup power mode, the connection between the neutral conductor and the ground conductor must be established as close as possible to the inverter, but in any case before the first residual current circuit breaker. An NC contact is used for this purpose for each of the main contacts of contactors K4 and K5. This ensures that the ground connection is established as soon as the public grid connection is no longer available.
- As with contactor K1, the supply voltage for contactors K4 and K5 is provided via phase 1 (L1) of the public grid.
- An NC contact for the relay K3 interrupts the supply voltage to contactors K1, K2, K4 and K5. This prevents the ground connection from being immediately disconnected again when power returns to the public grid and the backup power network of the inverter from being switched to the public grid.
- The NO contact of relay K3 gives feedback to the inverter on whether the locking was successfully performed by relay K3.
- The use of contactor K2 is optional in France and Spain.
- Additional inverters or other AC sources can be installed in the backup power circuit after the main contacts of K1 and K2. The sources are not synchronised to the network of the inverter because this backup power network has a frequency of 53 Hz.

---

**All-pin separation  
cabling variant,  
e.g. UK**

**Circuit Diagram**

The Circuit Diagram for the 2-pin double separation - e.g. UK, can be found in the appendix to this document on page [173](#).

---

**Cabling of backup power circuit and non-backup power circuits**

If not all the loads in the home need to be supplied in a backup power situation, the circuits need to be divided into backup power circuits and non-backup power circuits. The total load of the backup power circuits must not exceed the nominal output of the inverter.

The backup power circuits and non-backup power circuits must be fused separately according to the required safety measures (residual current circuit breaker, automatic circuit breaker, etc.).

In backup power mode, only the backup power circuits are disconnected at all pins from the grid by contactors K1 and K2; an earth connection is only established for these circuits. The rest of the home network is not supplied with power in this case.

**The following points regarding cabling must be considered:**

- The main contacts of contactors K1 and K2 must be installed between the Fronius Smart Meter and the residual current circuit breaker of the inverter and the residual current circuit breaker of the backup power circuits.
- The supply voltage for contactors K1 and K2 is provided by the public grid and must be connected to phase 1 (L1) after the Fronius Smart Meter and fused accordingly.
- To ensure residual current circuit breakers function in backup power mode, the connection between the neutral conductor and the ground conductor must be established as close as possible to the inverter, but in any case before the first residual current circuit breaker. An NC contact is used for this purpose for each of the main contacts of contactors K4 and K5. This ensures that the ground connection is established as soon as the public grid connection is no longer available.
- As with contactor K1, the supply voltage for contactors K4 and K5 is provided via phase 1 (L1) of the public grid.
- An NC contact for the relay K3 interrupts the supply voltage to contactors K1, K2, K4 and K5. This prevents the ground connection from being immediately disconnected again when power returns to the public grid and the backup power network of the inverter from being switched to the public grid.
- The NO contact of relay K3 gives feedback to the inverter on whether the locking was successfully performed by relay K3.
- Additional inverters or other AC sources can be installed in the backup power circuit after the main contacts of K1 and K2. The sources are not synchronised to the network of the inverter because this backup power network has a frequency of 53 Hz.
- A Fronius Smart Meter with current transformer is required (e.g. Fronius Smart Meter 50kA-3 or Fronius Smart Meter TS 5kA-3).

**All-pin separation cabling variant, e.g. Italy**

**Circuit Diagram**

The Circuit Diagram for the 2-pin double separation with ext. grid and system protection - e.g. Italy, can be found in the appendix to this document on page [174](#).

**Backup power circuit and non-backup power circuits**

**IMPORTANT!**

Fronius Smart Meter US-240 must be used for these circuit variants.

The backup power circuits and non-backup power circuits must be fused separately according to the required safety measures (residual current circuit breaker, automatic circuit breaker, etc.).

In backup power mode, only the backup power circuits are disconnected from the grid by contactors K1 and K2; an earth connection is only established for these circuits. The rest of the home network is not supplied with power in this case.



**The following points regarding cabling must be considered:**

- The main contacts of contactors K1 and K2 must be installed between the Fronius Smart Meter and the residual current circuit breaker of the inverter and the residual current circuit breaker of the backup power circuits.
- The supply voltage for contactors K1 and K2 is provided by the public grid and must be connected to phase 1 (L1) after the Fronius Smart Meter and fused accordingly.
- Actuation of contactors K1 and K2 is carried out by the external grid and system protection unit.
- The external grid and system protection unit must be installed after the Fronius Smart Meter. Precise installation and wiring instructions for the external grid and system protection unit can be found in its separate Operating Instructions.
- The remote trip input of the external grid and system protection unit must be set to NC according to the manufacturer's Operating Instructions.
- To ensure residual current circuit breakers function in backup power mode, the connection between the neutral conductor and the ground conductor must be established as close as possible to the inverter, but in any case before the first residual current circuit breaker. An NC contact is used for this purpose for the main contacts of contactors K4 and K5. This ensures that the ground connection is established as soon as the public grid connection is no longer available.
- The supply voltage for contactors K1, K2, K4 and K5 is provided via phase 1 (L1) of the public grid and is switched via the external grid and system protection unit.
- An NC contact for relay K3, which activates the remote input of the external grid and system protection unit, interrupts the supply voltage to contactors K1, K2, K4 and K5. This prevents the ground connection from being immediately disconnected again when power returns to the public grid and the backup power network of the inverter from being switched to the public grid.
- The NO contact of relay K3 gives additional feedback to the inverter on whether the locking was successfully performed by relay K3.
- Additional inverters or other AC sources can be installed in the backup power circuit after the main contacts of K1 and K2. The sources are not synchronised to the network of the inverter because this backup power network has a frequency of 53 Hz.

---

**Testing backup power mode**

Backup power mode should be tested once it has been installed and set up for the first time. A battery state of charge of over 30% is recommended when in test mode.

A description on how to run test mode can be found in the [backup power checklist](https://www.fronius.com/en/search-page) (https://www.fronius.com/en/search-page, item number: 42,0426,0365).

# Connecting the data communication cable

## Modbus participants

The inputs M0 and M1 can be selected for this purpose. A maximum of 4 Modbus participants can be connected to the Modbus terminal on inputs M0 and M1.

### IMPORTANT!

Only one primary meter, one battery and one Ohmpilot can be connected per inverter. Due to the high data transfer of the battery, the battery occupies 2 participants. If the "Inverter control via Modbus" function is activated in the "Communication" "Modbus" menu, no Modbus participants are possible. It is not possible to send and receive data at the same time.

### Example 1:

| Input         | Battery | Fronius Ohmpilot | Quantity Primary meter | Quantity Secondary meter |
|---------------|---------|------------------|------------------------|--------------------------|
| Modbus 0 (M0) | ✗       | ✗                | 0                      | 4                        |
|               | ✓       | ✗                | 0                      | 2                        |
|               | ✓       | ✓                | 0                      | 1                        |
| Modbus 1 (M1) | ✗       | ✗                | 1                      | 3                        |

### Example 2:

| Input         | Battery | Fronius Ohmpilot | Quantity Primary meter | Quantity Secondary meter |
|---------------|---------|------------------|------------------------|--------------------------|
| Modbus 0 (M0) | ✗       | ✗                | 1                      | 3                        |
| Modbus 1 (M1) | ✗       | ✗                | 0                      | 4                        |
|               | ✓       | ✗                | 0                      | 2                        |
|               | ✓       | ✓                | 0                      | 1                        |

## Routing data communication cables

### IMPORTANT!

If data communication cables are wired into the inverter, observe the following points:

- Depending on the number and cross section of the wired data communication cables, remove the corresponding blanking plugs from the sealing insert and insert the data communication cables.
- Make sure that you insert the corresponding blanking plugs into any free openings on the sealing insert.

### IMPORTANT!

Should the blanking plugs be missing or improperly fitted, then protection class IP66 cannot be guaranteed.

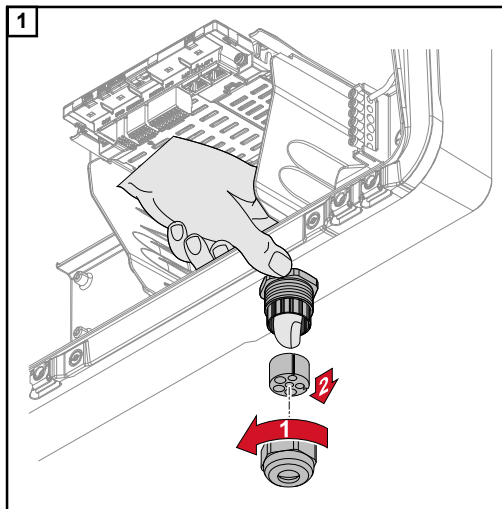

Undo the strain-relief device union nut and push out the sealing ring and the blanking plug from the inside of the device.

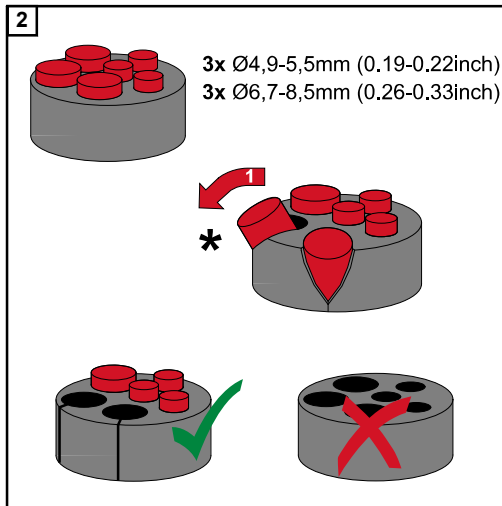

Open up the sealing ring at the location where the blanking plug is to be removed.

\* Liberate the blanking plug by moving it sideways.

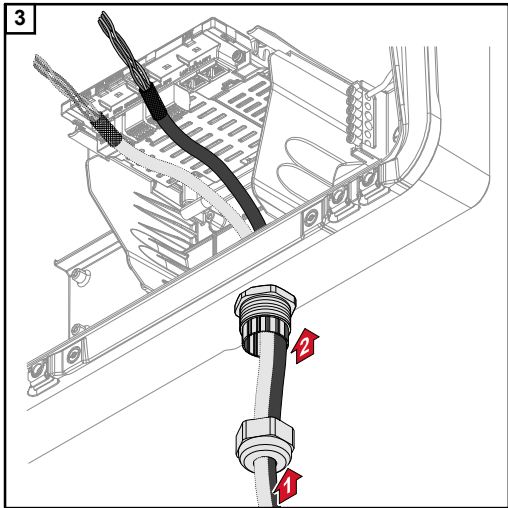

Guide the data cables first through the strain-relief device union nut and then through the housing opening.

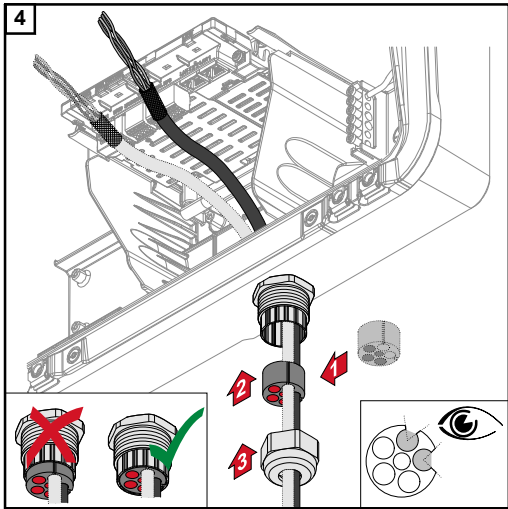

Insert the sealing ring between the union nut and the housing opening. Press the data cables into the seal's cable guide. Then press in the seal until it reaches the underside of the strain-relief device.

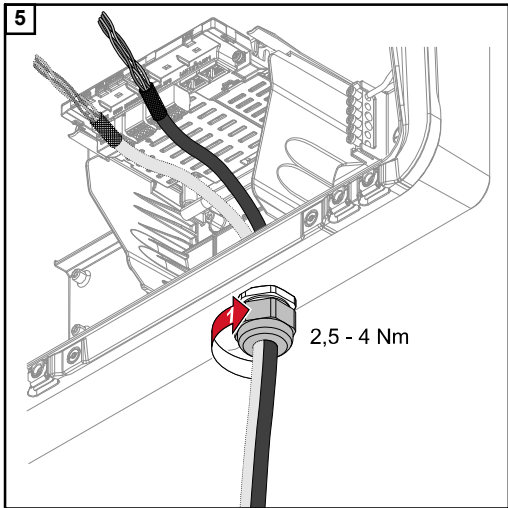

Fasten the union nut of the strain-relief device with a torque of min. 2.5 - max. 4 Nm.

## Connecting the battery communication cables

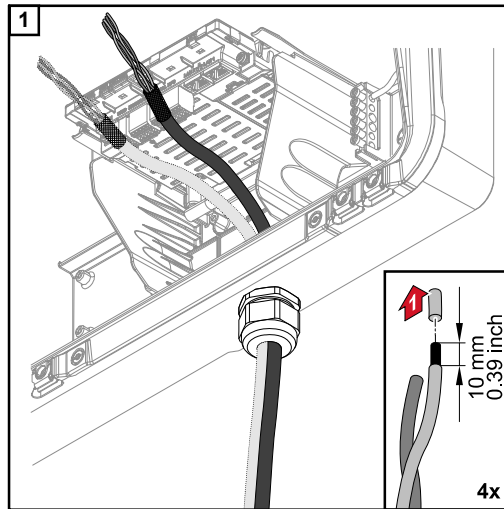

Strip 10 mm from the single conductors and mount the ferrules if necessary.

### IMPORTANT!

Connect the individual conductors to an appropriate ferrule if several individual conductors are connected to one input of the push-in terminals.

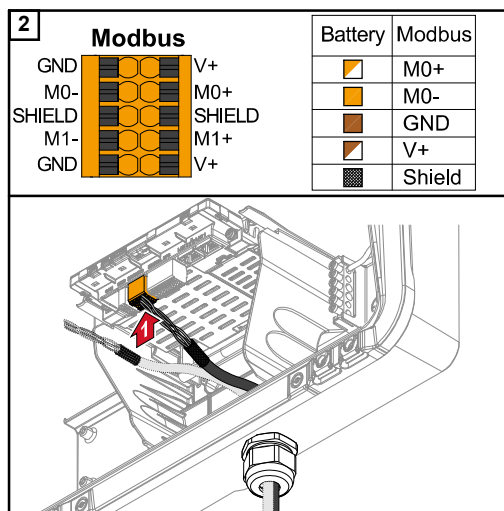

Insert the cable into the respective slot and check the cable is securely retained.

### IMPORTANT!

Use only twisted pairs for connecting "Data +/-" and "Enable +/-", see section [Permitted cables for the data communication area](#) on page 58.

Twist the cable shield and insert into the "SHIELD" slot.

### IMPORTANT!

Improperly fitted shielding can cause data communication problems.

For the wiring proposal recommended by Fronius, see page 166.

## Terminating resistors

It may be possible for the system to function without terminating resistors. However, owing to interference, the use of terminating resistors according to the following overview is recommended for trouble-free functioning.

For permissible cable and max. distances see chapter [Permitted cables for the data communication area](#) on page 58.

### IMPORTANT!

Terminating resistors that are not positioned as illustrated can result in interference in the data communication. If the terminating resistor on the battery cannot be deactivated, the battery is to be set up at the bus end (see option 2, 3).

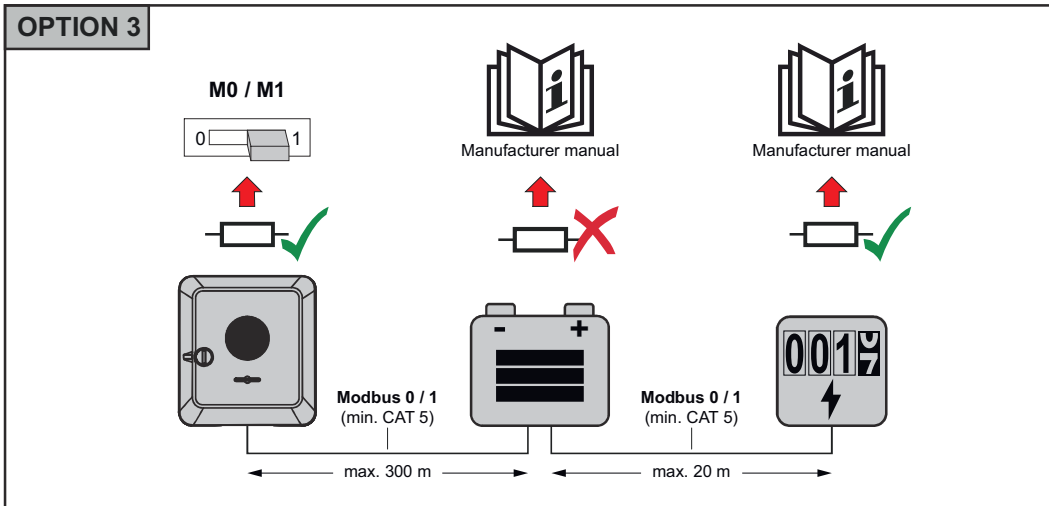
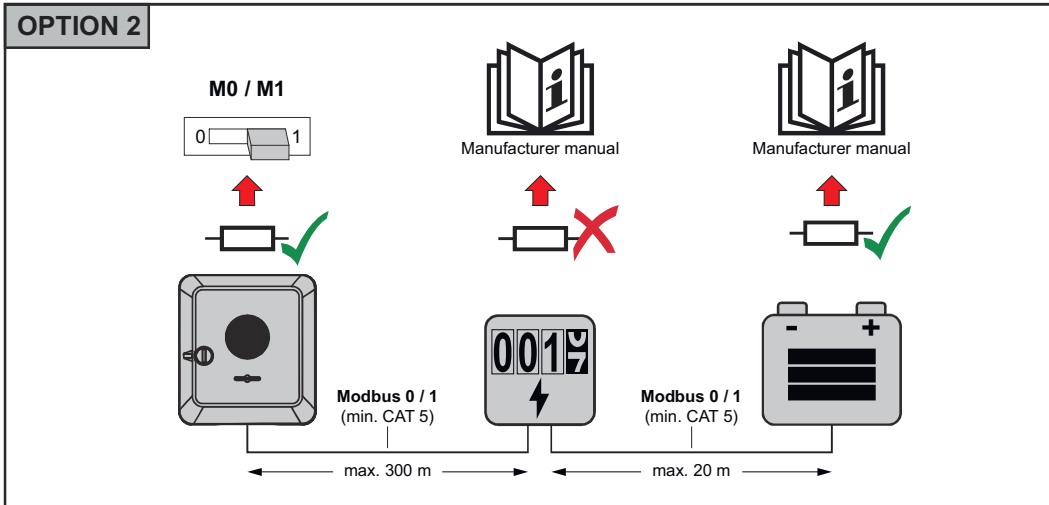
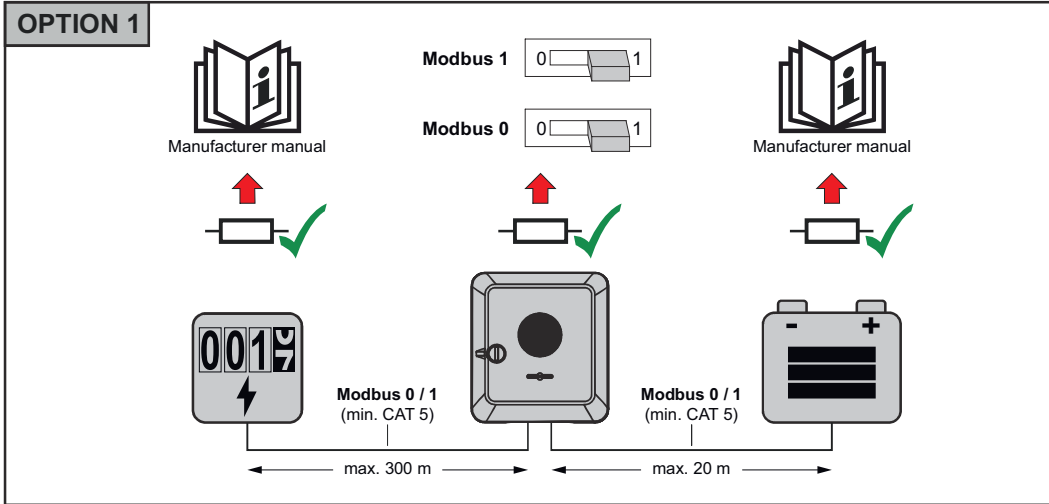

**Installing the WSD (wired shut-down)**

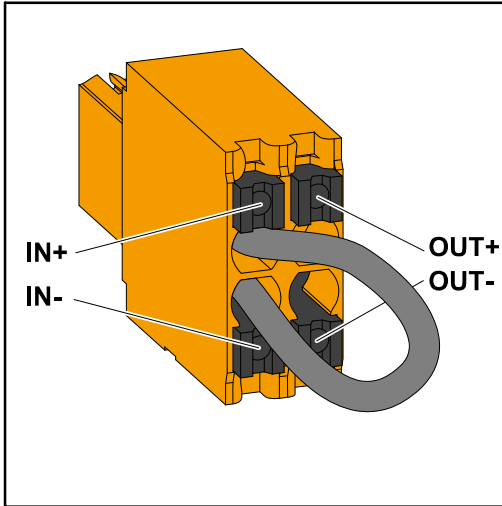

**IMPORTANT!**

The push-in WSD terminal in the inverter's connection area is delivered with a bypass ex works as standard. The bypass must be removed when installing a trigger device or a WSD chain.

The WSD switch of the first inverter with connected trigger device in the WSD chain must be in position 1 (primary device). The WSD switch of all other inverters should be in the 0 (secondary device) position.

Max. distance between two devices: 100 m  
Max. number of devices: 28

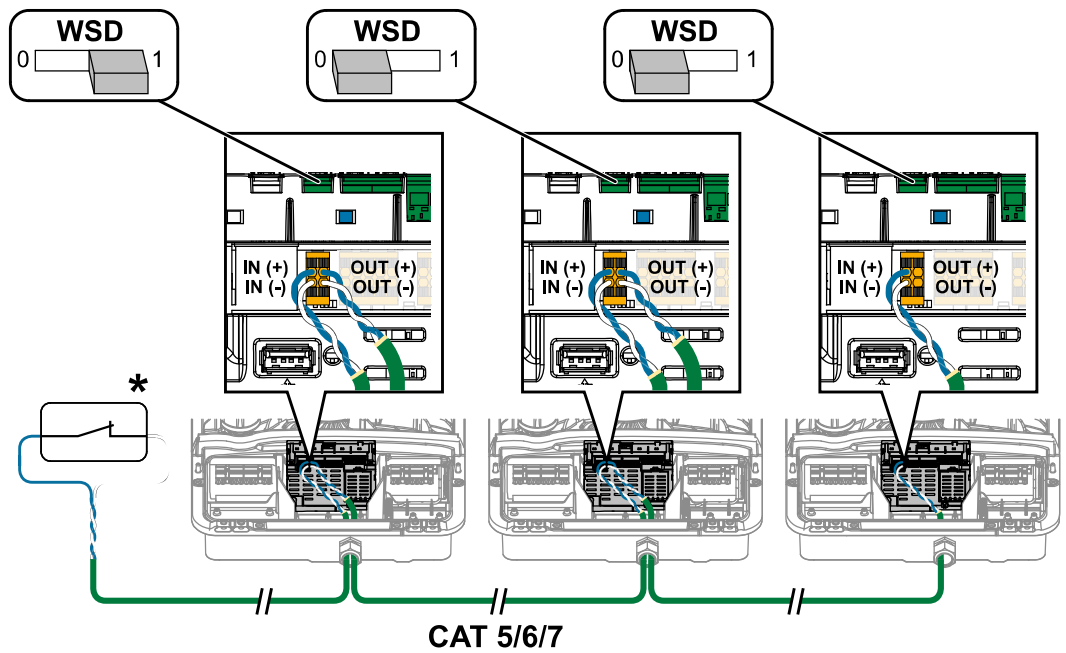

\* Floating contact of the trigger device (e.g. central grid and system protection). If several floating contacts are used in a WSD chain, they must be connected in series.

# Closing and commissioning the inverter

## Closing the inverter's connection area/housing cover, and commissioning

### NOTE!

The housing cover is fitted with a lock for safety reasons, which allows the housing cover on the inverter to be pivoted only when the DC disconnecter is switched off.

- ▶ Only clip and pivot the housing cover onto the inverter when the **DC disconnecter is switched off**.
- ▶ Do not use excessive force to clip in and pivot the housing cover.

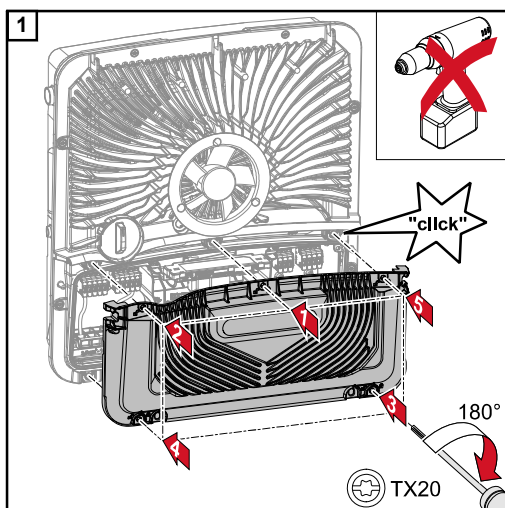

Place the cover on the connection area. Tighten the five screws by rotating them 180° to the right in the indicated order using a screwdriver (TX20).

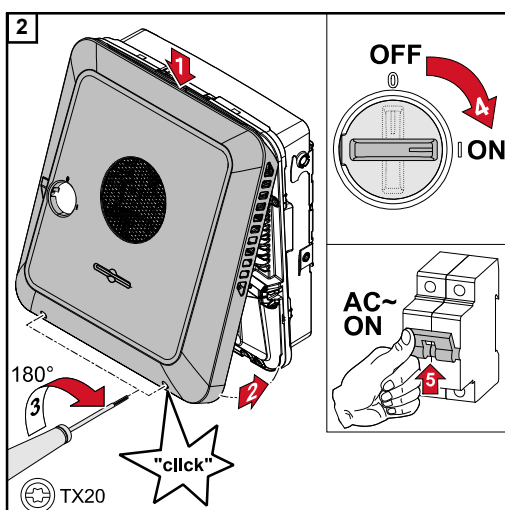

Clip the housing cover onto the inverter from above. Press on the lower part of the housing cover and tighten the two screws 180° to the right using a Torx screwdriver (TX20). Turn the DC disconnecter to the "On" switch position. Switch on the automatic circuit breaker. For systems with a battery, observe the switch-on sequence according to chapter [Suitable battery](#) on page 23.

**IMPORTANT!** Open WLAN access point with the optical sensor, see chapter [Button functions and LED status indicator](#) on page 90

## Starting the inverter for the first time

When using the inverter for the first time, various setup settings must be configured.

If the setup process is cancelled before the process is complete, any data that has been input up to this point is lost and the start screen with the installation wizard is shown again. If the process is interrupted, such as in the event of a power outage, the data is saved. Commissioning may be continued from the point at which the process was interrupted once the power supply has been restored. If the setup was interrupted, the inverter feeds energy into the grid at maximum 500 W and the operating status LED flashes yellow.



The country setup can only be set when using the inverter for the first time. If the country setup needs to be changed at a later date, please contact your installer / Technical Support team.

### Button functions and LED status indicator

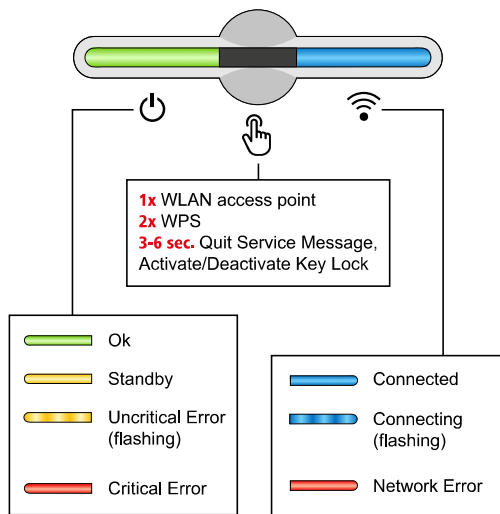

The status of the inverter is shown via the operating status LED. In the event of faults, carry out the individual steps in the Fronius Solar.start app.



The optical sensor is actuated by touching with a finger.



The status of the connection is shown via the communication LED. To establish the connection, carry out the individual steps in the Fronius Solar.start app.

### Sensor functions

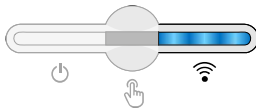

1x = WLAN access point (AP) is opened.

Flashing blue

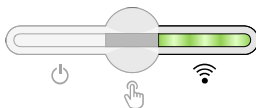

2x = WLAN Protected Setup (WPS) is activated.

Flashing green

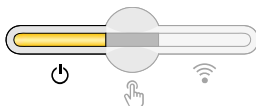

3 seconds (max. 6 seconds) = the service notification is terminated and the key lock is deactivated.

Lights up yellow

### LED status indicator

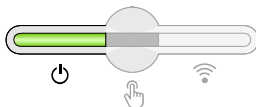

The inverter is operating correctly.

Lights up green

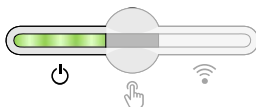

The inverter starts.

Flashing green

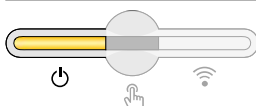

The inverter is in standby, is not operational (e.g. no feed-in at night) or is not configured.

Lights up yellow

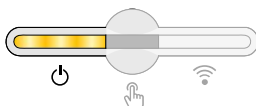

The inverter indicates a non-critical status.

Flashing yellow

| LED status indicator |   |
|----------------------|---|
|                      | The inverter indicates a critical status and there is no grid power feed process.<br>⏻ Lights up red                                |
|                      | The inverter indicates a backup power overload.<br>⏻ Flashing red   |
|                      | The network connection is being established via WPS.<br>2x 🖱️ = WPS search mode.<br>📶 Flashing green                                |
|                      | The network connection is being established via WLAN AP.<br>1x 🖱️ = WLAN AP search mode (active for 30 minutes).<br>📶 Flashing blue |
|                      | The network connection is not configured.<br>📶 Lights up yellow   |
|                      | The inverter is operating correctly, a network fault is indicated.<br>📶 Lights up red   |
|                      | The inverter is performing an update.<br>⏻ / 📶 Flashing blue  |

**Installation with the app**

The "Fronius Solar.start" app is needed for this installation method. Depending on the end device with which the installation will be carried out, download the app for the respective platform.



- 1 Start the installation in the app.
- 2 Select the product to which the connection should be established.
- 3 Open the access point by touching the sensor once 🖱️ → Communication LED: flashes blue.
- 4 Follow and complete the installation wizard in the individual sections.

- 5 Add system components in Solar.web and start up the PV system.

The network wizard and the product setup can be carried out independently of each other. A network connection is required for the Solar.web installation wizard.

### Installation using the web browser

#### WLAN:

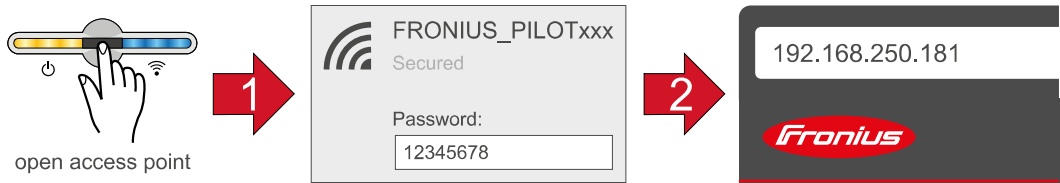

- 1 Open the access point by touching the sensor once → Communication LED: flashes blue.
- 2 Establish the connection to the inverter in the network settings (the inverter is displayed with the name "FRONIUS\_PILOT" and the serial number of the device).
- 3 Password: enter 12345678 and confirm.  
**IMPORTANT!**  
To enter the password on a Windows 10 operating system, the link "Connect using a security key instead" must first be activated to establish a connection with the password: 12345678.
- 4 In the browser address bar, enter and confirm the IP address 192.168.250.181. The installation wizard is opened.
- 5 Follow the installation wizard in the individual sections and complete the installation.
- 6 Add system components in Solar.web and start up the PV system.

The network wizard and the product setup can be carried out independently of each other. A network connection is required for the Solar.web installation wizard.

#### Ethernet:

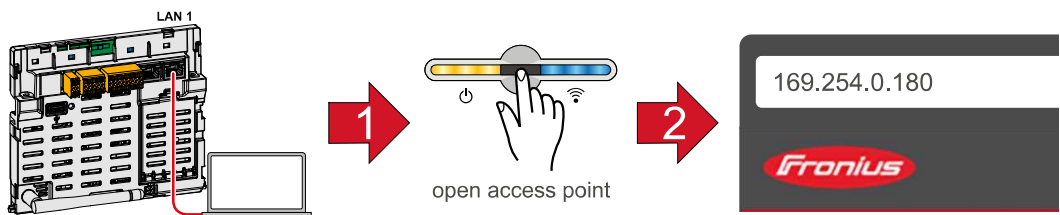

- 1 Establish a connection to the inverter (LAN1) with a network cable (CAT5 STP or higher).
- 2 Open the access point by touching the sensor once → Communication LED: flashes blue.
- 3 In the browser address bar, enter and confirm IP address 169.254.0.180. The installation wizard is opened.
- 4 Follow the installation wizard in the individual sections and complete the installation.
- 5 Add system components in Solar.web and start up the PV system.

The network wizard and the product setup can be carried out independently of each other. A network connection is required for the Solar.web installation wizard.

# Switching off current supply and restarting the inverter

De-energizing the inverter and switching it on again

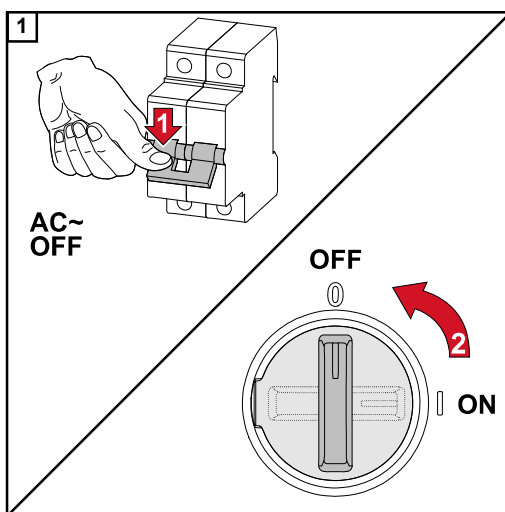

1. Turn off the automatic circuit breaker.
2. Turn the DC disconnecter to the "Off" switch position.

To start up the inverter again, follow the steps listed above in reverse order.

# **Settings - website of the inverter**

# User settings

---

## User login

- 1 Open the website of the inverter in your browser.
- 2 In the “Login” menu, log in using your user name and password, or go to the “User” menu and click on the “User login” button and then log in with your user name and password.

### **IMPORTANT!**

Depending on the user's authorization, settings can be executed in the individual menus.

---

## Selecting the language

- 1 In the “User” menu, click on the “Language” button and select the desired language.

# Device configuration

---

## Components

Select "Add component+" to add all available components to the system.

---

### PV generator

Activate the MPP tracker and enter the connected PV power in the associated field. For combined solar module strings, "PV 1 + PV 2 connected in parallel" must be activated.

---

### Battery

If the SoC mode is set to "Automatic", the values "Minimum SoC" and "Maximum SoC" are preset according to the technical specifications of the battery manufacturer.

If the SoC mode is set to "Manual", the values "Minimum SoC" and "Maximum SoC" may be changed after consultation with the battery manufacturer within the scope of their technical specifications. In the event of a power outage, the set values are not taken into account.

Using the "Allow battery charging from additional producers in home network" setting, charging of the battery from other external producers is enabled/disabled.

Using the "Allow battery charging from public grid" setting, charging of the battery from the public grid is enabled/disabled.

The normative or feed-in tariff rules must be taken into account with this setting. The setting does not affect the charging of the battery by other producers within the home. It merely relates to the process of drawing charging energy from the public grid. Regardless of this setting, any charging from the public grid that is required for service reasons (e.g. necessary re-charging to protect against deep discharge) is still performed.

### IMPORTANT!

Fronius accepts no liability for damage to third-party batteries.

---

### Primary meter

To ensure smooth operation in conjunction with other energy producers and in Full Backup backup power mode, it is important to install the Fronius Smart Meter at the feed-in point. The inverter and other producers must be connected to the public grid via the Fronius Smart Meter.

This setting also affects the behaviour of the inverter at night. If the function is deactivated, the inverter switches to Standby mode as soon as there is no more PV power available, provided that no energy management command is sent to the battery (e.g. minimum state of charge reached). The message "Power low" is displayed. The inverter restarts as soon as an energy management command is sent or sufficient PV power is available.

If the function is activated, the inverter remains permanently connected to the grid so that energy can be drawn from other producers at any time.

After connecting the meter, the position must be configured. A different Modbus address needs to be set for each Smart Meter.

The Watt value on the generator meter is the sum of all generator meters. The Watt value on the consumption meter is the value of all secondary meters.

---

### Ohmpilot

All Ohmpilots available in the system are displayed. Select the desired Ohmpilot and add it to the system via "Add".

---

## Functions and I/Os

### Backup power

"Off", "PV Point" or "Full Backup" can be selected for backup power mode.

Full Backup can only be activated once the required I/O assignments have been configured for backup power. In addition, a meter must be mounted and configured at the

feed-in point for Full Backup backup power mode.

### IMPORTANT!

When configuring "PV Point" backup power mode, the information in chapter [Safety](#) on page [73](#) must be observed.

When configuring "Full Backup" backup power mode, the information in chapter [Safety](#) on page [78](#) must be observed.

### Backup power nominal voltage

When backup power mode is activated, the nominal voltage of the public grid must be selected.

### State of charge warning limit

A warning is output when the residual capacity of the battery specified here is reached in backup power mode.

### Reserve capacity

The set value results in a residual capacity (depending on the capacity of the battery) that is reserved for backup power. The battery is not discharged below the residual capacity in grid-connected operation. In backup power mode, the manually set value "Minimum SoC" is not taken into account. If there is a power outage, the battery is always discharged down to the automatically preset minimum SoC in accordance with the technical specifications of the battery manufacturer.

### Load management

Up to four pins can be selected for load management here. Additional load management settings are available in the "Load management" menu item.

Default: Pin 1

### Australia - Demand Response Mode (DRM)

The pins for control via DRM can be set here:

| Mode | Description   | Information  | DRM pin                | I/O pin    |
|------|---|--|------------------------|------------|
| DRM0 | Inverter disconnects itself from the grid                     | DRM0 occurs if there is an interruption or short circuit on the REF GEN or COM LOAD leads, or if the combinations DRM1 - DRM8 are invalid.<br>The mains relays open. | REF GEN<br>COM<br>LOAD | IO4<br>IO5 |
| DRM1 | Import $P_{nom} \leq 0\%$ without disconnection from the grid | currently not supported  | DRM 1/5                | IN6        |
| DRM2 | Import $P_{nom} \leq 50\%$                                    | currently not supported  | DRM 2/6                | IN7        |
| DRM3 | Import $P_{nom} \leq 75\%$ & $+Q_{rel}^* \geq 0\%$            | currently not supported  | DRM 3/7                | IN8        |
| DRM4 | Import $P_{nom} \leq 100\%$                                   | currently not supported  | DRM 4/8                | IN9        |
| DRM5 | Export $P_{nom} \leq 0\%$ without disconnection from the grid | currently not supported  | DRM 1/5                | IN6        |
| DRM6 | Export $P_{nom} \leq 50\%$                                    | currently not supported  | DRM 2/6                | IN7        |
| DRM7 | Export $P_{nom} \leq 75\%$ & $-Q_{rel}^* \geq 0\%$            | currently not supported  | DRM 3/7                | IN8        |
| DRM8 | Export $P_{nom} \leq 100\%$                                   | currently not supported  | DRM 4/8                | IN9        |



| Mode | Description | Information | DRM pin | I/O pin |
|------|-------------|-------------|---------|---------|
|------|-------------|-------------|---------|---------|

The percentages always refer to the nominal device output.

### IMPORTANT!

If the Demand Response Mode (DRM) function is enabled and no DRM control is connected, the inverter switches to Standby mode.

### Demand Response Modes (DRM)

Here you can enter a value for the apparent power input and the apparent power output for the Australia country setup.

### Inverter

#### "Enforce Standby"

When the function is activated, the feed-in mode of the inverter is interrupted. This enables a powerless shutdown of the inverter and protects its components. When the inverter is restarted, the standby function is automatically deactivated.

#### "PV 1" and "PV 2"

| Parameter              | Range of values | Description   |
|------------------------|-----------------|---|
| "Mode"                 | Off             | The MPP tracker is deactivated.   |
|                        | Auto            | The inverter uses the voltage at which the max. possible power of the MPP tracker is possible.                                  |
|                        | Fix             | The MPP tracker uses the voltage defined in the "UDC fix".  |
| "UDC fix"              | 80 - 530 V      | The inverter uses the fixed preset voltage used at the MPP tracker.   |
| "Dynamic Peak Manager" | Off             | The function is deactivated.  |
|                        | On              | The entire solar module string is checked for optimisation potential and determines the best possible voltage for feed-in mode. |

#### "Ripple Control"

Ripple control signals are signals sent out by the energy company to switch controllable loads on and off. Depending on the installation situation, ripple control signals may be attenuated or amplified by the inverter. The settings below can be used to counteract this if necessary.

| Parameter                            | Range of values   | Description   |
|--------------------------------------|-------------------|---|
| "Reduction of Influence"             | Off               | The function is deactivated.  |
|                                      | On                | The function is activated.  |
| "Frequency of Ripple Control Signal" | 100 - 3000 Hz     | The frequency specified by the energy company must be entered here. |
| "Grid Inductance"                    | 0.00001 - 0.005 H | The value measured at the feed-in point must be entered here.       |

## "Measure against RCD false triggers"

(when using a 30 mA residual current circuit breaker)

### NOTE!

**National regulations, the grid operator's specifications or other factors may require a residual current circuit breaker in the AC connection lead.**

For this situation, a type A residual current circuit breaker is generally adequate. Nevertheless, false alarms can be triggered for the type A residual current circuit breaker in individual cases and depending on local conditions. For this reason, in accordance with national legislation, Fronius recommends that a residual current circuit breaker with a tripping current of at least 100 mA suitable for frequency converters be used.

| Parameter  | Range of values             | Description   |
|--|-----------------------------|---|
| "Switch-Off before 30mA RCD Trip" (only for Primo GEN24) | 0                           | No measures to prevent false tripping.  |
|  | 1                           | The inverter switches off at 15 mA before the residual current circuit breaker trips.   |
| "Leakage Current Factor" (only for Symo GEN24)           | 0 - 0.25<br>(default: 0.16) | Reducing the setting value reduces the leakage current and raises the intermediate circuit voltage, which slightly reduces the efficiency. Setting value 0.16 enables optimum efficiency. |

### "Iso Warning"

| Parameter                     | Range of values               | Description  |
|-------------------------------|-------------------------------|--|
| "Iso Warning"                 | Off                           | The isolation warning is deactivated.  |
|                               | On                            | The isolation warning is activated. A warning is issued in the event of an isolation fault.  |
| "Iso Alternative Mode"        | Accurate                      | Isolation monitoring is performed with the highest accuracy and the measured insulation resistance is displayed on the user interface of the inverter.   |
|                               | Fast                          | Isolation monitoring is performed with lower accuracy, which shortens the duration of the isolation measurement, and the isolation value is not displayed on the user interface of the inverter. |
| "Isolation Warning Threshold" | 100,000 - 10,000,000 $\Omega$ | If this threshold is undershot, status code 1083 is displayed on the user interface of the inverter.   |

### "Backup Power"

| Parameter                | Range of values | Description   |
|--------------------------|-----------------|---|
| "Backup Nominal Voltage" | 220 - 240 V     | Is the nominal phase voltage output in backup power mode. |

| Parameter                                      | Range of values | Description  |
|--|-----------------|--|
| "Backup Undervoltage Protection Limit U< [pu]" | 0 - 2%V         | The setting value is used to set the limit value for switching off backup power mode, e. g. setting value 0.9 = 90% of the nominal voltage.  |
| "Backup Undervoltage Protection Time U<"       | 0.04 - 20 s     | Triggering time for falling below the backup power undervoltage protection limit value.  |
| "Backup Overvoltage Protection Limit U> [pu]"  | 0 - 2%V         | The setting value is used to set the limit value for switching off backup power mode, e. g. setting value 1.1 = 110% of the nominal voltage.   |
| "Backup Overvoltage Protection Time U>"        | 0.04 - 20 s     | Triggering time for exceeding the backup power overvoltage protection limit value.   |
| "Backup Restart Delay"                         | 0 - 600 s       | Is the waiting time for resumption of backup power mode after a shutdown.  |
| "Backup Restart Attempts"                      | 1 - 10          | Is the max. number of automatic restart attempts. When the max. number of automatic restart attempts is reached, the service message 1177 must be acknowledged manually.   |
| "Backup External Frequency Check" (Italy only) | Off             | The function is deactivated  |
|  | On              | For backup power mode (Full Backup) in Italy, the external frequency check must be activated. Before ending backup power mode, the grid frequency is checked. When the grid frequency is in the allowed limit range, the loads are connected to the public grid. |
| "Backup Short Circuit Trip Time"               | 0.001 - 60 s    | If a short circuit occurs in backup power mode, this mode is interrupted within the set time.  |

# Energy management

## Energy management

### Self-consumption optimisation

The inverter always adjusts to the set target value on the Smart Meter. In the "automatic" operating mode (factory setting), an adjustment is made to 0 W at the feed-in point (maximum self-consumption).

The target value also applies if a further source feeds into this Smart Meter. However, in this case:

- The Fronius Smart Meter must be installed at the feed-in point
- Battery charging must be activated by another producer

The self-consumption optimisation has lower priority than the battery control specifications.

### Self-consumption optimization

Switch self-consumption optimization to automatic or manual.

### Target value on Smart Meter

If a manual selection is made under self-consumption optimisation, the target value on the Smart Meter and the reference/feed-in can be selected here.

---

**External producers** (only possible with active battery and inverter with battery connection)

If further decentralised producers are installed in the house, and these are incorporated into the self-consumption regulation of the Fronius Hybrid inverter, this setting must be activated. This means that energy can be drawn from the household network and fed into the battery via the Fronius GEN24 inverter. You can restrict how much power is consumed by the Fronius GEN24 inverter by specifying the maximum AC power (AC max.). A maximum power consumption of the AC rated power of the Fronius GEN24 inverter is possible.

## PV power reduction

The battery control specifications make the generated energy as optimally usable as possible. Situations may arise, however, in which PV energy cannot be used in full due to battery control specifications.

### Example

|                                   |                            |
|-----------------------------------|----------------------------|
| Fronius inverter                  | 6000 W (max. output power) |
| BYD Battery-Box Premium HVS / HVM |                            |
| defined discharge                 | 6000 W                     |
| PV power                          | 1000 W                     |

In this case, the inverter would have to reduce the PV power to 0 W, since the output power of the inverter is max. 6000 W and the device is already being used to capacity by the discharging.

Since it doesn't make sense to waste PV power, the power limit is automatically adjusted in the battery control specifications such that no PV power is wasted. In the example above, this means that the battery is discharged only at 5000 W, so that the 1000 W PV power can be used.

---

**Load management****Priorities**

If additional components (e.g. battery, Ohmpilot) are present in the system, the priorities can be set here. Devices having higher priority are actuated first, and subsequently, if there is still excess energy available, the other devices.

**Load management**

It is possible for up to four different load management rules to be defined. At the same threshold values, the rules are activated in succession. For deactivation, this is done in reverse; the I/O last switched on is the first to be switched off. In the case of different thresholds, the I/O with the lowest threshold is switched on first, followed by the second lowest, and so on.

I/Os controlled by the produced power are always prioritised over a battery and Ohmpilot. That is to say that an I/O can switch on and result in the battery no longer being charged or the Ohmpilot no longer being activated.

An I/O is activated or deactivated only after 60 seconds.

**Control**

- Control is deactivated.
- Control is effected by the power generated.
- Control is effected by excess power (given feed limits). This option can only be selected if a meter has been connected. Control via Energy Manager is effected using the actual power of feeding in with respect to the grid.

**Thresholds**

- On: For entering an effective power limit, at which the output is activated.
- Off: For entering an effective power limit, at which the output is deactivated.

**Runtimes**

- Field for enabling a minimum duration for which the output is to be activated for each switch-on process.
- Field for enabling the maximum runtime per day.
- Field for enabling a target duration for which the output is to be activated in total per day (total of several switch-on processes).

---

## General

### General settings

- 1 In the "System name" input field, enter the name of the system (max. 30 characters).
- 2 "Synchronize time automatically" enabled → select "Area time zone" and "Location time zone". The date and time are applied from the time zone entered.
- 2 "Synchronize time automatically" disabled → enter or select "Date", "Time", "Area time zone" and "Location time zone".
- 3 Click on the "Save" button.

---

## Update

All available updates are made available on the product page and in the "Download search" area under [www.fronius.com](http://www.fronius.com) .

### Firmware update

- 1 Drag the firmware file into the "Drag&Drop file here" field or select it using "Select file".

The update will start.

---

## Setup wizard

The guided setup wizard can be accessed here.

---

## Restoring the factory settings

### All settings

All configuration data is reset with the exception of the country setup. Changes to the country setup may only be carried out by authorized personnel.

---

### All settings with no network

All configuration data is reset with the exception of the country setup and the network settings. Changes to the country setup may only be carried out by authorized personnel.

---

## Event Log

### Current events

All current events of the connected system components are shown here.

### IMPORTANT!

Depending on the type of event, these must be confirmed via the "tick" button in order to be processed further.

---

### Archived

All events of the connected system components that no longer exist are shown here.

---

## Information

This menu displays all system information and the current settings.

---

### Save as PDF

- 1 Click on the "Save as PDF" button.
- 2 Individually select information with the "tick" next to the information or tick to "Select all".

- 3 Enter the file name in the input field and click on the "Save" button.

The PDF is created and displayed.

---

## Licence manager

The licence file contains the performance data and the scope of functions of the inverter. When replacing the inverter, power stage set or data communication area, the licence file must also be replaced.

### Licensing - online (recommended):

An Internet connection and completed configuration on Solar.web is required.

- 1 Complete the installation work (see chapter [Closing the inverter's connection area/housing cover, and commissioning](#) on page 89).
- 2 Connect to the website of the inverter.
- 3 Enter the serial number and verification code (VCode) of the defective and replacement unit. The serial number and the VCode can be found on the rating plate of the inverter (see chapter [Warning notices on the device](#) on page 47).
- 4 Click on the "Start online licensing" button.
- 5 Skip the Terms of use and Network settings menu items by clicking on "Next".

The licence activation starts.

### Licensing - offline:

There must be no Internet connection for this. When licensing offline with an established internet connection, the licence file is automatically uploaded to the inverter. Therefore, when uploading the licence file, the following error occurs: "The licence has already been installed and the wizard can be closed".

- 1 Complete the installation work (see chapter [Closing the inverter's connection area/housing cover, and commissioning](#) on page 89).
- 2 Connect to the website of the inverter.
- 3 Enter the serial number and verification code (VCode) of the defective and replacement unit. The serial number and the VCode can be found on the rating plate of the inverter (see chapter [Warning notices on the device](#) on page 47).
- 4 Click on the "Start offline licensing" button.
- 5 Download the service file onto the end device by clicking on the "Download service file" button.
- 6 Open the website [licensemanager.solarweb.com](http://licensemanager.solarweb.com) and log in with your user name and password.
- 7 Drag or upload the service file into the "Drop service file here or click to upload" field.
- 8 Download the newly generated licence file onto the end device using the "Download license file" button.
- 9 Go to the inverter website and drag the licence file into the "Drag&Drop licence file here" field, or select it via "Select license file".

The licence activation starts.

---

## Support

### Activate support user

- 1 Click the "Activate support user" button.

The support user is activated.

### IMPORTANT!

The support user only allows Fronius Technical Support to implement settings on the in-

verter via a secure connection. The button "End support user access" deactivates the access.

---

#### **Create support info** (for Fronius Support team)

- 1 Click on the "Create support info" button.
- 2 The sdp.cry file is downloaded automatically. To download manually, click on the "Download Support-Info" button.

The sdp.cry file is saved in the downloads.

---

#### **Enable remote maintenance**

- 1 Click on the "Enable remote maintenance" button.

Remote maintenance access for the Fronius Support team is enabled.

#### **IMPORTANT!**

Remote maintenance access gives Fronius Technical Support exclusive access to the inverter via a secure connection. Diagnostic data is transmitted here that can be used for troubleshooting purposes. Only enable remote maintenance access following a request from the Fronius Support team.



# Communication

---

## Network

### Server addresses for data transfer

If a firewall is used for outgoing connections, the following protocols, server addresses and ports must be allowed for successful data transfer:

- Tcp froniussseiot.azure-devices.net:8883
  - Tcp froniussseiot-telemetry.azure-devices.net:8883
  - Tcp froniussseiot-telemetry.azure-devices.net:443
  - Udp sera-gen24.fronius.com:1194 (213.33.117.120:1194)
  - Tcp froniussseiot.blob.core.windows.net:443
  - Tcp provisioning.solarweb.com:443
  - Tcp cure-se.fronius.com:443
- 

### LAN:

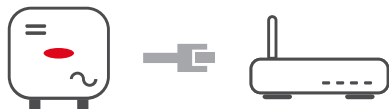

- 1 Enter host name.
- 2 Select connection type "automatic" or "static".
- 3 For connection type "static" - enter IP address, subnet mask, DNS and gateway.
- 4 Click on the "Connect" button.

The connection is established.

---

### WLAN:



Establishing a connection via WPS:

- 1 Click the "Enable" button.
- 2 Activate WPS on the WLAN router (see documentation provided with the WLAN router).

The connection is established automatically.

### Select and connect WLAN network:

The networks found are shown in the list. Clicking on the refresh button  will carry out a second search of the available WLAN networks. The "Find network" input field can be used to further restrict the selection list.

- 1 Select network from the list.
- 2 Select connection type "automatic" or "static".
- 3 For connection type "automatic" - enter WLAN password and host name.
- 4 For connection type "static" - enter IP address, subnet mask, DNS and gateway.
- 5 Click on the "Connect" button.

The connection is established.

---

**Access point:**

The inverter acts as the access point. A PC or smart device connects directly with the inverter. It is not possible to connect to the internet. The "Network name (SSID)" and "Network key (PSK)" can be assigned in this menu.

It is possible to operate a connection via WLAN and via access point simultaneously.

**Modbus****Modbus RTU interface 0 / 1**

If one of the two Modbus RTU interfaces is set to Slave, the following input fields are available:

**"Baud rate"**

The baud rate influences the transmission speed between the individual components connected in the system. When selecting the baud rate, ensure that it is the same at both the sending and receiving end.

**"Parity"**

The parity bit can be used to check the parity. It detects transmission errors. A parity bit can safeguard a specific number of bits. The value (0 or 1) of the parity bit must be calculated by the sender and is checked by the recipient using the same calculation. The parity bit can be calculated for even and odd parity.

**"SunSpec Model Type"**

Depending on the SunSpec model, there are two different settings.

**float:** SunSpec Inverter Model 111, 112, 113 or 211, 212, 213.

**int + SF:** SunSpec Inverter Model 101, 102, 103 or 201, 202, 203.

**"Meter address"**

The value entered is the identification number (Unit ID) assigned to the meter. Can be found on the user interface of the inverter in the Communication - Modbus menu.

Factory setting: 200

**"Inverter address"**

The value entered is the identification number (Unit ID) assigned to the inverter. Can be found on the user interface of the inverter in the Communication - Modbus menu.

Factory setting: 1

**Slave as Modbus TCP**

If the function "Slave as Modbus TCP" is activated, the following input fields are available:

**"Modbus port"**

Number of the TCP port that is to be used for Modbus communication.

**"SunSpec Model Type"**

Depending on the SunSpec model, there are two different settings.

**float:** SunSpec Inverter Model 111, 112, 113 or 211, 212, 213.

**int + SF:** SunSpec Inverter Model 101, 102, 103 or 201, 202, 203.

**"Meter address"**

The value entered is the identification number (Unit ID) assigned to the meter. Can be found on the user interface of the inverter in the Communication - Modbus menu.

Factory setting: 200

#### "Inverter address"

The value entered is the identification number (Unit ID) assigned to the inverter. Can be found on the user interface of the inverter in the Communication - Modbus menu.

Factory setting: This value is invariably defined as 1.

---

#### **Inverter control via Modbus**

If this option is activated, the inverter is controlled via Modbus.

Inverter control includes the following functions:

- On/Off
  - Power reduction
  - Specification of a constant power factor (cos phi)
  - Specification of a constant reactive power value
  - Battery control specifications with battery
- 

#### **Fronius Solar API**

The Fronius Solar API is an Ethernet-based, open JSON interface. When enabled, IOT devices on the local network can access inverter information without authentication. For security reasons, the interface is deactivated at the factory and should not be activated if it is not required for a third-party application (e.g. EV charger, smart home solutions, etc.).

For monitoring, Fronius recommends using Fronius Solar.web instead, which provides secure access to inverter status and production information.

When performing a firmware update to version 1.14.x, the setting (activated/deactivated) of the Fronius Solar API is adopted.

# Safety and grid requirements

## Country setup

The "Country setup" menu area is intended exclusively for installers/service technicians from authorised specialist companies. The access code must be requested from the national/international Fronius point of contact using an application form.

The selected country setup for the respective country contains preset parameters according to the nationally applicable standards and requirements. Depending on local grid conditions and the specifications of the energy provider, adjustments to the selected country setup may be necessary.

### CAUTION!

#### **Risk due to unauthorised access.**

Incorrectly set parameters can negatively influence the public grid and/or the feed-in of power into mains by the inverter, and lead to a loss of conformity with the standard.

- ▶ The parameters may only be adjusted by installers/service technicians from authorised specialist companies.
- ▶ Do not give the access code to third parties and/or unauthorised persons.

### CAUTION!

#### **Risk due to incorrectly set parameters.**

Incorrectly set parameters can negatively influence the public grid and/or cause faults and failures on the inverter, and lead to the loss of standard conformity.

- ▶ The parameters may only be adjusted by installers/service technicians from authorised specialist companies.
- ▶ The parameters may only be adjusted if the energy provider permits or requires this.
- ▶ Only adjust the parameters taking into account the nationally applicable standards and/or directives and the specifications of the energy provider.

## Feed-in limitation

Energy companies or grid operators may stipulate feed-in limitations for an inverter (e.g. max. 70% of kWp or max. 5 kW).

The feed-in limitation takes account of self-consumption by the household before the power of an inverter is reduced:

- A custom limit can be set.
- A Fronius Smart Meter can be connected to the Modbus push-in terminal of the data communication area at the connections M0/M1- / M0/M1+ for Modbus data.

With the inverter, any PV power that is not allowed to be fed into the public grid is used to charge the battery instead and/or used by the Fronius Ohmpilot so that it does not go to waste. The feed-in limitation is only active if the power fed in is higher than the set power reduction.

#### **"Off"**

The inverter converts the entire available PV power and feeds it into the public grid.

#### **"Limit for entire system"**

The entire PV system is limited in accordance with a set power limit. The value of the permissible total feed-in power must be set.

#### **"Total DC system power"**

Input field for the total DC system power in Wp.

This value is used if the "Maximum permitted feed-in power of the entire system" is specified in %.

**"Hard Limit"**

If this value is exceeded, the inverter switches off within max. 5 seconds. This value must be higher than the value set for "Soft Limit".

**"Soft Limit"**

If this value is exceeded, the inverter will regulate down to the set value within the time required by national standards and regulations.

**"Maximum permitted feed-in power of the entire system"**

Input field for the "Maximum permitted feed-in power of the entire system" in W or % (setting range: -10 to 100 %).

If there is no meter in the system or if a meter has failed, the inverter limits the feed-in power to the set value.

| <b>Example: Feed-in limitation</b><br>(without consideration of the efficiency)   |              |
|---|--------------|
| PV system to Fronius inverter:  | 5000 W       |
| Consumption in home:  | 1000 W       |
| Maximum permitted feed-in power of the entire system:   | 60% = 3000 W |
| <b>Case 1: The battery can be charged</b>   |              |
| Power at grid feed-in point:  | 0 W          |
| Power at inverter output:   | 1000 W       |
| Power into the battery:   | 3000 W       |
| <b>Case 2: The battery cannot be charged</b>  |              |
| Power at grid feed-in point   | 3000 W       |
| Power at inverter output:   | 4000 W       |
| Power into the battery:   | 0 W          |
| In this example, no more than 3000 W may be fed into the grid at the grid feed-in point. However, any loads that are located between the inverter and the grid feed-in point can be supplied by additional power from the inverter. These loads are also compensated as required. |              |

**Dynamic power regulation with several inverters**

**Example 1: Fronius SnapInverter ≤ Fronius Primo GEN24**

Only one primary meter is required for the Fronius Primo GEN24 inverter.

The power values shown are an example. Inverter configurations with power values other than those shown in the example are possible, taking into account the criteria for this example.

**IMPORTANT!**

Zero feed-in is not possible when using 2 inverters.

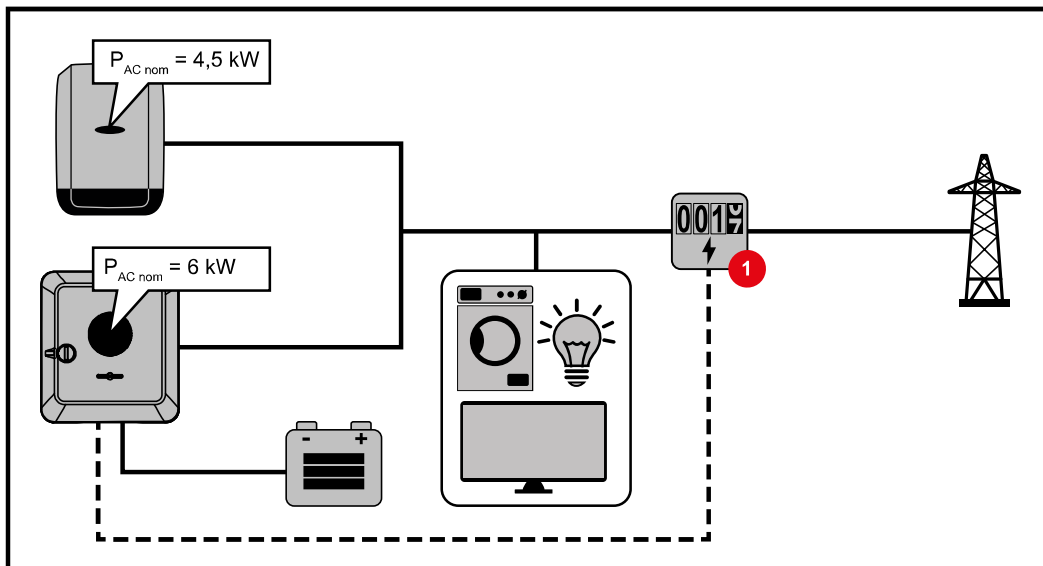

### Settings on the Fronius Primo GEN24 inverter website:

- 1 Configure the primary meter at the feed-in point in the "Device configuration" → "Components" menu area.
- 2 Activate the limit for the entire system in the "Safety and grid regulations" → "Export limitation" menu area. Enter the DC nominal output of the entire PV system in the "Total DC system power" input field. Enter the percentage value (50%, 60% or 70%) in the "Maximum permitted feed-in power of the entire system" input field.

### Example 2a: Fronius SnapINverter > Fronius Primo GEN24

Two primary meters are required for the inverters.

The power values shown are an example. Inverter configurations with power values other than those shown in the example are possible, taking into account the criteria for this example.

### IMPORTANT!

With two primary meters at the feed-in point without a secondary meter, Fronius SnapINverter and Fronius Primo GEN24 inverters cannot be displayed as a combined PV system in Solar.web. Two individual PV systems must be created in Solar.web.

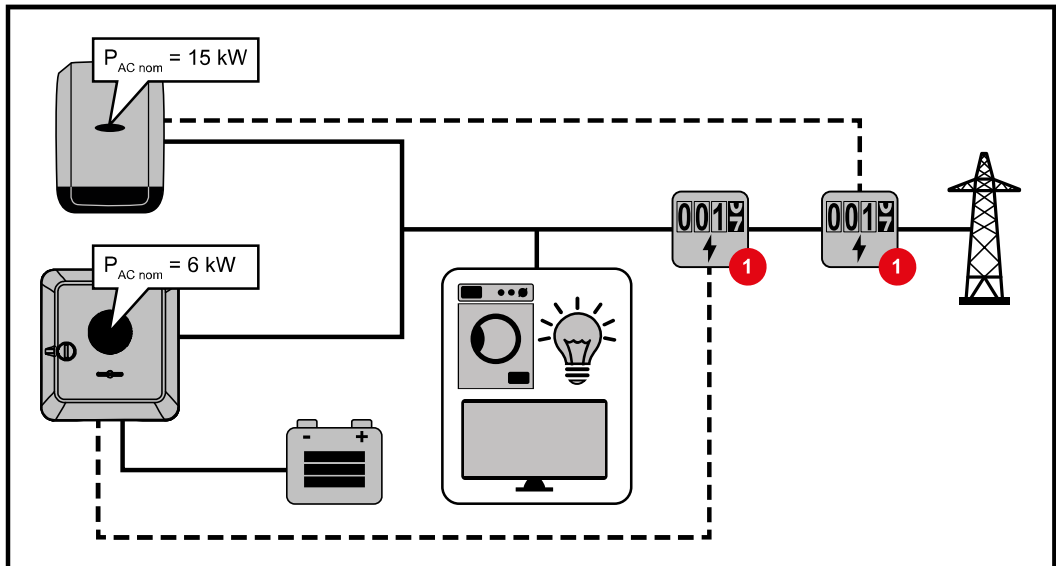

### Settings on the Fronius Primo GEN24 inverter website:

- 1 Configure the primary meter at the feed-in point in the "Device configuration" → "Components" menu area.

### Settings in the system monitoring of the Fronius SnapInverter:

- 1 Configure the primary meter at the feed-in point in the "Settings" → "Meter" menu area.
- 2 Activate the limit for the entire system in the "DNO Editor" → "Dynamic power reduction" menu area. Enter the DC nominal output of the entire PV system in the "Total DC system power" input field. Enter the percentage value (50%, 60% or 70%) in the "Max. grid feed-in power" input field.

---

### Example 2b: Fronius SnapInverter > Fronius Primo GEN24

Two primary meters and one secondary meter are required for the inverters.

The power values shown are an example. Inverter configurations with power values other than those shown in the example are possible, taking into account the criteria for this example.

### IMPORTANT!

In order to be able to record all PV system data in Solar.web in full, only the Fronius Primo GEN24 inverter may be created in this PV system. The Fronius SnapInverter data is transmitted from the secondary meter to the Fronius Primo GEN24 inverter and thus displayed in Solar.web.

We recommend that you set up the Fronius SnapInverter as a separate additional PV system in Solar.web for servicing and maintenance work (e.g. status codes, online updates, etc.).

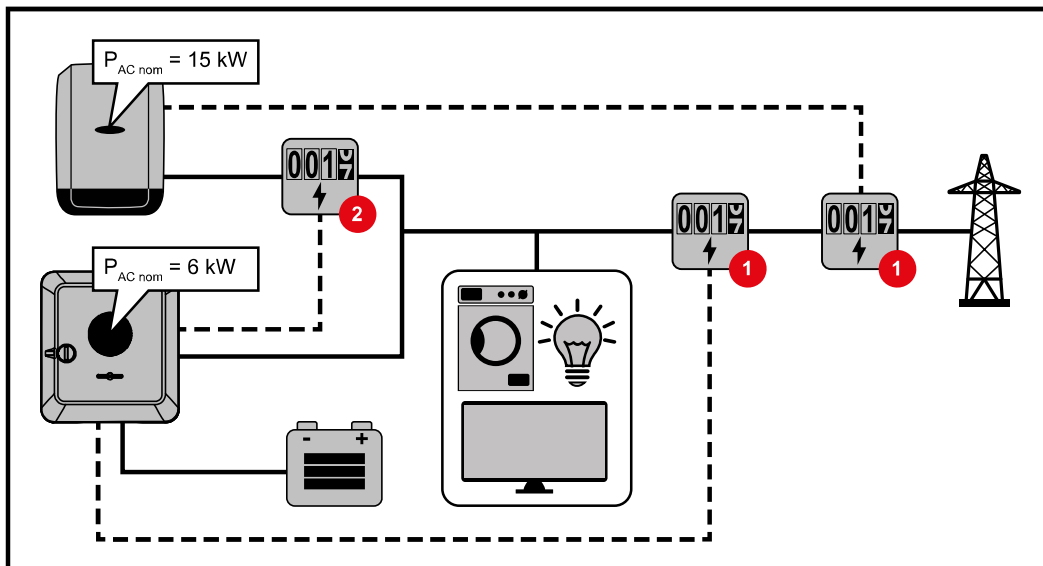

### Settings on the Fronius Primo GEN24 inverter website:

- 1 Configure the primary meter at the feed-in point in the "Device configuration" → "Components" menu area.
- 2 Configure the secondary meter in the "Device configuration" → "Components" menu area.

### Settings in the system monitoring of the Fronius SnapInverter:

- 1 Configure the primary meter at the feed-in point in the "Settings" → "Meter" menu area.
- 2 Activate the limit for the entire system in the "DNO Editor" → "Dynamic power reduction" menu area. Enter the DC nominal output of the entire PV system in the "Total DC system power" input field. Enter the percentage value (50%, 60% or 70%) in the "Max. grid feed-in power" input field.

## I/O power management

### General

In this menu item, settings relevant for an electricity company (DNO) are made. An effective power limitation in % and/or a power factor limitation can be set.

### IMPORTANT!

The service password must be entered in order to adjust settings in this menu item. Settings in this menu area must only be made by trained and qualified personnel.

### "Input pattern" (assignment of individual I/Os)

- 1 click = white (contact open)
- 2 clicks = blue (contact closed)
- 3 x clicks = grey (not used)

### "Power factor (cos φ)"

- "ind" = inductive
- "cap" = capacitive

### "DNO feedback"

when the rule is enabled, output "DNO feedback" (pin 1 recommended) must be configured (e.g. for operating a signalling device).

For "Import" or "Export", the data format \*.fpc is supported.



### Control priorities

For setting the control priorities for the ripple control signal receiver, the feed-in limitation and control via Modbus.

1 = highest priority, 3 = lowest priority

### Connection diagram - 4 relays

The ripple control signal receiver and the I/Os terminal of the inverter can be connected to one another in accordance with the connection diagram.

If the distance between the inverter and the ripple control signal receiver exceeds 10 m, at least a CAT 5 cable is recommended and the shield must be connected at one end to the push-in terminal of the data communication area (SHIELD).

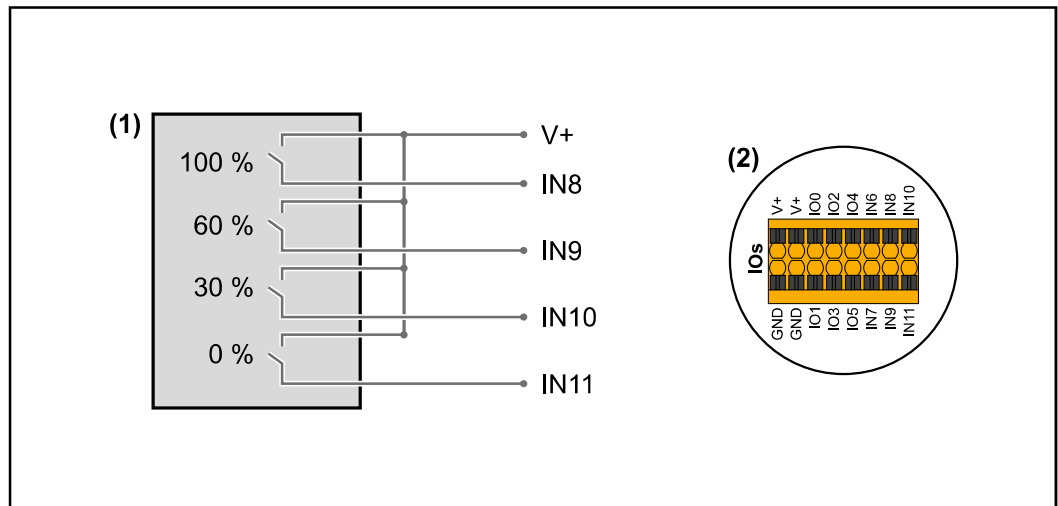

- (1) Ripple control signal receiver with 4 relays, for effective power limitation.
- (2) I/Os of the data communication area.

### Use the preconfigured file for 4-relay mode:

- 1 Download the file (.fpc) **under 4-relay mode** onto the end device.
- 2 Upload the file (.fpc) in the "I/O Power Management" menu using the "Import" button.
- 3 Click on the "Save" button.

The settings for 4-relay mode are stored.

# I/O power management settings - 4 relays

## I/O Power Management

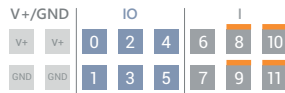

DNO Feedback  
not used

### DNO Rules

**Rule 1**

IO selection: 0, 2, 4, 6, 8, 10, 1, 3, 5, 7, 9, 11

Active Power: 100

Power Factor (cos φ): 1, cap

DNO Feedback:

**Rule 2**

IO selection: 0, 2, 4, 6, 8, 10, 1, 3, 5, 7, 9, 11

Active Power: 60

Power Factor (cos φ): 1, cap

DNO Feedback:

**Rule 3**

IO selection: 0, 2, 4, 6, 8, 10, 1, 3, 5, 7, 9, 11

Active Power: 30

Power Factor (cos φ): 1, cap

DNO Feedback:

**Rule 4**

IO selection: 0, 2, 4, 6, 8, 10, 1, 3, 5, 7, 9, 11

Active Power: 0

Power Factor (cos φ): 1, cap

DNO Feedback:

- 0 None
- 1 None
- 2 None
- 3 None
- 4 None
- 5 None
- 6 None
- 7 None
- 8 IO control
- 9 IO control
- 10 IO control
- 11 IO control

IMPORT EXPORT

## Connection diagram - 3 relays

The ripple control signal receiver and the I/Os terminal of the inverter can be connected to one another in accordance with the connection diagram.

If the distance between the inverter and the ripple control signal receiver exceeds 10 m, at least a CAT 5 cable is recommended and the shield must be connected at one end to the push-in terminal of the data communication area (SHIELD).

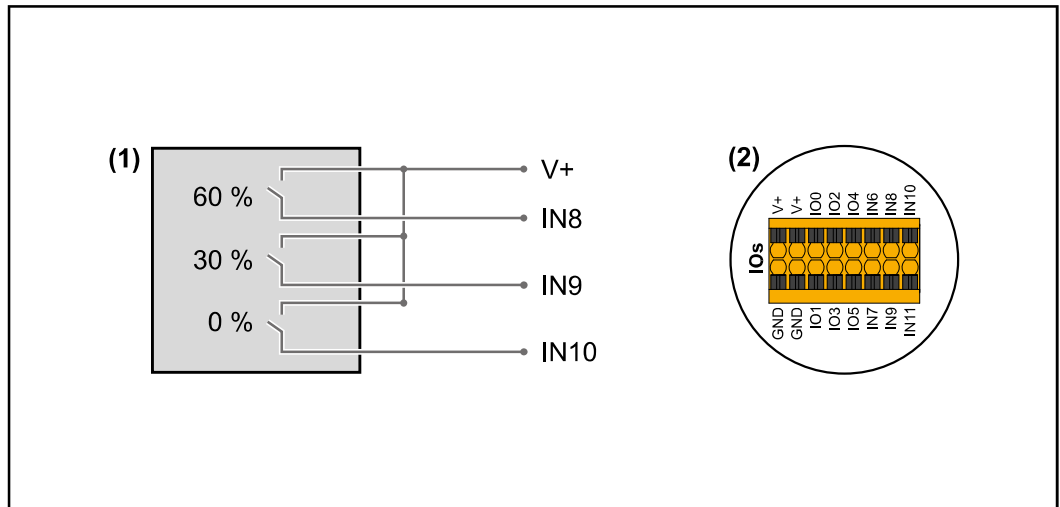

(1) Ripple control signal receiver with 3 relays, for effective power limiting.

(2) I/Os of the data communication area.

### Use the preconfigured file for 3-relay mode:

- 1 Download the file (.fpc) **under 3-relay mode** onto the end device.
- 2 Upload the file (.fpc) in the "I/O Power Management" menu using the "Import" button.
- 3 Click on the "Save" button.

The settings for 3-relay mode are stored.

# I/O power management settings - 3 relays

## I/O Power Management

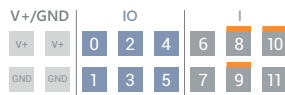

DNO Feedback  
not used

### DNO Rules

**Rule 1**

IO selection: 0, 2, 4, 6, 8, 10, 1, 3, 5, 7, 9, 11

Active Power: 100

Power Factor (cos φ): 1, cap

DNO Feedback:

**Rule 2**

IO selection: 0, 2, 4, 6, 8, 10, 1, 3, 5, 7, 9, 11

Active Power: 60

Power Factor (cos φ): 1, cap

DNO Feedback:

**Rule 3**

IO selection: 0, 2, 4, 6, 8, 10, 1, 3, 5, 7, 9, 11

Active Power: 30

Power Factor (cos φ): 1, cap

DNO Feedback:

**Rule 4**

IO selection: 0, 2, 4, 6, 8, 10, 1, 3, 5, 7, 9, 11

Active Power: 0

Power Factor (cos φ): 1, cap

DNO Feedback:

- 0 None
- 1 None
- 2 None
- 3 None
- 4 None
- 5 None
- 6 None
- 7 None
- 8 IO control
- 9 IO control
- 10 IO control
- 11 None

## Connection diagram - 2 relays

The ripple control signal receiver and the I/Os terminal of the inverter can be connected to one another in accordance with the connection diagram.

If the distance between the inverter and the ripple control signal receiver exceeds 10 m, at least a CAT 5 cable is recommended and the shield must be connected at one end to the push-in terminal of the data communication area (SHIELD).

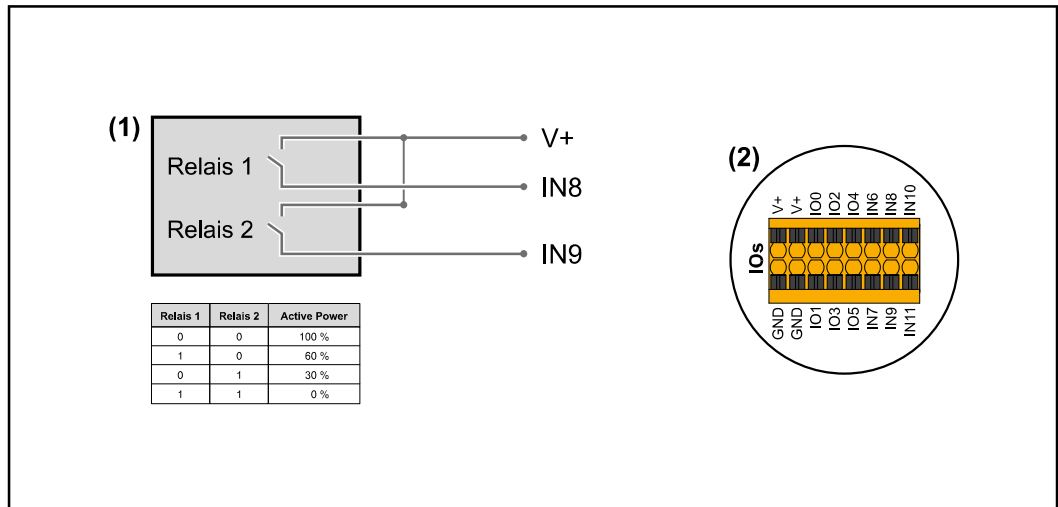

(1) Ripple control signal receiver with 2 relays, for effective power limitation.

(2) I/Os of the data communication area.

### Use the preconfigured file for 2-relay mode:

- 1 Download the file (.fpc) **under 2-relay mode** onto the end device.
- 2 Upload the file (.fpc) in the "I/O Power Management" menu using the "Import" button.
- 3 Click on the "Save" button.

The settings for 2-relay mode are stored.

I/O power management settings  
- 2 relays

## I/O Power Management

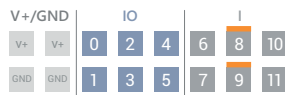

DNO Feedback  
not used

### DNO Rules

**Rule 1**

|   |   |   |   |   |    |
|---|---|---|---|---|----|
| 0 | 2 | 4 | 6 | 8 | 10 |
| 1 | 3 | 5 | 7 | 9 | 11 |

Active Power:  100

Power Factor (cos φ):  1 cap

DNO Feedback

**Rule 2**

|   |   |   |   |   |    |
|---|---|---|---|---|----|
| 0 | 2 | 4 | 6 | 8 | 10 |
| 1 | 3 | 5 | 7 | 9 | 11 |

Active Power:  60

Power Factor (cos φ):  1 cap

DNO Feedback

**Rule 3**

|   |   |   |   |   |    |
|---|---|---|---|---|----|
| 0 | 2 | 4 | 6 | 8 | 10 |
| 1 | 3 | 5 | 7 | 9 | 11 |

Active Power:  30

Power Factor (cos φ):  1 cap

DNO Feedback

**Rule 4**

|   |   |   |   |   |    |
|---|---|---|---|---|----|
| 0 | 2 | 4 | 6 | 8 | 10 |
| 1 | 3 | 5 | 7 | 9 | 11 |

Active Power:  0

Power Factor (cos φ):  1 cap

DNO Feedback

- 0 None
- 1 None
- 2 None
- 3 None
- 4 None
- 5 None
- 6 None
- 7 None
- 8 **IO control**
- 9 **IO control**
- 10 None
- 11 None

## Connection diagram - 1 relay

The ripple control signal receiver and the I/Os terminal of the inverter can be connected to one another in accordance with the connection diagram.

If the distance between the inverter and the ripple control signal receiver exceeds 10 m, at least a CAT 5 cable is recommended and the shield must be connected at one end to the push-in terminal of the data communication area (SHIELD).

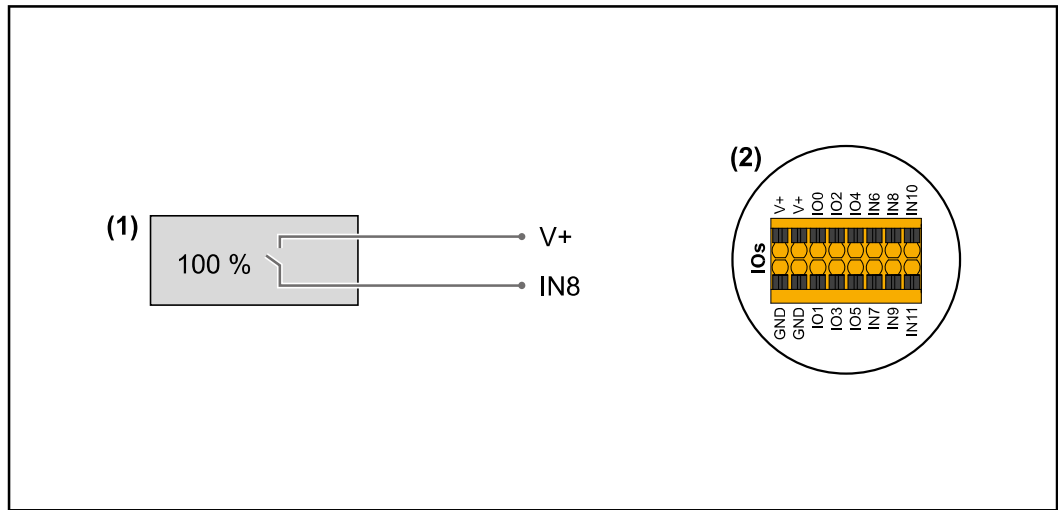

- (1) Ripple control signal receiver with 1 relay, for effective power limiting.
- (2) I/Os of the data communication area.

### Use the preconfigured file for 1-relay mode:

- 1 Download the file (.fpc) **under 1-relay mode** onto the end device.
- 2 Upload the file (.fpc) in the "I/O Power Management" menu using the "Import" button.
- 3 Click on the "Save" button.

The settings for 1-relay mode are stored.

**I/O power management settings - 1 relay**

**I/O Power Management**

**Autotest (CEI 0-21)**

**Description**

The 'Autotest' can be used to check the protective function required by the Italian standard for monitoring the voltage and frequency limits as well as the trip limits of the inverter during commissioning. During normal operation, the inverter constantly checks the current voltage and frequency actual value of the grid.

After the start of the autotest, various individual tests run automatically one after the other. Depending on grid conditions, the duration of the test is approx. 15 minutes.

**IMPORTANT!**

The inverter may only be commissioned in Italy after a successful autotest (CEI 0-21). If the autotest is not passed, no feed-in operation may take place. If the autotest is started once, it must be completed successfully. The autotest cannot be started during emergency power mode.

|                     |   |
|---------------------|---|
| VAC inner limit max | Test to check the maximum voltage in the phases |
| VAC inner limit min | Test to check the minimum voltage in the phases |
| FAC inner limit max | Test to check the maximum frequency             |



|                                 |  |
|---------------------------------|--|
| FAC inner limit min             | Test to check the minimum frequency                    |
| FAC alternative inner limit max | Test to check the maximum alternative frequency        |
| FAC alternative inner limit min | Test to check the minimum alternative frequency        |
| VAC outer limit min             | Test to check the minimum voltage in the phases        |
| VAC long time limit             | Test to check the 10 min average voltage in the phases |

### Save as PDF

- 1 Click the 'Save as PDF' button.
- 2 Enter the file name in the input field and click on the 'Print' button.

The PDF is created and displayed.

### Note on autotest

The limit values are set in the menu area 'Grid Code'.

The access code for the 'Grid Code' menu area corresponds to the installer code (PROFI menu) and is only made available to Fronius following a written request. An appropriate application form is available from national technical support.

# Options

# Surge protective device (SPD)

## General

A surge protective device (SPD) protects against temporary overvoltages and dissipates surge currents (e.g. lightning strike). Building on an overall lightning protection concept, the SPD helps to protect your PV system components.

For detailed information on the wiring diagram of the surge protective device, see chapter [Wiring diagram - surge protective device SPD](#) on page 176.

If the surge protective device is triggered, the colour of the indicator changes from green to red (mechanical display) and the operation LED of the inverter lights up red (see chapter [Button functions and LED status indicator](#) on page 90). The error code "1030 WSD Open " is displayed on the inverter's website in the System " → " Event Log " menu or in the user menu under "Notifications as well as in Fronius Solar.web. In this case, the inverter must be repaired by an authorised specialist.

### IMPORTANT!

The inverter also switches off if the 2-pin signal cable of the surge protective device is interrupted or damaged.

## Scope of supply

The surge protective device (SPD) is an optional extra and can be retrofitted to the inverter.

For technical data, see chapter "[Technical data](#)" on page 145.

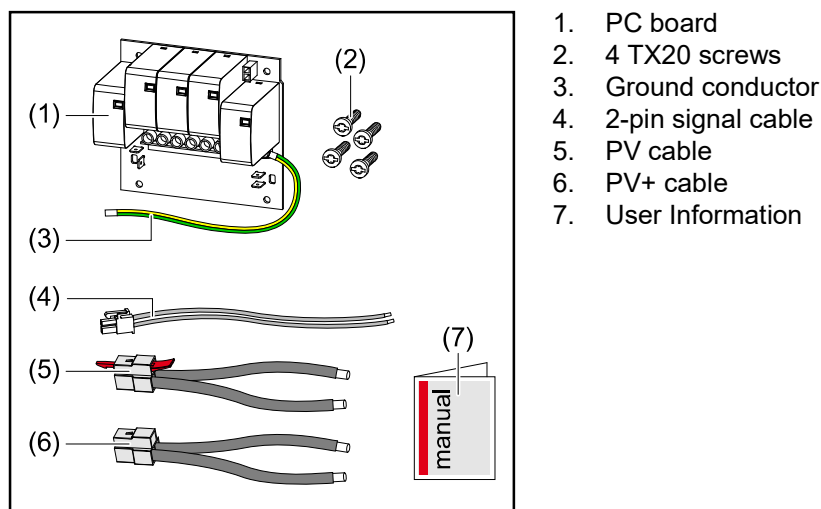

## De-energising the inverter



### WARNING!

#### Danger due to electrical voltage on live parts of the PV system.

An electric shock can be fatal.

- ▶ Disconnect live parts of the PV system on all pins and on all sides.
- ▶ Secure against re-activation in accordance with national regulations.
- ▶ Allow the capacitors of the inverter to discharge (2 minutes).
- ▶ Check that the inverter is de-energised with a suitable measuring device.



## WARNING!

### Danger due to work that has been carried out incorrectly.

This can result in serious injury and damage to property.

- ▶ Installing and connecting a surge protective device (SPD) must only be carried out by service personnel trained by Fronius and only within the scope of the respective technical regulations.
- ▶ Follow the safety rules.

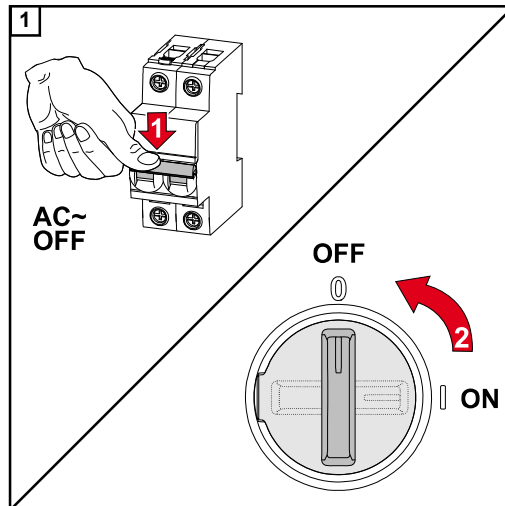

Turn off the automatic circuit breaker. Set the DC disconnecter to the "Off" switch position.

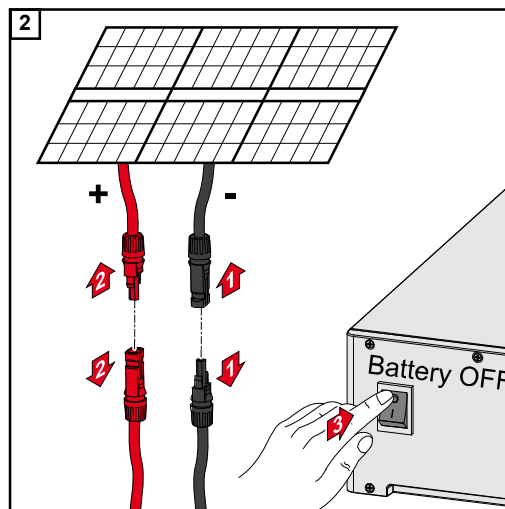

Disconnect connections from the solar module strings (+/-). Switch off the battery connected to the inverter.

Wait for the capacitors of the inverter to discharge (2 minutes).

## Installation



## CAUTION!

### Risk due to insufficiently dimensioned ground conductor.

Damage to the inverter due to thermal overload can result.

- ▶ The national standards and guidelines must be observed for dimensioning the ground conductor.

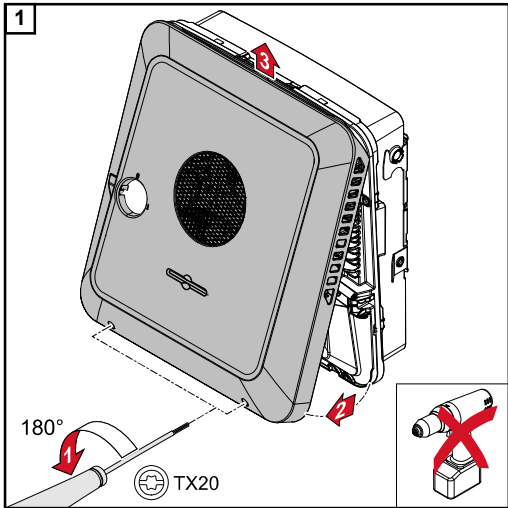

Loosen the two screws on the underside of the housing cover by rotating them 180° to the left using a screwdriver (TX20). Then lift the housing cover away from the inverter at the bottom and detach from above.

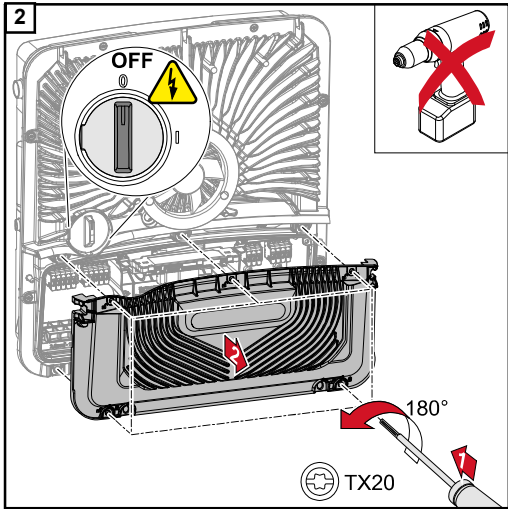

Loosen the five screws of the connection area cover by rotating them 180° to the left using a screwdriver (TX20). Remove the connection area cover from the device.

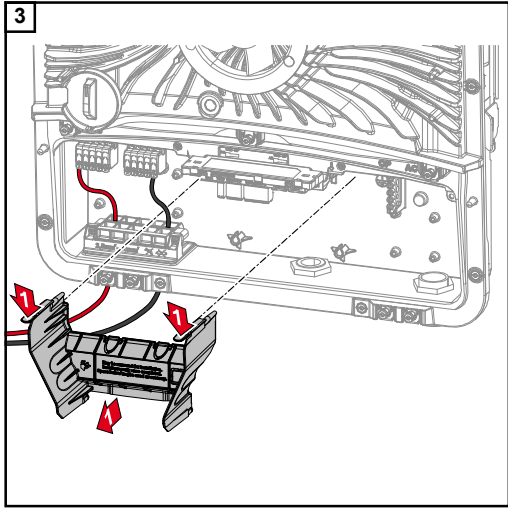

Remove the connection area divider by pressing the snap tabs.

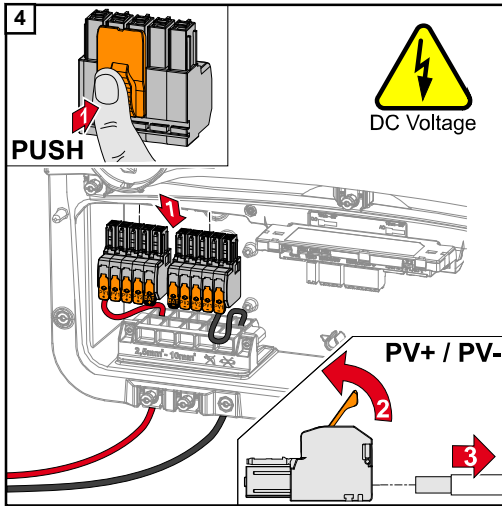

Remove the DC push-in terminals from the slots and disconnect them from the cables (only necessary if the installation already exists).

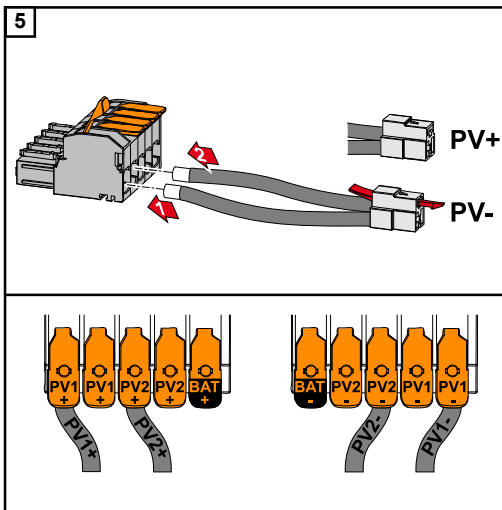

Connect the supplied PV+/PV- cables to the respective connections.

**IMPORTANT!**  
Note the labelling of the cables when connecting.

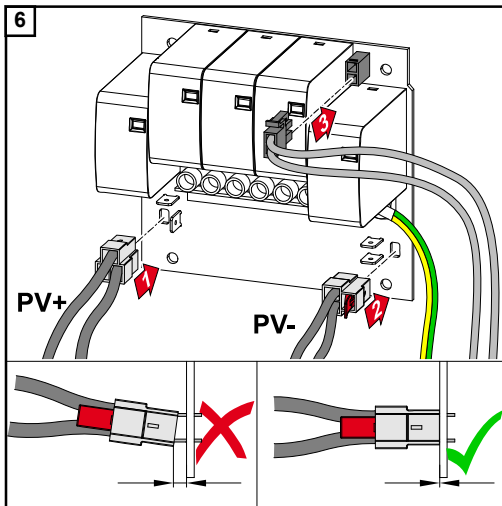

Connect the supplied cables to the respective connectors on the PC board.

**IMPORTANT!**  
The plugs must be connected onto the PC board as far as they will go.

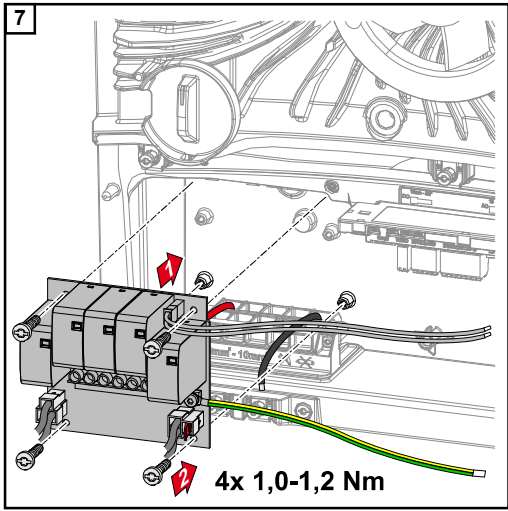

Insert the PC board into the inverter and secure with the four screws (TX20) supplied at a torque of 1.0 - 1.2 Nm.

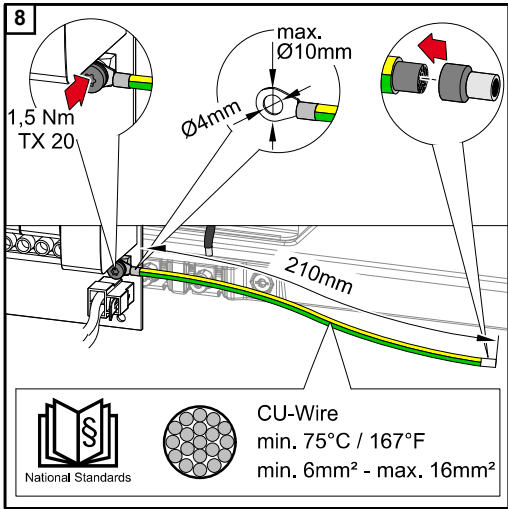

**IMPORTANT!**  
Depending on national standards and guidelines, a larger cross section of the ground conductor may be required.

Dimension the cable cross section of the ground conductor according to the national standards and guidelines and fit a ring cable lug (inner diameter: 4 mm, outer diameter: max. 10 mm) as well as a corresponding ferrule. Fasten the ground conductor to the PC board with a torque of 1.5 Nm.

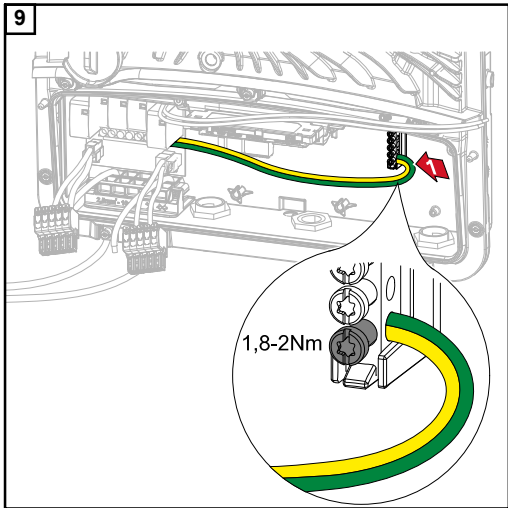

Fasten the ground conductor to the first input from the bottom of the ground electrode terminal using a screwdriver (TX20) and a torque of 1.8 - 2 Nm.

**IMPORTANT!**  
The use of other inputs can make it difficult to insert the connection area divider or damage the ground conductor.

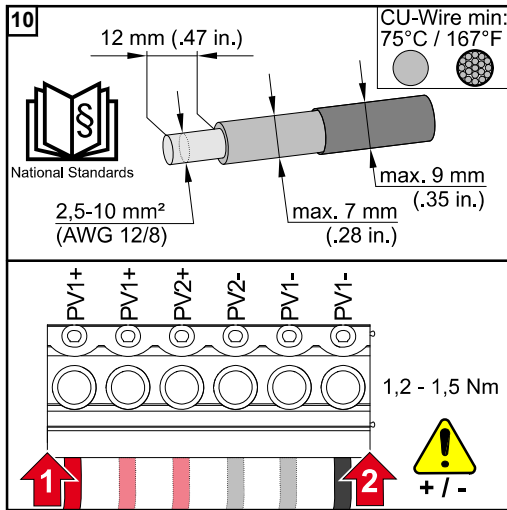

Strip the insulation on the single conductors by 12 mm and secure to the corresponding slot of the terminal on the PC board with a torque of 1.2 - 1.5 Nm.

**IMPORTANT!**

The cable cross-section must be selected according to the specifications for the respective inverter power category (see chapter **Permitted cables** on page 57).

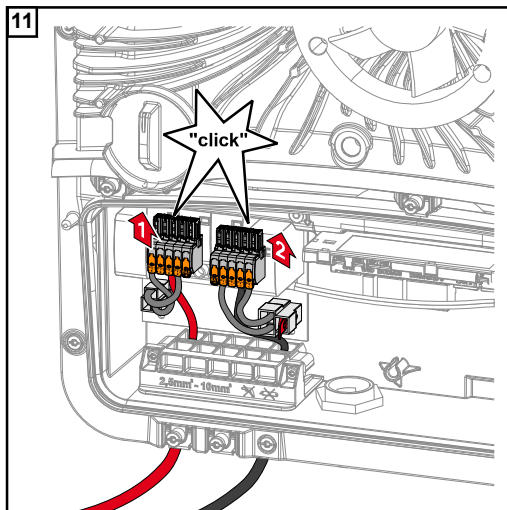

Push the DC push-in terminals into the corresponding slot until there is an audible click.

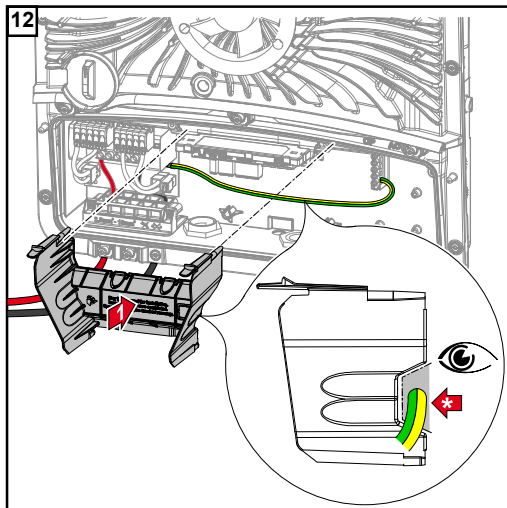

Re-insert the connection area divider.

\* Lay the ground conductor in the integrated cable duct.

**IMPORTANT!**

When inserting the connection area divider, be careful not to kink, pinch, crush or otherwise damage the ground conductor.



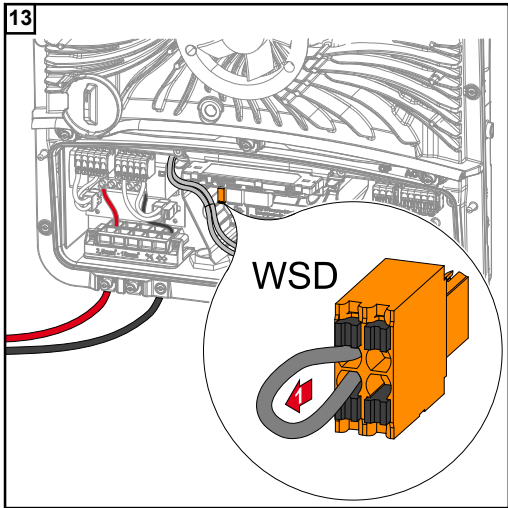

Remove the factory installed bypass on the push-in WSD terminal.

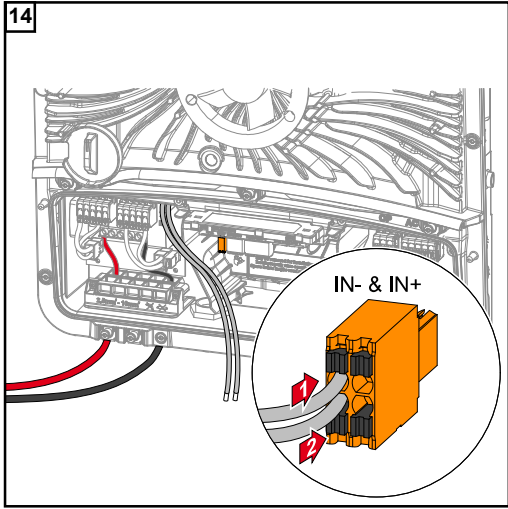

Connect the signal cable to the push-in WSD terminal on the IN- and IN+ slots, observing the labelling.

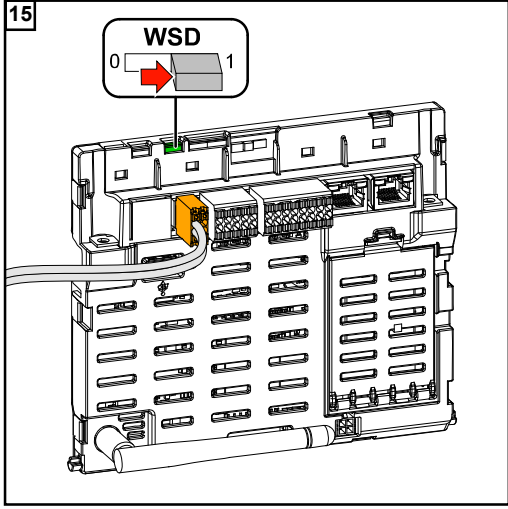

Check whether the WSD switch is in position 1, adjust if necessary (factory setting: position 1).

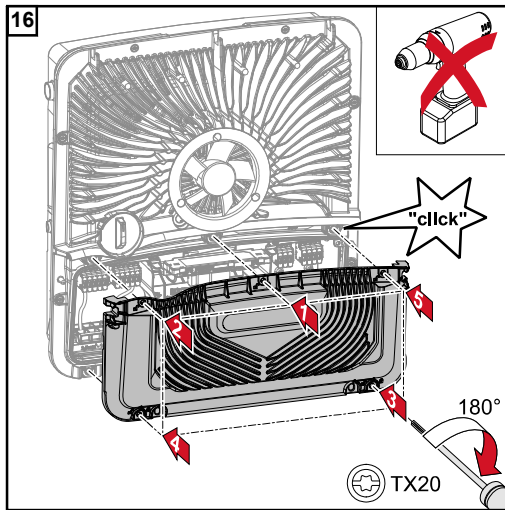

Place the cover on the connection area. Tighten the five screws by rotating them 180° to the right in the indicated order using a screwdriver (TX20).

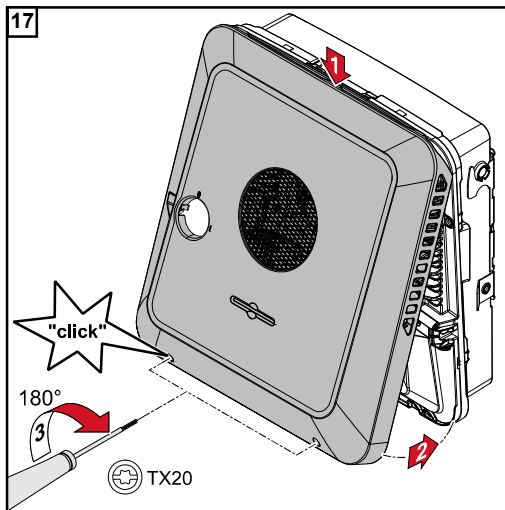

Clip the housing cover onto the inverter from above. Press on the lower part of the housing cover and tighten the two screws by rotating them 180° to the right using a screwdriver (TX20).

### Commissioning the inverter

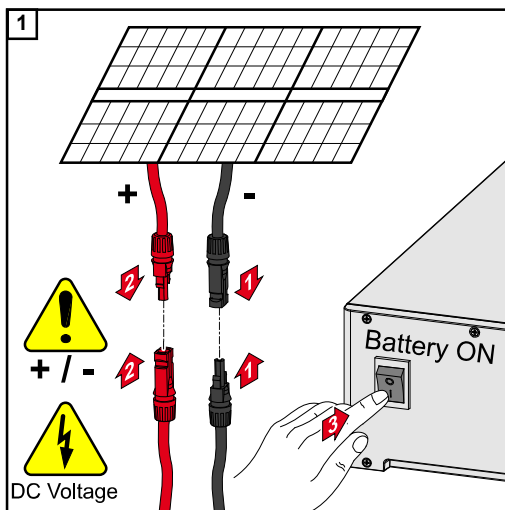

Connect the solar module strings (+/-). Switch on the battery connected to the inverter.

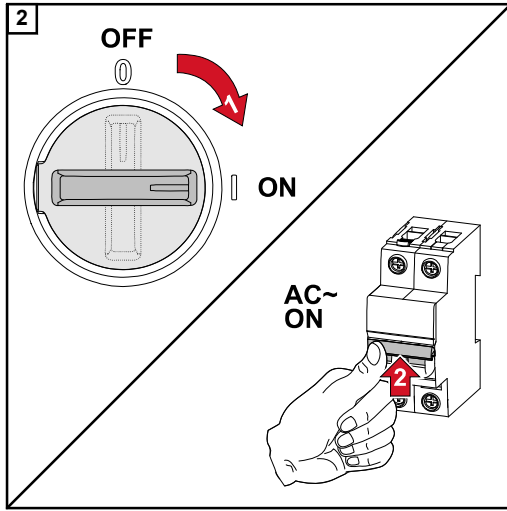

Set the DC disconnecter to the "On" switch position. Switch on the automatic circuit breaker.

# Appendix

# Care, maintenance and disposal

---

**General** The inverter is designed in such a way that no additional maintenance work builds up. Nevertheless, a few points must be considered during operation to ensure that the inverter works perfectly.

---

**Cleaning** Clean the inverter as required with a damp cloth.  
Do not use cleaning agents, abrasives solvents or similar to clean the inverter.

---

**Maintenance** Maintenance and servicing may only be carried out by Fronius-trained service technicians.

---

**Safety** The DC disconnect is used only to switch off power to the power stage set. When the DC disconnect is turned off, the connection area is still energized.

 **WARNING!**

**Danger from grid voltage and DC voltage from solar modules.**

An electric shock can be fatal.

- ▶ The connection area must only be opened by an authorised electrician.
  - ▶ The separate power stage set area must only be opened by Fronius-trained service technicians.
  - ▶ Prior to any connection work, disconnect the inverter on the AC side and the DC side.
- 

 **WARNING!**

**Danger of residual voltage from capacitors.**

An electric shock can be fatal.

- ▶ Allow the capacitors of the inverter to discharge (2 minutes).
- 

**Operation in dusty environments**

**NOTE!**

**If the inverter is operated in dusty environments, dirt may build up on the heat sink and fan.**

This may result in a loss of power due to insufficient cooling of the inverter.

- ▶ Make sure that the ambient air can always flow through the inverter's ventilation slots unimpeded.
  - ▶ Remove any build-ups of dirt from the heat sink and the fan.
-

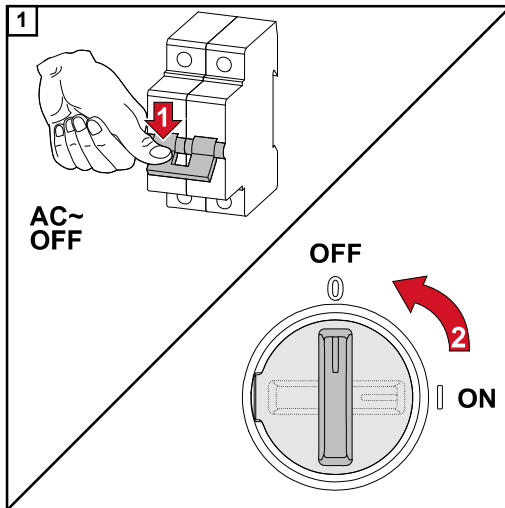

Switch off power to the inverter and wait for the specified time until the capacitors have discharged and the fan has shut down.  
Turn the DC disconnect to the "Off" switch position.

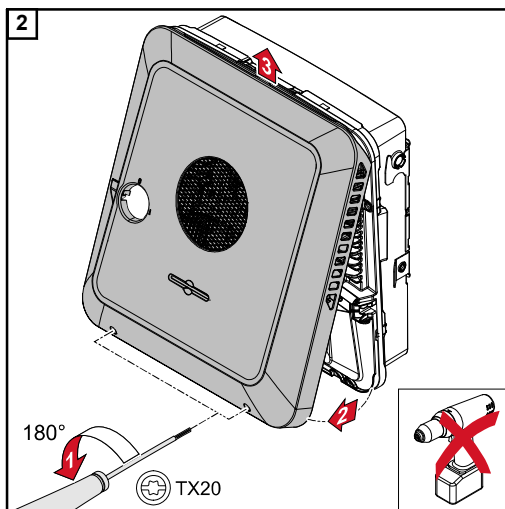

Loosen the screws on the underside of the housing cover by rotating them 180° to the left using a screwdriver (TX20). Then lift the housing cover away from the inverter at the bottom and detach upwards.

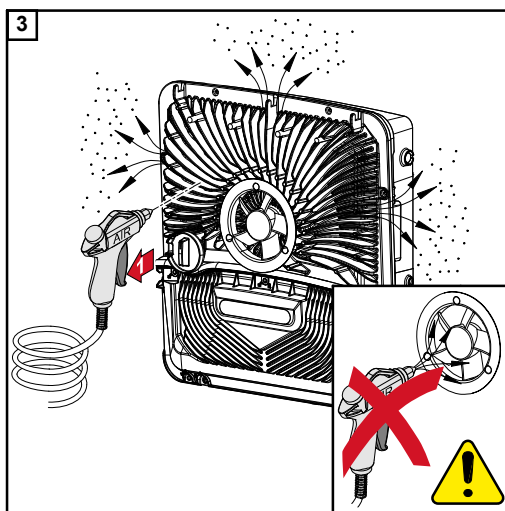

Remove any build-up of dirt on the heat sink and fan using compressed air, a cloth or a brush.

**NOTE!**

**Risk due to damage to the fan bearing from improper cleaning.**

Excessive speed and pressure on the fan bearing can cause damage.

- ▶ Block the fan and clean it with compressed air.
- ▶ When using a cloth or brush, clean the fan without applying pressure to the fan.

To start up the inverter again, follow the steps listed above in reverse order.

**Disposal**

Waste electrical and electronic equipment must be collected separately and recycled in an environmentally responsible manner in accordance with the European Directive and national law. Used equipment must be returned to the distributor or through a local, authorised collection and disposal system. Proper disposal of the old device promotes sustainable recycling of material resources. Ignoring this may lead to potential health/environmental impacts.

# Components for automatic Full Backup backup power changeover

## Components for automatic Full Backup backup power changeover

| Device name                    | Current converter | Item number  |
|--------------------------------|-------------------|--------------|
| Fronius Smart Meter 63A-1      | ✗                 | 43,0001,1477 |
| Fronius Smart Meter 50kA-3     | ✓                 | 43,0001,1478 |
| Fronius Smart Meter TS 100A-1  | ✗                 | 43,0001,0045 |
| Fronius Smart Meter TS 5kA-3   | ✓                 | 43,0001,0046 |
| Fronius Smart Meter 240 V-3 UL | ✓                 | 43,0001,3529 |

### Grid and system protection unit (fuse protection: 1-pin, 6 A)

Other manufacturers and types are permissible if they are technically and functionally identical to the examples below:

- VMD460-NA-D-2 (Bender GmbH & Co. KG)
- RE-NA003-M64 (Tele Haase Steuergeräte Ges.m.b.H.)

| K1 and K2 - installation contactor with auxiliary contact |  |
|---|--|
| Number of pins  | 1-pin or 2-pin<br>(depending on the cabling variant) |
| Rated current   | depending on house connection                        |
| Coil voltage  | 230 V AC   |
| Rated frequency   | 50/60 Hz   |
| Coil fuse   | 6 A  |
| Min. short circuit current                                | 3 kA (make contacts)                                 |
| Test standard   | IEC 60947-4-1  |
| Auxiliary contact   |  |
| Number of NC contacts                                     | 1  |
| Switching voltage   | 12-230 V @ 50/60 Hz                                  |
| Min. nominal current                                      | 1 A  |
| Min. short circuit current                                | 1 kA   |
| Examples of contactors and relays                         | ISKRA IK63-40 / Schrack BZ326461                     |

| K3 - modular relay                |  |
|-----------------------------------|--|
| Number of changeover contacts     | 2  |
| Coil voltage                      | 12 V DC  |
| Test standard                     | IEC 60947-4-1  |
| Examples of contactors and relays | Finder 22.23.9.012.4000 / Schrack relay RT424012 (bracket RT17017, relay base RT78725) |

| <b>K4 and K5 - installation contactor</b> |                      |
|---|----------------------|
| Number of NC contacts                     | 2 (25 A)             |
| Coil voltage                              | 230 V AC (2P)        |
| Rated frequency                           | 50/60 Hz             |
| Coil fuse                                 | 6 A                  |
| Min. short circuit current                | 3 kA (make contacts) |
| Test standard                             | IEC 60947-4-1        |
| Examples of contactors and relays         | ISKRA IKA225-02      |



# Status codes and remedy

---

## Status Codes

---

### 1030 - WSD Open (operation LED: lights up red)

- Cause: A device connected in the WSD chain has interrupted the signal line (e.g. a surge protective device) or the bypass ex works has been removed and no trigger device has been installed.
- Display: On the inverter website in the "System" → "Event Log" menu or in the user menu under "Notifications" or in Fronius Solar.web.
- Remedy: If the SPD surge protective device is triggered, the inverter must be repaired by an authorised specialist.
- OR: Install the bypass ex works or a trigger device.
- OR: Set the WSD (wired shutdown) switch to position 1 (WSD primary device).



### **WARNING!**

#### **Danger due to work that has been carried out incorrectly.**

This can result in serious injury and damage to property.

- ▶ Installing and connecting a surge protective device (SPD) must only be carried out by service personnel trained by Fronius and only within the scope of the respective technical regulations.
  - ▶ Follow the safety rules.
- 
-

# Technical data

**Fronius Primo  
GEN24 3.0 / 3.0  
Plus**

| <b>DC input data</b>  |                             |
|---|-----------------------------|
| MPP voltage range<br>(at rated power)   | 190 - 530 V                 |
| Max. input voltage<br>at 1000 W/m <sup>2</sup> /-10°C in an open circuit                                  | 600 V                       |
| Min. input voltage  | 65 V                        |
| Feed in start-up input voltage in grid operation <sup>5)</sup>  | 80 V                        |
| Max. input current<br>PV 1<br>PV 2  | 22.0 A<br>12.0 A            |
| Max. short circuit current of solar modules<br>(I <sub>SC PV</sub> )<br>PV 1<br>PV 2                      | 33 A<br>18 A                |
| Max. short circuit current<br>(I <sub>SC PV1</sub> + I <sub>SC PV2</sub> = I <sub>SC max</sub> )<br>Total | 51 A                        |
| Max. inverter backfeed current to the array <sup>3)</sup>   | 33 / 18 A                   |
| Number of inputs - PV 1   | 2                           |
| Number of inputs - PV 2   | 2                           |
| Max. capacity of the PV generator against earth   | 600 nF                      |
| <b>DC input data battery</b>  |                             |
| Max. voltage  | 455 V                       |
| Min. voltage  | 150 V                       |
| Max. current  | 22 A                        |
| Max. output   | 3000 W                      |
| DC inputs   | 1                           |
| <b>AC input/output data</b>   |                             |
| Nominal output power (P <sub>nom</sub> )  | 3000 W                      |
| Max. output power   | 3000 W                      |
| Rated apparent power  | 3000 W                      |
| Nominal grid voltage  | 1 ~ NPE 220V / 230V / 240 V |
| Min. grid voltage   | 155 V <sup>1)</sup>         |
| Max. grid voltage   | 270 V <sup>1)</sup>         |
| Max. output current   | 19.4 A                      |
| Current (inrush) <sup>6)</sup>  | 20 A / 1.3 ms               |
| Nominal frequency   | 50 / 60 Hz <sup>1)</sup>    |

|  |                                   |
|--|-----------------------------------|
| Nominal frequency for Full Backup                              | 53 / 63 Hz <sup>1)</sup>          |
| Total harmonic distortion                                      | < 2 %                             |
| Power factor cos phi <sup>2)</sup>                             | 0.8 - 1 (adjustable)              |
| Max. permitted mains impedance $Z_{\max}$ on PCC <sup>4)</sup> | None                              |
| Max. output fault current / duration                           | 29 A / 3 ms                       |
| <b>AC output data PV Point</b>                                 |                                   |
| Max. output power  | 4133 W (for 5 s)                  |
| Rated power  | 3000 W                            |
| Nominal output current   | 13 A                              |
| Nominal grid voltage   | 1 ~ NPE 220 V / 230 V / 240 V     |
| Nominal frequency  | 53 / 63 Hz <sup>1)</sup>          |
| Switchover time  | < 90 s                            |
| Power factor cos phi <sup>2)</sup>                             | 0 - 1                             |
| <b>AC output data Full Backup</b>                              |                                   |
| Max. output power  | 4133 W (for 5 s)                  |
| Rated power  | 3000 W                            |
| Nominal output current   | 13 A                              |
| Nominal grid voltage   | 1 ~ NPE 220 V                     |
|  | 1 ~ NPE 230 V                     |
|  | 1 ~ NPE 240 V                     |
| Nominal frequency for Full Backup                              | 53 / 63 Hz <sup>1)</sup>          |
| Switchover time  | < 90 s                            |
| Power factor cos phi <sup>2)</sup>                             | 0 - 1                             |
| <b>General data</b>  |                                   |
| Maximum efficiency   | 97.6 %                            |
| European efficiency ( $U_{\text{mpp nom}}$ )                   | 96.8 %                            |
| European efficiency ( $U_{\text{mpp max}}$ )                   | 95.9 %                            |
| European efficiency ( $U_{\text{mpp min}}$ )                   | 95.3 %                            |
| Self-consumption at night                                      | 8.2 W                             |
| Cooling  | Controlled forced-air ventilation |
| Degree of protection   | IP 66                             |
| Dimensions H x W x D   | 530 × 474 × 165 mm                |
| Weight   | 17 kg                             |
| Permitted ambient temperature                                  | -40 °C – +60 °C                   |
| Permissible humidity   | 0 - 100% (incl. condensation)     |
| EMC emission class   | B                                 |
| DC/AC overvoltage category<br>(in accordance with IEC 62109-1) | 2/3                               |
| Pollution degree   | 2                                 |

|   |   |
|---|---|
| Sound pressure  | 42 dB(A) (ref. 20 $\mu$ Pa)   |
| Safety class (according to IEC62103)  | 1   |
| <b>Protection devices</b>   |   |
| DC isolation measurement  | Warning / shutdown at $R_{ISO} < 100 \text{ k}\Omega$               |
| Overload performance  | Operating point shift, power limiter                                |
| DC disconnect   | Integrated  |
| RCMU  | Integrated  |
| <b>Data communication</b>   |   |
| WLAN SMA-RP connection<br>( <b>FCC ID:</b> QKWPILOT01 / <b>IC ID:</b> 12270A-PILOT01) | 802.11b/g/n (WPA, WPA2)   |
| Ethernet (LAN)  | RJ45, 10/100 MBit   |
| USB (type A socket)   | max. 1 A at 5 V<br>(IO connection not connected)                    |
| Wired shutdown (WSD)  | max. 28 devices/WSD chain   |
|   | max. distance between two devices = 100 m                           |
| Modbus RTU SunSpec (2x)   | RS485 2-wire  |
| Voltage level of digital inputs   | low: min. 0 V - max. 1.8 V  |
|   | high: min. 4.5 V - max. 28.8 V                                      |
| Input currents of digital inputs  | depending on the input voltage;<br>input resistance = 70 k $\Omega$ |
| Total power for digital output<br>(internal supply)                                   | 6 W at 12 V (USB not connected)                                     |
| Power per digital output<br>(external supply)   | 1 A at >12.5 V-24 V<br>(max. 3 A in total)                          |
| Datalogger/web server   | Integrated  |

**Fronius Primo  
GEN24 3.6 / 3.6  
Plus**

| <b>DC input data</b>   |             |
|--|-------------|
| MPP voltage range<br>(at rated power)                                    | 200 - 530 V |
| Max. input voltage<br>at 1000 W/m <sup>2</sup> /-10°C in an open circuit | 600 V       |
| Min. input voltage   | 65 V        |
| Feed in start-up input voltage in grid operation <sup>5)</sup>           | 80 V        |
| Max. input current   | PV 1        |
|  | PV 2        |
| Max. short circuit current of solar modules<br>( $I_{SC \text{ PV}}$ )   | PV 1        |
|  | PV 2        |

|  |                               |
|--|-------------------------------|
| Max. short circuit current<br>( $I_{SC\ PV1} + I_{SC\ PV2} = I_{SC\ max}$ )<br>Total | 51 A                          |
| Max. inverter backfeed current to the array <sup>3)</sup>                            | 33 / 18 A                     |
| Number of inputs - PV 1  | 2                             |
| Number of inputs - PV 2  | 2                             |
| Max. capacity of the PV generator against earth                                      | 736 nF                        |
| <b>DC input data battery</b>   |                               |
| Max. voltage   | 455 V                         |
| Min. voltage   | 150 V                         |
| Max. current   | 22 A                          |
| Max. output  | 3680 W                        |
| DC inputs  | 1                             |
| <b>AC input/output data</b>  |                               |
| Nominal output power ( $P_{nom}$ )   | 3680 W                        |
| Max. output power  | 3680 W                        |
| Rated apparent power   | 3680 W                        |
| Nominal grid voltage   | 1 ~ NPE 220V / 230V / 240 V   |
| Min. grid voltage  | 155 V <sup>1)</sup>           |
| Max. grid voltage  | 270 V <sup>1)</sup>           |
| Max. output current  | 23.7 A                        |
| Current (inrush) <sup>6)</sup>   | 20 A / 1.3 ms                 |
| Nominal frequency  | 50 / 60 Hz <sup>1)</sup>      |
| Nominal frequency for Full Backup  | 53 / 63 Hz <sup>1)</sup>      |
| Total harmonic distortion  | < 2 %                         |
| Power factor $\cos\ \phi$ <sup>2)</sup>  | 0.8 - 1 (adjustable)          |
| Max. permitted mains impedance $Z_{max}$ on PCC <sup>4)</sup>                        | None                          |
| Max. output fault current / duration   | 29 A / 3 ms                   |
| <b>AC output data PV Point</b>   |                               |
| Max. output power  | 4133 W (for 5 s)              |
| Rated power  | 3000 W                        |
| Nominal output current   | 13 A                          |
| Nominal grid voltage   | 1 ~ NPE 220 V / 230 V / 240 V |
| Nominal frequency  | 53 / 63 Hz <sup>1)</sup>      |
| Switchover time  | < 90 s                        |
| Power factor $\cos\ \phi$ <sup>2)</sup>  | 0 - 1                         |
| <b>AC output data Full Backup</b>  |                               |

|   |  |
|---|--|
| Max. output power   | 5070 W (for 5 s)                                   |
| Rated power   | 3680 W   |
| Nominal output current  | 16 A   |
| Nominal grid voltage  | 1 ~ NPE 220 V                                      |
|   | 1 ~ NPE 230 V                                      |
|   | 1 ~ NPE 240 V                                      |
| Nominal frequency for Full Backup   | 53 / 63 Hz <sup>1)</sup>                           |
| Switchover time   | < 90 s   |
| Power factor cos phi <sup>2)</sup>  | 0 - 1  |
| <b>General data</b>   |  |
| Maximum efficiency  | 97.6 %   |
| European efficiency ( $U_{mpp \text{ nom}}$ )   | 97.0 %   |
| European efficiency ( $U_{mpp \text{ max}}$ )   | 96.3 %   |
| European efficiency ( $U_{mpp \text{ min}}$ )   | 95.6 %   |
| Self-consumption at night   | 8.2 W  |
| Cooling   | Controlled forced-air ventilation                  |
| Degree of protection  | IP 66  |
| Dimensions H x W x D  | 530 × 474 × 165 mm                                 |
| Weight  | 17 kg  |
| Permitted ambient temperature   | -40 °C – +60 °C                                    |
| Permissible humidity  | 0 - 100% (incl. condensation)                      |
| EMC emission class  | B  |
| DC/AC overvoltage category<br>(in accordance with IEC 62109-1)                        | 2/3  |
| Pollution degree  | 2  |
| Sound pressure  | 42 dB(A) (ref. 20µPa)                              |
| Safety class (according to IEC62103)  | 1  |
| <b>Protection devices</b>   |  |
| DC isolation measurement  | Warning / shutdown at $R_{ISO} < 100 \text{ kOHM}$ |
| Overload performance  | Operating point shift, power limiter               |
| DC disconnecter   | Integrated   |
| RCMU  | Integrated   |
| <b>Data communication</b>   |  |
| WLAN SMA-RP connection<br>( <b>FCC ID:</b> QKWPILOT01 / <b>IC ID:</b> 12270A-PILOT01) | 802.11b/g/n (WPA, WPA2)                            |
| Ethernet (LAN)  | RJ45, 10/100 MBit                                  |
| USB (type A socket)   | max. 1 A at 5 V<br>(IO connection not connected)   |

|  |   |
|--|---|
| Wired shutdown (WSD)                             | max. 28 devices/WSD chain                                     |
|  | max. distance between two devices = 100 m                     |
| Modbus RTU SunSpec (2x)                          | RS485 2-wire  |
| Voltage level of digital inputs                  | low: min. 0 V - max. 1.8 V                                    |
|  | high: min. 4.5 V - max. 28.8 V                                |
| Input currents of digital inputs                 | depending on the input voltage;<br>input resistance = 70 kOhm |
| Total power for digital output (internal supply) | 6 W at 12 V (USB not connected)                               |
| Power per digital output (external supply)       | 1 A at >12.5 V-24 V<br>(max. 3 A in total)                    |
| Datalogger/web server                            | Integrated  |

**Fronius Primo  
GEN24 4.0 / 4.0  
Plus**

| <b>DC input data</b>   |                  |
|--|------------------|
| MPP voltage range (at rated power)   | 210 - 530 V      |
| Max. input voltage at 1000 W/m <sup>2</sup> /-10°C in an open circuit                                  | 600 V            |
| Min. input voltage   | 65 V             |
| Feed in start-up input voltage in grid operation <sup>5)</sup>   | 80 V             |
| Max. input current<br>PV 1<br>PV 2   | 22.0 A<br>12.0 A |
| Max. short circuit current of solar modules (I <sub>SC PV</sub> )<br>PV 1<br>PV 2                      | 33 A<br>18 A     |
| Max. short circuit current (I <sub>SC PV1</sub> + I <sub>SC PV2</sub> = I <sub>SC max</sub> )<br>Total | 51 A             |
| Max. inverter backfeed current to the array <sup>3)</sup>  | 33 / 18 A        |
| Number of inputs - PV 1  | 2                |
| Number of inputs - PV 2  | 2                |
| Max. capacity of the PV generator against earth  | 800 nF           |
| <b>DC input data battery</b>   |                  |
| Max. voltage   | 455 V            |
| Min. voltage   | 150 V            |
| Max. current   | 22 A             |
| Max. output  | 4000 W           |

|   |   |
|---|---|
| DC inputs   | 1   |
| <b>AC input/output data</b>                                   |   |
| Nominal output power ( $P_{nom}$ )                            | 4000 W  |
| Max. output power   | 4000 W  |
| Rated apparent power  | 4000 W  |
| Nominal grid voltage  | 1 ~ NPE 220V / 230V / 240 V                     |
| Min. grid voltage   | 155 V <sup>1)</sup>                             |
| Max. grid voltage   | 270 V <sup>1)</sup>                             |
| Max. output current   | 25.8 A  |
| Current (inrush) <sup>6)</sup>                                | 20 A / 1.3 ms                                   |
| Nominal frequency   | 50 / 60 Hz <sup>1)</sup>                        |
| Nominal frequency for Full Backup                             | 53 / 63 Hz <sup>1)</sup>                        |
| Total harmonic distortion                                     | < 2 %   |
| Power factor cos phi <sup>2)</sup>                            | 0.8 - 1 (adjustable)                            |
| Max. permitted mains impedance $Z_{max}$ on PCC <sup>4)</sup> | None  |
| Max. output fault current / duration                          | 29 A / 3 ms                                     |
| <b>AC output data PV Point</b>                                |   |
| Max. output power   | 4133 W (for 5 s)                                |
| Rated power   | 3000 W  |
| Nominal output current  | 13 A  |
| Nominal grid voltage  | 1 ~ NPE 220 V / 230 V / 240 V                   |
| Nominal frequency   | 53 / 63 Hz <sup>1)</sup>                        |
| Switchover time   | < 90 s  |
| Power factor cos phi <sup>2)</sup>                            | 0 - 1   |
| <b>AC output data Full Backup</b>                             |   |
| Max. output power   | 5510 W (for 5 s)                                |
| Rated power   | 4000 W  |
| Nominal output current  | 17.4 A  |
| Nominal grid voltage  | 1 ~ NPE 220 V<br>1 ~ NPE 230 V<br>1 ~ NPE 240 V |
| Nominal frequency for Full Backup                             | 53 / 63 Hz <sup>1)</sup>                        |
| Switchover time   | < 90 s  |
| Power factor cos phi <sup>2)</sup>                            | 0 - 1   |
| <b>General data</b>   |   |
| Maximum efficiency  | 97.6 %  |
| European efficiency ( $U_{mpp nom}$ )                         | 97.1 %  |
| European efficiency ( $U_{mpp max}$ )                         | 96.5 %  |



|  |   |
|--|---|
| European efficiency ( $U_{mpp \min}$ )                                 | 95.8 %  |
| Self-consumption at night  | 8.2 W   |
| Cooling  | Controlled forced-air ventilation                             |
| Degree of protection   | IP 66   |
| Dimensions H x W x D   | 530 × 474 × 165 mm  |
| Weight   | 17 kg   |
| Permitted ambient temperature  | -40 °C – +60 °C   |
| Permissible humidity   | 0 - 100% (incl. condensation)                                 |
| EMC emission class   | B   |
| DC/AC overvoltage category<br>(in accordance with IEC 62109-1)         | 2/3   |
| Pollution degree   | 2   |
| Sound pressure   | 42 dB(A) (ref. 20µPa)   |
| Safety class (according to IEC62103)                                   | 1   |
| <b>Protection devices</b>  |   |
| DC isolation measurement   | Warning / shutdown at $R_{ISO} < 100 \text{ kOHM}$            |
| Overload performance   | Operating point shift, power limiter                          |
| DC disconnecter  | Integrated  |
| RCMU   | Integrated  |
| <b>Data communication</b>  |   |
| WLAN SMA-RP connection<br>(FCC ID: QKWPILOT01 / IC ID: 12270A-PILOT01) | 802.11b/g/n (WPA, WPA2)                                       |
| Ethernet (LAN)   | RJ45, 10/100 MBit   |
| USB (type A socket)  | max. 1 A at 5 V<br>(IO connection not connected)              |
| Wired shutdown (WSD)   | max. 28 devices/WSD chain                                     |
|  | max. distance between two devices = 100 m                     |
| Modbus RTU SunSpec (2x)  | RS485 2-wire  |
| Voltage level of digital inputs  | low: min. 0 V - max. 1.8 V                                    |
|  | high: min. 4.5 V - max. 28.8 V                                |
| Input currents of digital inputs                                       | depending on the input voltage;<br>input resistance = 70 kOhm |
| Total power for digital output<br>(internal supply)                    | 6 W at 12 V (USB not connected)                               |
| Power per digital output<br>(external supply)                          | 1 A at >12.5 V-24 V<br>(max. 3 A in total)                    |
| Datalogger/web server  | Integrated  |

**Fronius Primo  
GEN24 4.6 / 4.6  
Plus**

| <b>DC input data</b>  |                             |
|---|-----------------------------|
| MPP voltage range<br>(at rated power)   | 230 - 530 V                 |
| Max. input voltage<br>at 1000 W/m <sup>2</sup> /-10°C in an open circuit                                  | 600 V                       |
| Min. input voltage  | 65 V                        |
| Feed in start-up input voltage in grid operation <sup>5)</sup>  | 80 V                        |
| Max. input current<br>PV 1<br>PV 2  | 22.0 A<br>12.0 A            |
| Max. short circuit current of solar modules<br>(I <sub>SC PV</sub> )<br>PV 1<br>PV 2                      | 33 A<br>18 A                |
| Max. short circuit current<br>(I <sub>SC PV1</sub> + I <sub>SC PV2</sub> = I <sub>SC max</sub> )<br>Total | 51 A                        |
| Max. inverter backfeed current to the array <sup>3)</sup>   | 33 / 18 A                   |
| Number of inputs - PV 1   | 2                           |
| Number of inputs - PV 2   | 2                           |
| Max. capacity of the PV generator against earth   | 920 nF                      |
| <b>DC input data battery</b>  |                             |
| Max. voltage  | 455 V                       |
| Min. voltage  | 150 V                       |
| Max. current  | 22 A                        |
| Max. output   | 4600 W                      |
| DC inputs   | 1                           |
| <b>AC input/output data</b>   |                             |
| Nominal output power (P <sub>nom</sub> )  | 4600 W                      |
| Max. output power   | 4600 W                      |
| Rated apparent power  | 4600 W                      |
| Nominal grid voltage  | 1 ~ NPE 220V / 230V / 240 V |
| Min. grid voltage   | 155 V <sup>1)</sup>         |
| Max. grid voltage   | 270 V <sup>1)</sup>         |
| Max. output current   | 27.5 A                      |
| Current (inrush) <sup>6)</sup>  | 20 A / 1.3 ms               |
| Nominal frequency   | 50 / 60 Hz <sup>1)</sup>    |
| Nominal frequency for Full Backup   | 53 / 63 Hz <sup>1)</sup>    |
| Total harmonic distortion   | < 2 %                       |

|  |                                   |
|--|-----------------------------------|
| Power factor $\cos \phi$ <sup>2)</sup>                         | 0.8 - 1 (adjustable)              |
| Max. permitted mains impedance $Z_{\max}$ on PCC <sup>4)</sup> | None                              |
| Max. output fault current / duration                           | 29 A / 3 ms                       |
| <b>AC output data PV Point</b>                                 |                                   |
| Max. output power  | 4133 W (for 5 s)                  |
| Rated power  | 3000 W                            |
| Nominal output current   | 13 A                              |
| Nominal grid voltage   | 1 ~ NPE 220 V / 230 V / 240 V     |
| Nominal frequency  | 53 / 63 Hz <sup>1)</sup>          |
| Switchover time  | < 90 s                            |
| Power factor $\cos \phi$ <sup>2)</sup>                         | 0 - 1                             |
| <b>AC output data Full Backup</b>                              |                                   |
| Max. output power  | 6338 W (for 5 s)                  |
| Rated power  | 4600 W                            |
| Nominal output current   | 20 A                              |
| Nominal grid voltage   | 1 ~ NPE 220 V                     |
|  | 1 ~ NPE 230 V                     |
|  | 1 ~ NPE 240 V                     |
| Nominal frequency for Full Backup                              | 53 / 63 Hz <sup>1)</sup>          |
| Switchover time  | < 90 s                            |
| Power factor $\cos \phi$ <sup>2)</sup>                         | 0 - 1                             |
| <b>General data</b>  |                                   |
| Maximum efficiency   | 97.6 %                            |
| European efficiency ( $U_{\text{mpp nom}}$ )                   | 97.2 %                            |
| European efficiency ( $U_{\text{mpp max}}$ )                   | 96.6 %                            |
| European efficiency ( $U_{\text{mpp min}}$ )                   | 96.2 %                            |
| Self-consumption at night                                      | 8.2 W                             |
| Cooling  | Controlled forced-air ventilation |
| Degree of protection   | IP 66                             |
| Dimensions H x W x D   | 530 × 474 × 165 mm                |
| Weight   | 17 kg                             |
| Permitted ambient temperature                                  | -40 °C – +60 °C                   |
| Permissible humidity   | 0 - 100% (incl. condensation)     |
| EMC emission class   | B                                 |
| DC/AC overvoltage category<br>(in accordance with IEC 62109-1) | 2/3                               |
| Pollution degree   | 2                                 |
| Sound pressure   | 42 dB(A) (ref. 20µPa)             |

|  |   |
|--|---|
| Safety class (according to IEC62103)                                   | 1   |
| <b>Protection devices</b>  |   |
| DC isolation measurement   | Warning / shutdown at $R_{ISO} < 100 \text{ k}\Omega$               |
| Overload performance   | Operating point shift, power limiter                                |
| DC disconnect  | Integrated  |
| RCMU   | Integrated  |
| <b>Data communication</b>  |   |
| WLAN SMA-RP connection<br>(FCC ID: QKWPILOT01 / IC ID: 12270A-PILOT01) | 802.11b/g/n (WPA, WPA2)   |
| Ethernet (LAN)   | RJ45, 10/100 MBit   |
| USB (type A socket)  | max. 1 A at 5 V<br>(IO connection not connected)                    |
| Wired shutdown (WSD)   | max. 28 devices/WSD chain   |
|  | max. distance between two devices = 100 m                           |
| Modbus RTU SunSpec (2x)  | RS485 2-wire  |
| Voltage level of digital inputs  | low: min. 0 V - max. 1.8 V  |
|  | high: min. 4.5 V - max. 28.8 V                                      |
| Input currents of digital inputs                                       | depending on the input voltage;<br>input resistance = 70 k $\Omega$ |
| Total power for digital output<br>(internal supply)                    | 6 W at 12 V (USB not connected)                                     |
| Power per digital output<br>(external supply)                          | 1 A at >12.5 V-24 V<br>(max. 3 A in total)                          |
| Datalogger/web server  | Integrated  |

**Fronius Primo  
GEN24 5.0 / 5.0  
Plus**

| <b>DC input data</b>   |             |
|--|-------------|
| MPP voltage range<br>(at rated power)  | 230 - 530 V |
| Max. input voltage<br>at 1000 W/m <sup>2</sup> /-10°C in an open circuit             | 600 V       |
| Min. input voltage   | 65 V        |
| Feed in start-up input voltage in grid operation <sup>5)</sup>                       | 80 V        |
| Max. input current<br>PV 1<br>PV 2   | 22.0 A      |
|  | 12.0 A      |
| Max. short circuit current of solar modules<br>(I <sub>SC PV</sub> )<br>PV 1<br>PV 2 | 33 A        |
|  | 18 A        |
|  |             |

|  |                               |
|--|-------------------------------|
| Max. short circuit current<br>( $I_{SC\ PV1} + I_{SC\ PV2} = I_{SC\ max}$ )<br>Total | 51 A                          |
| Max. inverter backfeed current to the array <sup>3)</sup>                            | 33 / 18 A                     |
| Number of inputs - PV 1  | 2                             |
| Number of inputs - PV 2  | 2                             |
| Max. capacity of the PV generator against earth                                      | 1000 nF                       |
| <b>DC input data battery</b>   |                               |
| Max. voltage   | 455 V                         |
| Min. voltage   | 150 V                         |
| Max. current   | 22 A                          |
| Max. output  | 5000 W                        |
| DC inputs  | 1                             |
| <b>AC input/output data</b>  |                               |
| Nominal output power ( $P_{nom}$ )   | 5000 W                        |
| Max. output power  | 5000 W                        |
| Rated apparent power   | 5000 W                        |
| Nominal grid voltage   | 1 ~ NPE 220V / 230V / 240 V   |
| Min. grid voltage  | 155 V <sup>1)</sup>           |
| Max. grid voltage  | 270 V <sup>1)</sup>           |
| Max. output current  | 27.5 A                        |
| Current (inrush) <sup>6)</sup>   | 20 A / 1.3 ms                 |
| Nominal frequency  | 50 / 60 Hz <sup>1)</sup>      |
| Nominal frequency for Full Backup  | 53 / 63 Hz <sup>1)</sup>      |
| Total harmonic distortion  | < 2 %                         |
| Power factor $\cos\ \phi$ <sup>2)</sup>  | 0.8 - 1 (adjustable)          |
| Max. permitted mains impedance $Z_{max}$ on PCC <sup>4)</sup>                        | None                          |
| Max. output fault current / duration   | 29 A / 3 ms                   |
| <b>AC output data PV Point</b>   |                               |
| Max. output power  | 4133 W (for 5 s)              |
| Rated power  | 3000 W                        |
| Nominal output current   | 13 A                          |
| Nominal grid voltage   | 1 ~ NPE 220 V / 230 V / 240 V |
| Nominal frequency  | 53 / 63 Hz <sup>1)</sup>      |
| Switchover time  | < 90 s                        |
| Power factor $\cos\ \phi$ <sup>2)</sup>  | 0 - 1                         |
| <b>AC output data Full Backup</b>  |                               |

|   |  |
|---|--|
| Max. output power   | 6890 W (for 5 s)                                 |
| Rated power   | 5000 W   |
| Nominal output current  | 21.7 A   |
| Nominal grid voltage  | 1 ~ NPE 220 V                                    |
|   | 1 ~ NPE 230 V                                    |
|   | 1 ~ NPE 240 V                                    |
| Nominal frequency for Full Backup   | 53 / 63 Hz <sup>1)</sup>                         |
| Switchover time   | < 90 s   |
| Power factor cos phi <sup>2)</sup>  | 0 - 1  |
| <b>General data</b>   |  |
| Maximum efficiency  | 97.6 %   |
| European efficiency ( $U_{mpp\ nom}$ )  | 97.2 %   |
| European efficiency ( $U_{mpp\ max}$ )  | 96.7 %   |
| European efficiency ( $U_{mpp\ min}$ )  | 96.3 %   |
| Self-consumption at night   | 8.2 W  |
| Cooling   | Controlled forced-air ventilation                |
| Degree of protection  | IP 66  |
| Dimensions H x W x D  | 530 × 474 × 165 mm                               |
| Weight  | 17 kg  |
| Permitted ambient temperature   | -40 °C – +60 °C                                  |
| Permissible humidity  | 0 - 100% (incl. condensation)                    |
| EMC emission class  | B  |
| DC/AC overvoltage category<br>(in accordance with IEC 62109-1)                        | 2/3  |
| Pollution degree  | 2  |
| Sound pressure  | 42 dB(A) (ref. 20µPa)                            |
| Safety class (according to IEC62103)  | 1  |
| <b>Protection devices</b>   |  |
| DC isolation measurement  | Warning / shutdown at $R_{ISO} < 100\ k\Omega$   |
| Overload performance  | Operating point shift, power limiter             |
| DC disconnect   | Integrated                                       |
| RCMU  | Integrated                                       |
| <b>Data communication</b>   |  |
| WLAN SMA-RP connection<br>( <b>FCC ID:</b> QKWPILOT01 / <b>IC ID:</b> 12270A-PILOT01) | 802.11b/g/n (WPA, WPA2)                          |
| Ethernet (LAN)  | RJ45, 10/100 MBit                                |
| USB (type A socket)   | max. 1 A at 5 V<br>(IO connection not connected) |

|  |   |
|--|---|
| Wired shutdown (WSD)                             | max. 28 devices/WSD chain                                     |
|  | max. distance between two devices = 100 m                     |
| Modbus RTU SunSpec (2x)                          | RS485 2-wire  |
| Voltage level of digital inputs                  | low: min. 0 V - max. 1.8 V                                    |
|  | high: min. 4.5 V - max. 28.8 V                                |
| Input currents of digital inputs                 | depending on the input voltage;<br>input resistance = 70 kOhm |
| Total power for digital output (internal supply) | 6 W at 12 V (USB not connected)                               |
| Power per digital output (external supply)       | 1 A at >12.5 V-24 V<br>(max. 3 A in total)                    |
| Datalogger/web server                            | Integrated  |

**Fronius Primo  
GEN24 6.0 / 6.0  
Plus**

| <b>DC input data</b>   |                  |
|--|------------------|
| MPP voltage range (at rated power)   | 230 - 480 V      |
| Max. input voltage at 1000 W/m <sup>2</sup> /-10°C in an open circuit                                  | 600 V            |
| Min. input voltage   | 65 V             |
| Feed in start-up input voltage in grid operation <sup>5)</sup>   | 80 V             |
| Max. input current<br>PV 1<br>PV 2   | 22.0 A<br>12.0 A |
| Max. short circuit current of solar modules (I <sub>SC PV</sub> )<br>PV 1<br>PV 2                      | 33 A<br>18 A     |
| Max. short circuit current (I <sub>SC PV1</sub> + I <sub>SC PV2</sub> = I <sub>SC max</sub> )<br>Total | 51 A             |
| Max. inverter backfeed current to the array <sup>3)</sup>  | 33 / 18 A        |
| Number of inputs - PV 1  | 2                |
| Number of inputs - PV 2  | 2                |
| Max. capacity of the PV generator against earth  | 1200 nF          |
| <b>DC input data battery</b>   |                  |
| Max. voltage   | 455 V            |
| Min. voltage   | 150 V            |
| Max. current   | 22 A             |
| Max. output  | 6000 W           |

|   |   |
|---|---|
| DC inputs   | 1   |
| <b>AC input/output data</b>                                   |   |
| Nominal output power ( $P_{nom}$ )                            | 6000 W  |
| Max. output power   | 6000 W  |
| Rated apparent power  | 6000 W  |
| Nominal grid voltage  | 1 ~ NPE 220V / 230V / 240 V                     |
| Min. grid voltage   | 155 V <sup>1)</sup>                             |
| Max. grid voltage   | 270 V <sup>1)</sup>                             |
| Max. output current   | 27.5 A  |
| Current (inrush) <sup>6)</sup>                                | 20 A / 1.3 ms                                   |
| Nominal frequency   | 50 / 60 Hz <sup>1)</sup>                        |
| Nominal frequency for Full Backup                             | 53 / 63 Hz <sup>1)</sup>                        |
| Total harmonic distortion                                     | < 2 %   |
| Power factor cos phi <sup>2)</sup>                            | 0.8 - 1 (adjustable)                            |
| Max. permitted mains impedance $Z_{max}$ on PCC <sup>4)</sup> | None  |
| Max. output fault current / duration                          | 29 A / 3 ms                                     |
| <b>AC output data PV Point</b>                                |   |
| Max. output power   | 4133 W (for 5 s)                                |
| Rated power   | 3000 W  |
| Nominal output current  | 13 A  |
| Nominal grid voltage  | 1 ~ NPE 220 V / 230 V / 240 V                   |
| Nominal frequency   | 53 / 63 Hz <sup>1)</sup>                        |
| Switchover time   | < 90 s  |
| Power factor cos phi <sup>2)</sup>                            | 0 - 1   |
| <b>AC output data Full Backup</b>                             |   |
| Max. output power   | 8268 W (for 5 s)                                |
| Rated power   | 6000 W  |
| Nominal output current  | 26.1 A  |
| Nominal grid voltage  | 1 ~ NPE 220 V<br>1 ~ NPE 230 V<br>1 ~ NPE 240 V |
| Nominal frequency for Full Backup                             | 53 / 63 Hz <sup>1)</sup>                        |
| Switchover time   | < 90 s  |
| Power factor cos phi <sup>2)</sup>                            | 0 - 1   |
| <b>General data</b>   |   |
| Maximum efficiency  | 97.6 %  |
| European efficiency ( $U_{mpp nom}$ )                         | 97.1 %  |
| European efficiency ( $U_{mpp max}$ )                         | 96.7 %  |



|  |   |
|--|---|
| European efficiency ( $U_{mpp \min}$ )                                 | 96.1 %  |
| Self-consumption at night  | 8.2 W   |
| Cooling  | Controlled forced-air ventilation                             |
| Degree of protection   | IP 66   |
| Dimensions H x W x D   | 530 × 474 × 165 mm  |
| Weight   | 17 kg   |
| Permitted ambient temperature  | -40 °C – +60 °C   |
| Permissible humidity   | 0 - 100% (incl. condensation)                                 |
| EMC emission class   | B   |
| DC/AC overvoltage category<br>(in accordance with IEC 62109-1)         | 2/3   |
| Pollution degree   | 2   |
| Sound pressure   | 42 dB(A) (ref. 20µPa)   |
| Safety class (according to IEC62103)                                   | 1   |
| <b>Protection devices</b>  |   |
| DC isolation measurement   | Warning / shutdown at $R_{ISO} < 100 \text{ kOHM}$            |
| Overload performance   | Operating point shift, power limiter                          |
| DC disconnecter  | Integrated  |
| RCMU   | Integrated  |
| <b>Data communication</b>  |   |
| WLAN SMA-RP connection<br>(FCC ID: QKWPILOT01 / IC ID: 12270A-PILOT01) | 802.11b/g/n (WPA, WPA2)                                       |
| Ethernet (LAN)   | RJ45, 10/100 MBit   |
| USB (type A socket)  | max. 1 A at 5 V<br>(IO connection not connected)              |
| Wired shutdown (WSD)   | max. 28 devices/WSD chain                                     |
|  | max. distance between two devices = 100 m                     |
| Modbus RTU SunSpec (2x)  | RS485 2-wire  |
| Voltage level of digital inputs  | low: min. 0 V - max. 1.8 V                                    |
|  | high: min. 4.5 V - max. 28.8 V                                |
| Input currents of digital inputs                                       | depending on the input voltage;<br>input resistance = 70 kOhm |
| Total power for digital output<br>(internal supply)                    | 6 W at 12 V (USB not connected)                               |
| Power per digital output<br>(external supply)                          | 1 A at >12.5 V-24 V<br>(max. 3 A in total)                    |
| Datalogger/web server  | Integrated  |

**Technical data of surge protective device DC SPD type 1+2 GEN24**

| <b>General data</b>   |   |
|---|---|
| Continuous operating current ( $I_{cpv}$ )  | < 0.1 mA  |
| Rated discharge current ( $I_n$ )<br>- 15 x 8/20 $\mu$ s pulses                   | 20 kA   |
| Lightning surge current ( $I_{imp}$ )<br>Max. discharge capacity @ 10/350 $\mu$ s | 6.25 kA   |
| Protection level ( $U_p$ )<br>(star-shaped mounting)                              | 4 kV  |
| Short-circuit strength PV ( $I_{scpv}$ )  | 15 kA   |
| <b>Disconnecter</b>   |   |
| Thermal disconnecter  | Integrated  |
| External fuse   | None  |
| <b>Mechanical properties</b>  |   |
| Disconnection indicator   | Mechanical indicator (red)  |
| Remote communication of the connection interruption                               | Output on the changeover contact                                      |
| Housing material  | Thermoplastic UL-94-V0  |
| Test standards  | IEC 61643-31 / DIN EN 50539-11<br>UL1449 ed.4 / VDE 0185-305-3 Bbl. 5 |

**Explanation of footnotes**

- 1) The values stated are defaults; the inverter is configured specifically to suit the requirements of the relevant country.
- 2) Depending on the country setup or device-specific settings (ind. = inductive; cap. = capacitive).
- 3) Maximum current from a defective PV module to all other PV modules. From the inverter itself to the PV side of the inverter, it is 0 A.
- 4) Guaranteed by the electrical configuration of the inverter.
- 5) For backup power mode (PV Point) without battery, a minimum voltage of 150 V is required.
- 6) Current peak when switching on the inverter.
- 7) The sum of the rated power per phase must not exceed the rated power of the inverter.
- 8) Valid for Fronius Primo GEN24 with battery connection and Fronius Primo GEN24 Plus.

**Integrated DC disconnecter**

| <b>General data</b>             |                      |
|---------------------------------|----------------------|
| Product name                    | Benedict LS32 E 7905 |
| Rated insulation voltage        | 1000 V <sub>DC</sub> |
| Rated impulse withstand voltage | 8 kV                 |

| Suitability for isolation                                    | Yes, DC only   |                            |                                     |                            |
|--|--|----------------------------|-------------------------------------|----------------------------|
| Utilization category and/or PV utilization category          | according to IEC/EN 60947-3 Category of utilization DC-PV2 |                            |                                     |                            |
| Rated short-time withstand current ( $I_{cw}$ )              | Rated short-time withstand current ( $I_{cw}$ ): 1000 A    |                            |                                     |                            |
| Rated short-circuit making capacity ( $I_{cm}$ )             | Rated short-circuit making capacity ( $I_{cm}$ ): 1000 A   |                            |                                     |                            |
| <b>Rated operational current and rated breaking capacity</b> |  |                            |                                     |                            |
| Rated operational voltage ( $U_e$ )                          | Rated operational current ( $I_e$ )                        | $I_{(make)} / I_{(break)}$ | rated operational current ( $I_e$ ) | $I_{(make)} / I_{(break)}$ |
| $\leq 500 V_{DC}$  | 14 A   | 56 A                       | 36 A                                | 144 A                      |
| 600 $V_{DC}$   | 8 A  | 32 A                       | 30 A                                | 120 A                      |
| 700 $V_{DC}$   | 3 A  | 12 A                       | 26 A                                | 88 A                       |
| 800 $V_{DC}$   | 3 A  | 12 A                       | 17 A                                | 68 A                       |
| 900 $V_{DC}$   | 2 A  | 8 A                        | 12 A                                | 48 A                       |
| 1000 $V_{DC}$  | 2 A  | 8 A                        | 6 A                                 | 24 A                       |
| Number of poles  | 1  | 1                          | 2                                   | 2                          |

# Circuit diagrams

# Circuit Diagram - PV Point (OP)

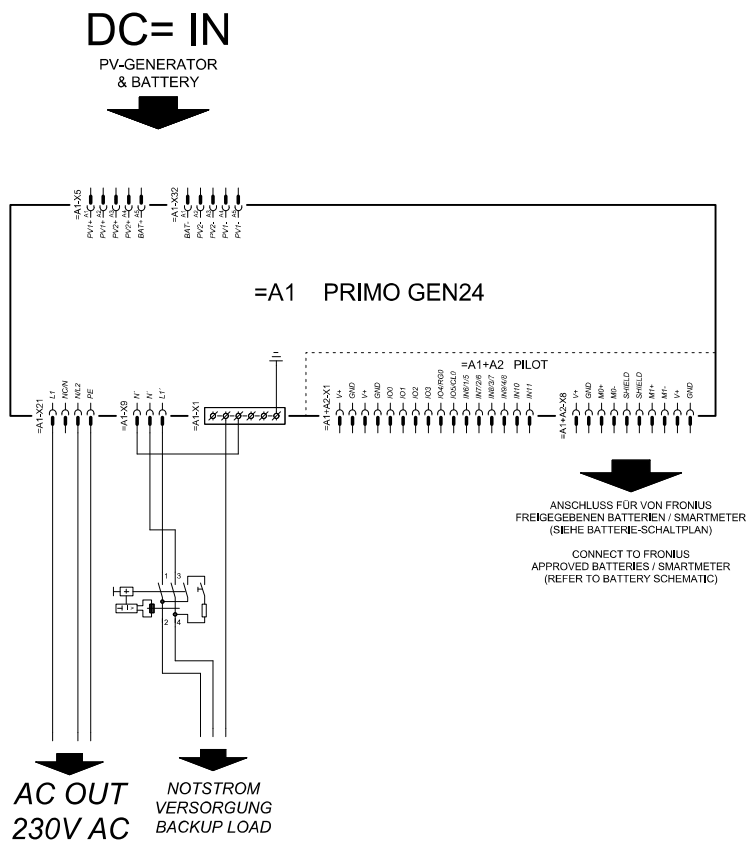

# Fronius Primo GEN24 and BYD Battery-Box Premium HV

Cir

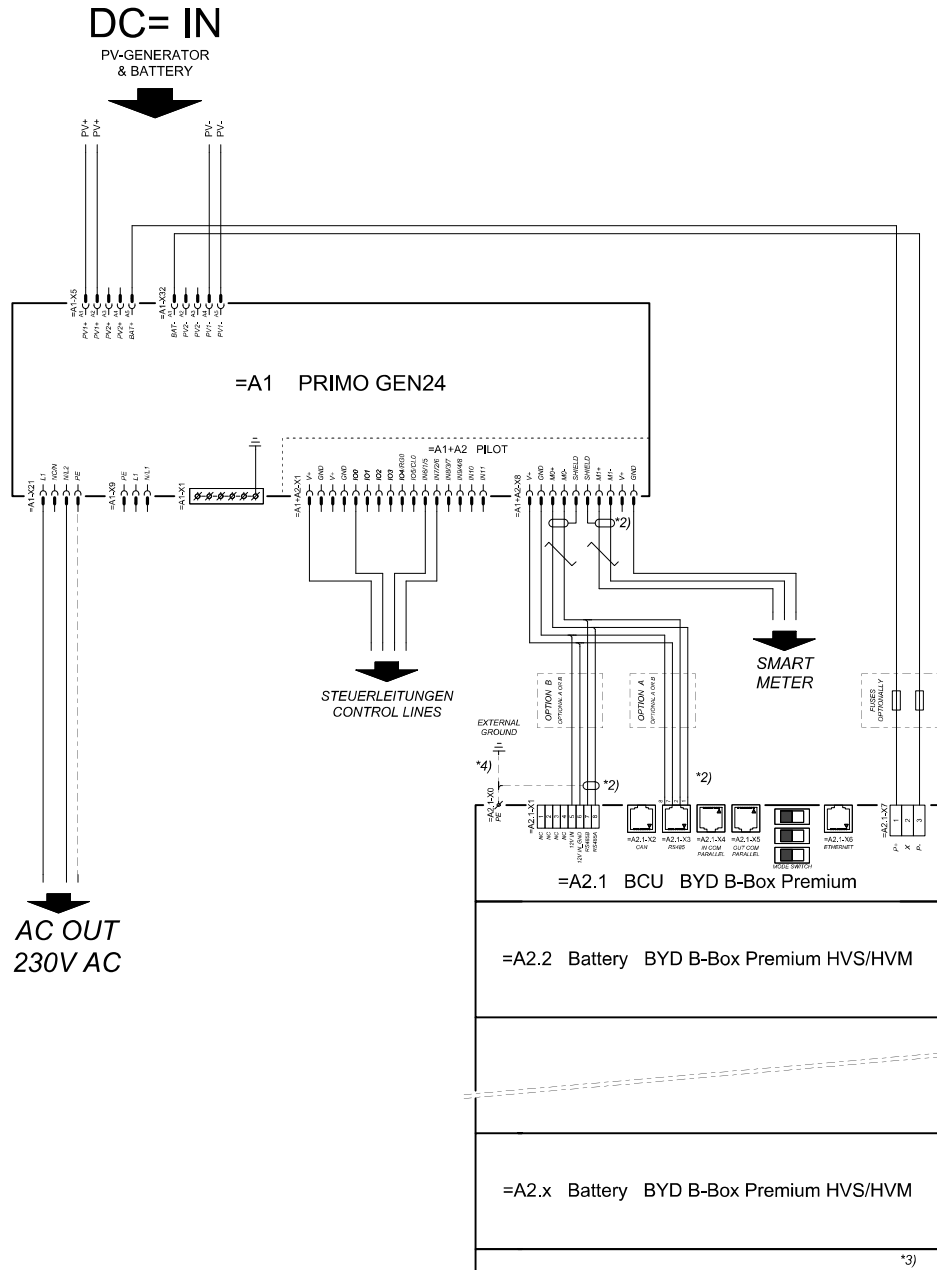

connection area at BCU:

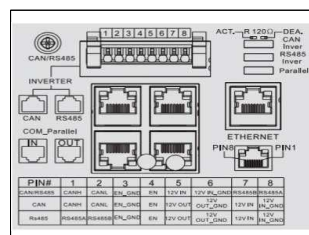

SYMBOL DEFINITION:

VERDRILLTE LEITUNG  
 TWISTED PAIR

\*2) DER MODBUS-KOMMUNIKATIONS-BUS ERFORDERT DEN ABSCHLUSS DER LEITUNGSLEITUNG MITTELS ABSCHLUSSWIDERSTÄNDE. DETAILS SIEHE WECHSELRICHTER-DOKUMENTATION.  
THE MODBUS COMMUNICATION BUS REQUIRES THE TERMINATION OF CABLES ENDS WITH TERMINATION RESISTORS. DETAILS ACCORDING INVERTER MANUAL.

\*3) MINIMALE ZULÄSSIGE MODULANZAHL:  
/AUT WECHSELRICHTER-DOKUMENTATION  
MINIMUM POSSIBLE NUMBER OF MODULES  
ACCORDING INVERTER MANUAL.

\*4) DEN QUERSCHNITT DER ERDUNGSLICHTUNG AUS DER DOKUMENTATION DER BYD BATTERY-BOX PREMIUM ENTNEHMEN (<= 10MM²)  
REFER PE CABLE CROSS-SECTION ACCORDING TO BYD BATTERY-BOX PREMIUM MANUAL (<= 10MM²)

# Fronius Primo GEN24 with two BYD Battery-Box Premium HV connected in parallel

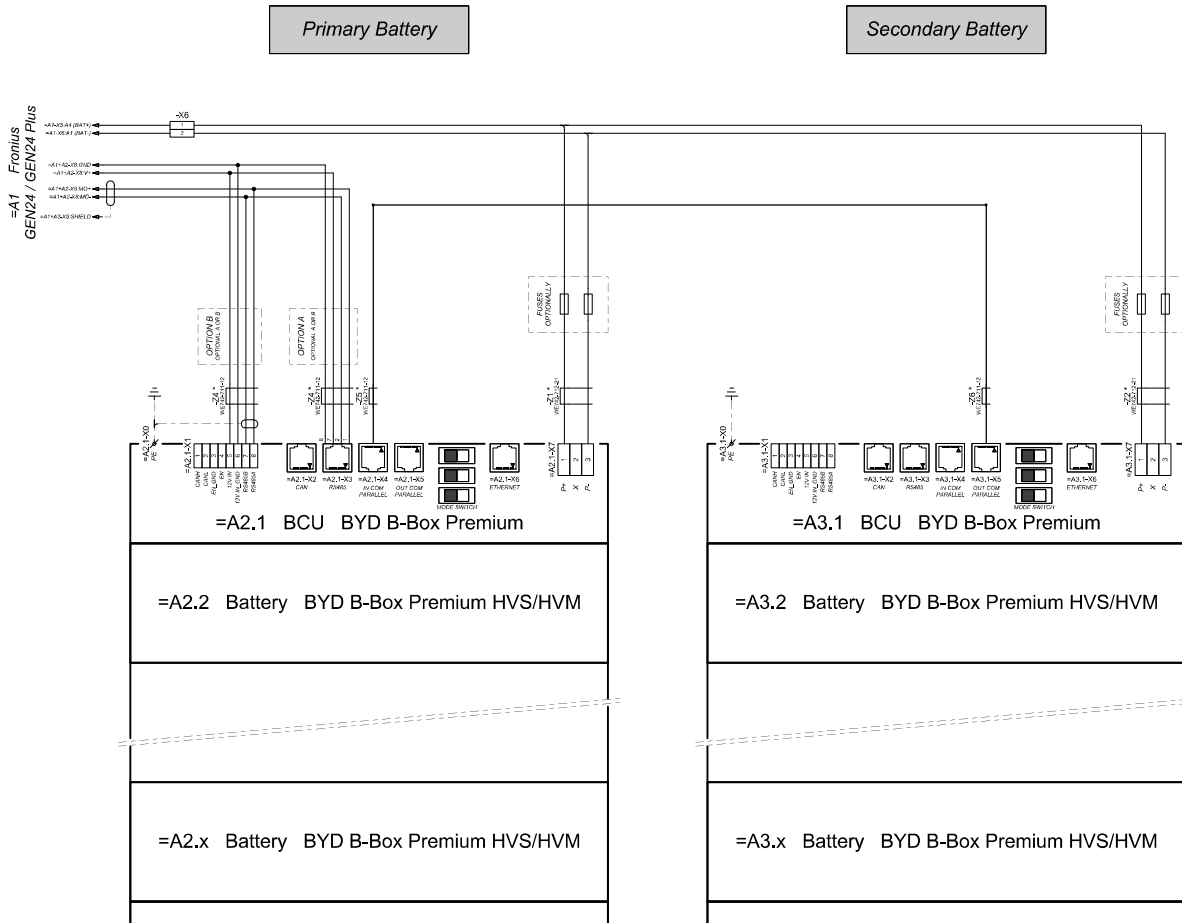

connection area at BCU's:

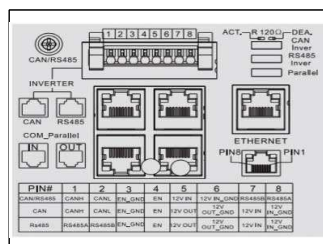

The ferrite cores -Z1 to -Z8 are only mandatory for storage installations in Italy!  
 Certified ferrites for DC connection path: -Z1 and -Z2: WE742-712-21, manufacturer: Würth  
 Certified ferrites for communication connection: -Z4 to -Z8: WE742-711-12, manufacturer: Würth

# Fronius Primo GEN24 with three BYD Battery-Box Premium HV connected in parallel

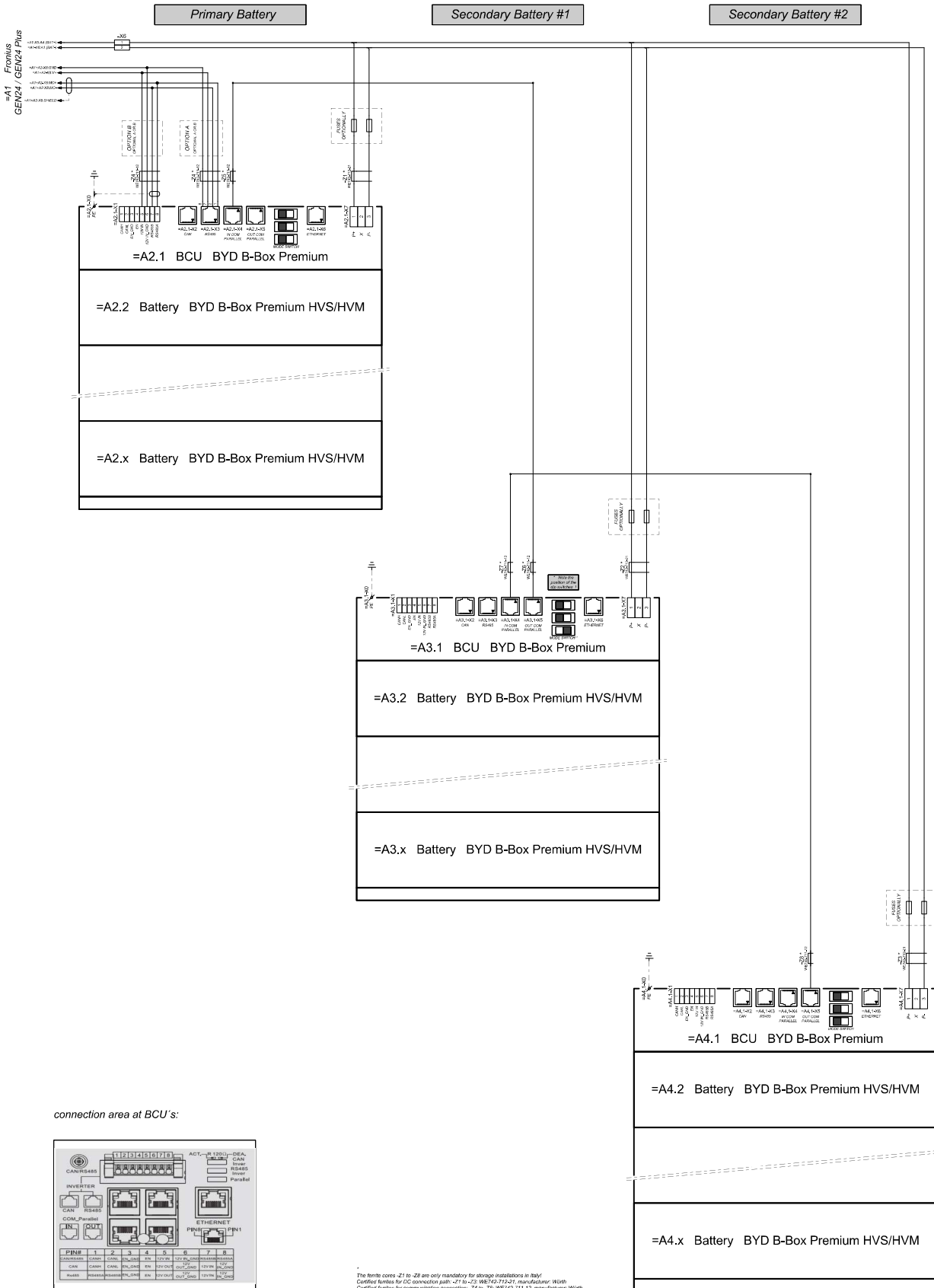

\* The ferrite cores -Z1 to -Z8 are only mandatory for storage installations in Italy.  
 Certified ferrites for DC connection path -Z1 to -Z2: W8742-715-21, manufacturer: Würth.  
 Certified ferrites for communication connection -Z4 to -Z8: WE542-711-10, manufacturer: Würth.



# Automatic switch to backup power 1-pin double separation - e.g. Austria

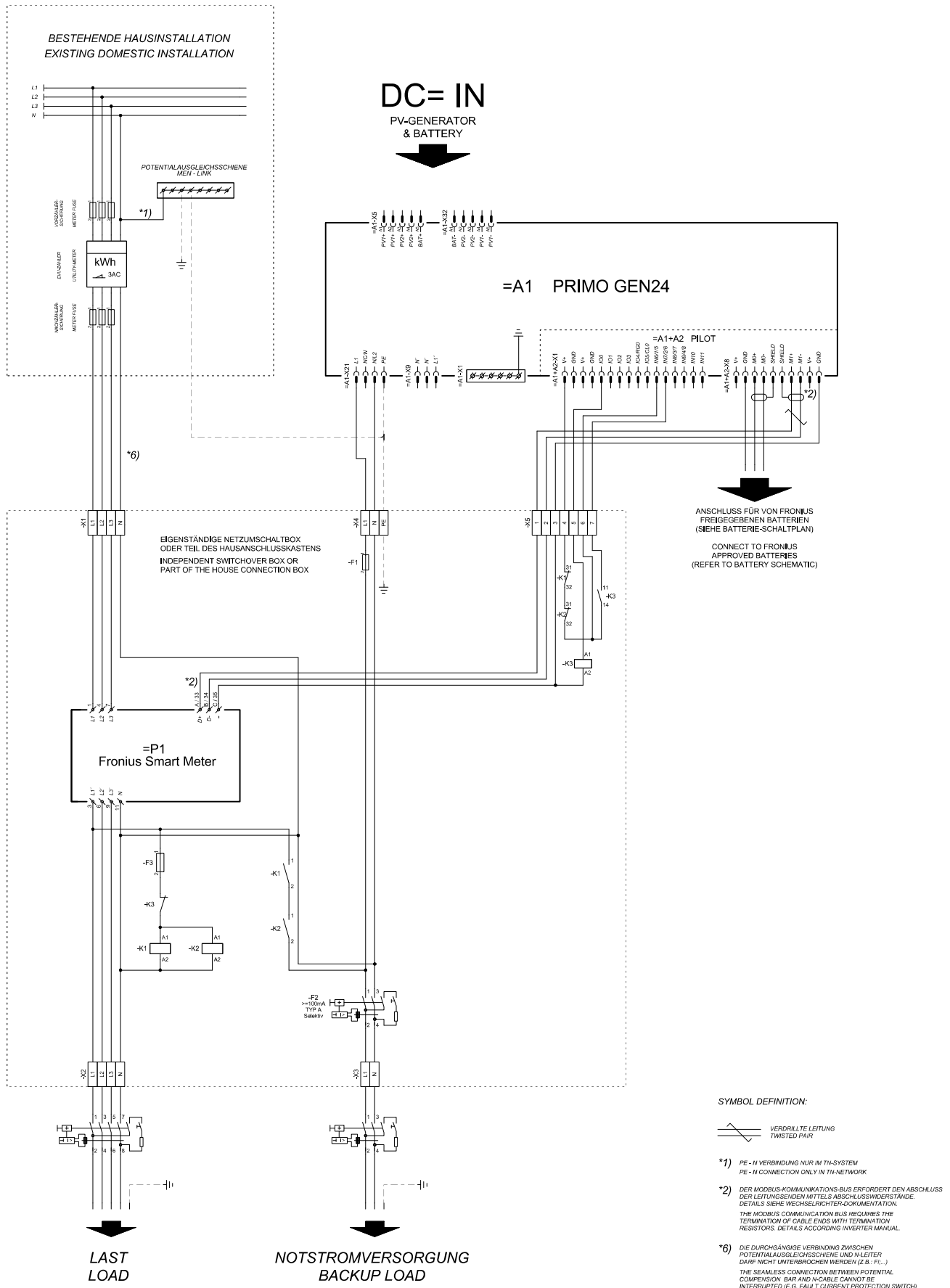

# Automatic switch to backup power 1-pin single separation - e.g. Australia

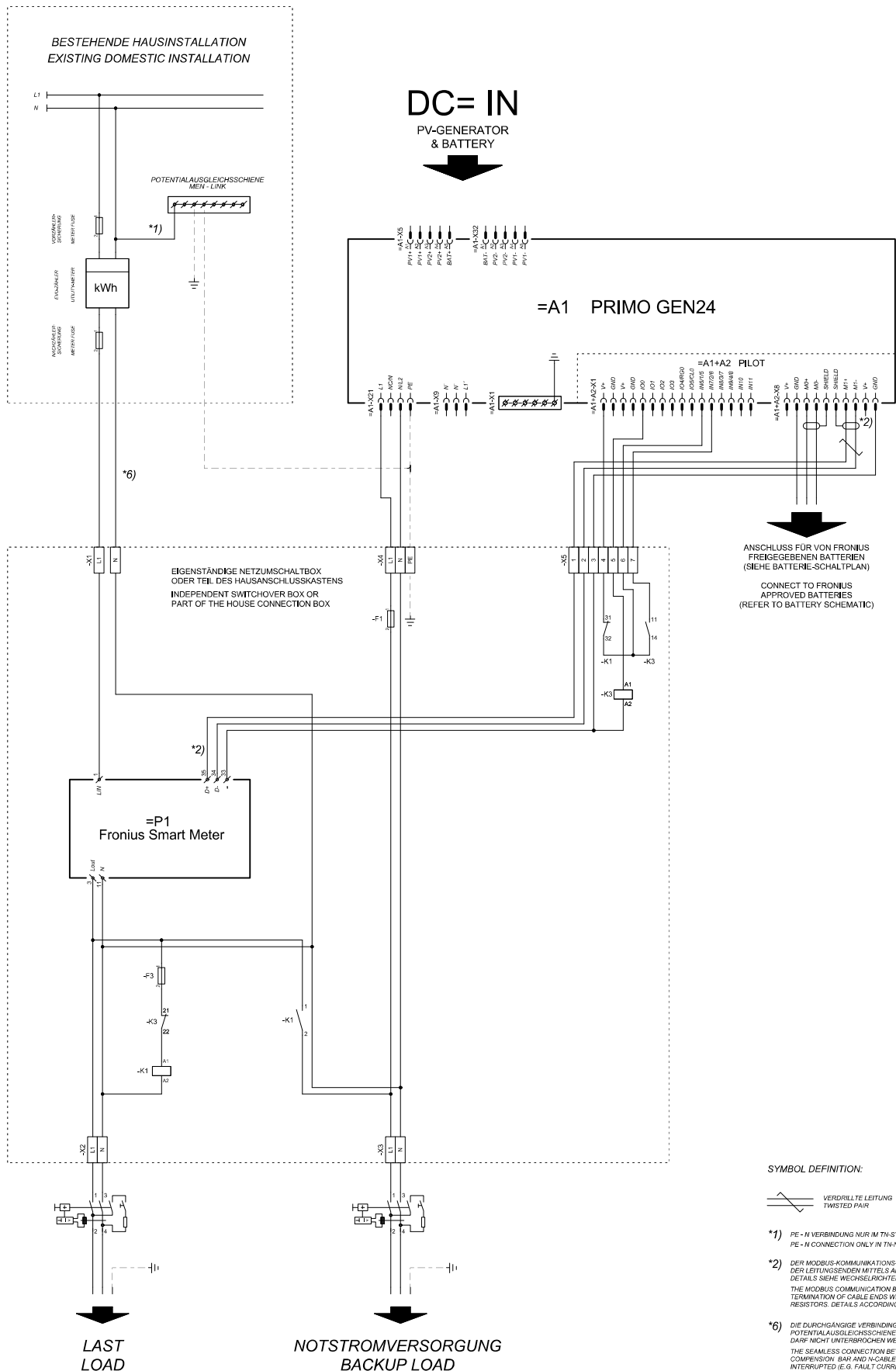

# Automatic switch to backup power 2-pin double separation - e.g. Germany

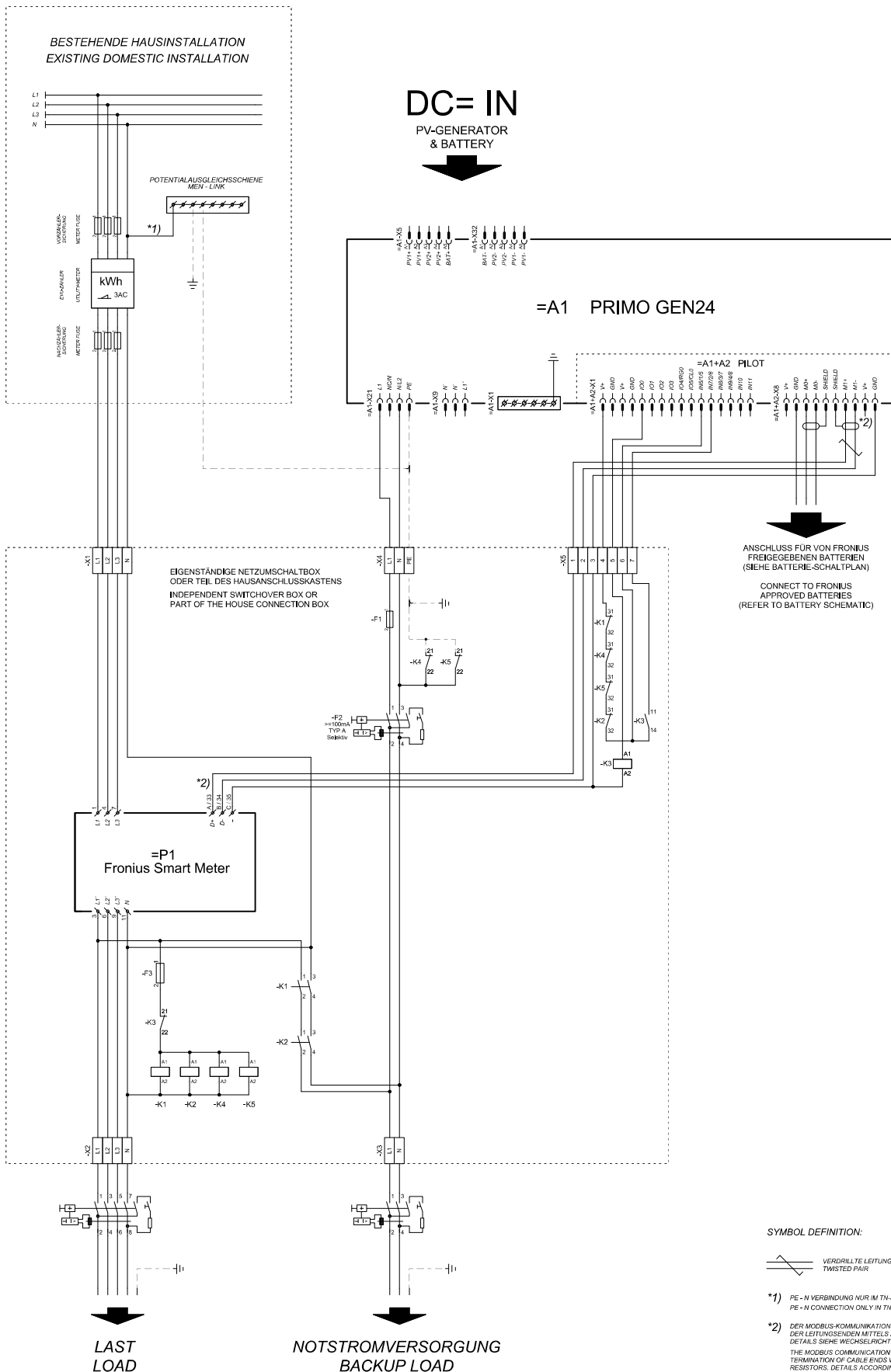

# Automatic switch to backup power 2-pin single separation - e.g. France, Spain

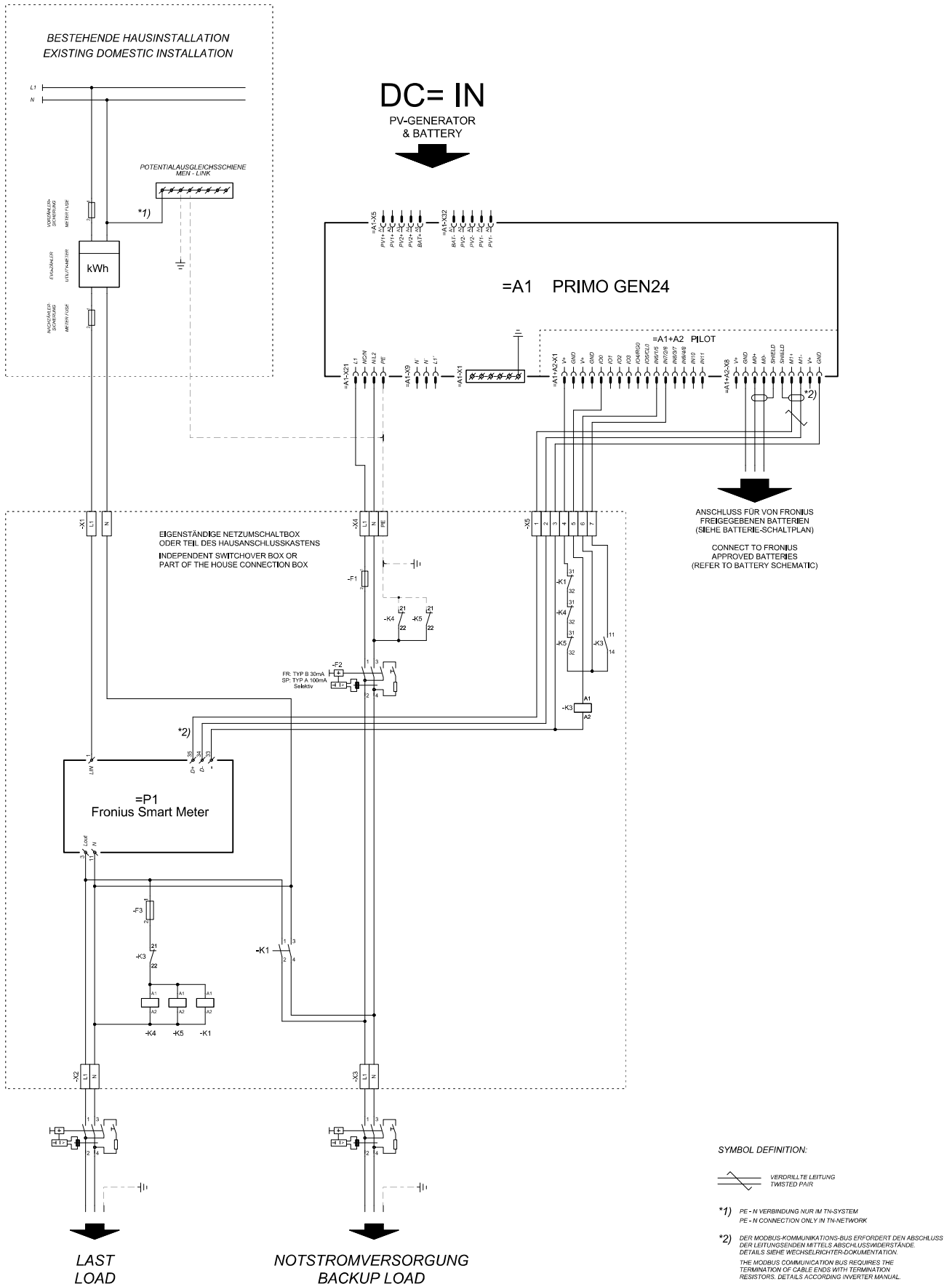

# Automatic switch to backup power 2-pin double separation - e.g. UK

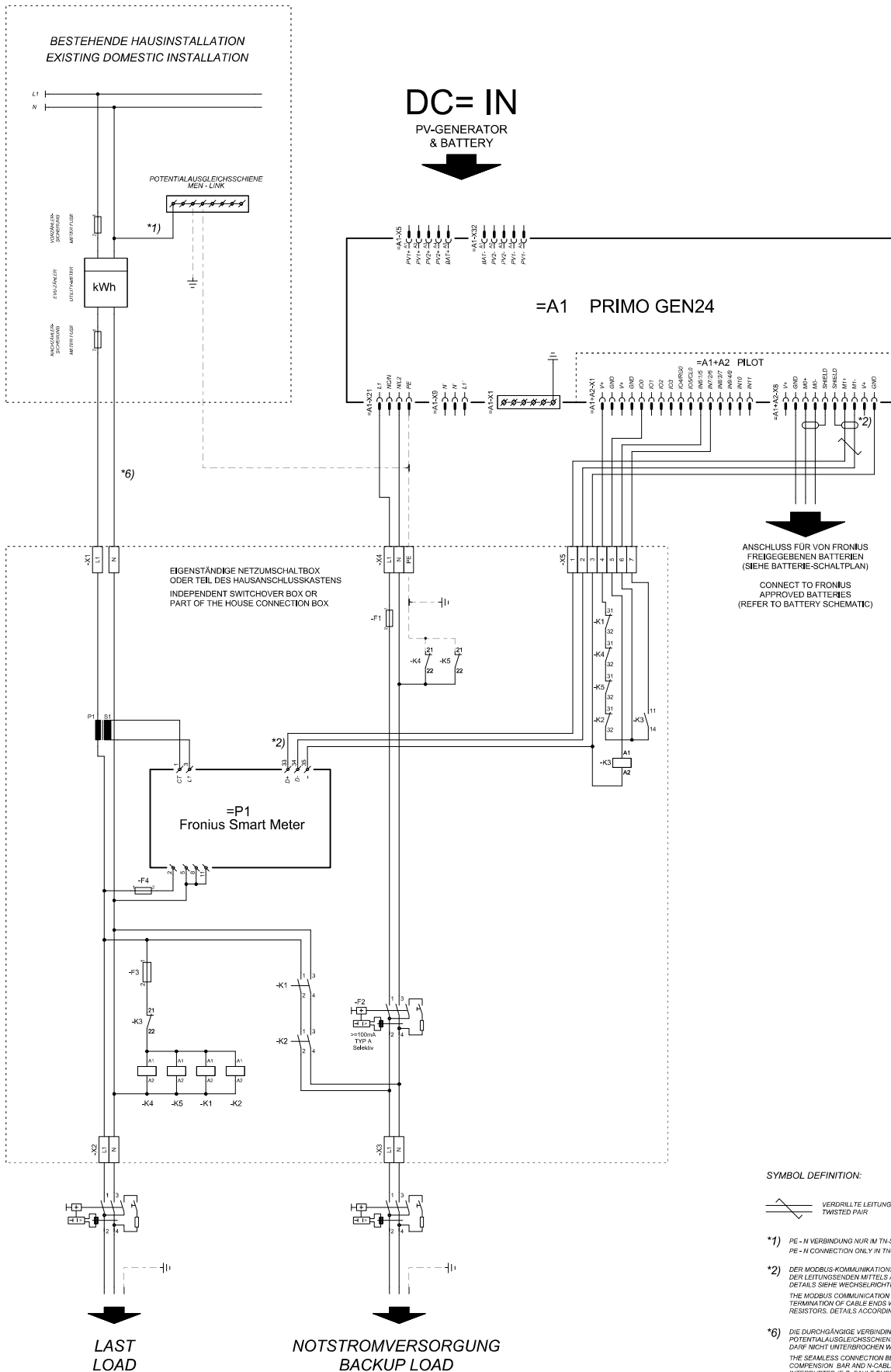

# Automatic switch to backup power 2-pin double separation with ext. grid and system protection - e.g. Italy

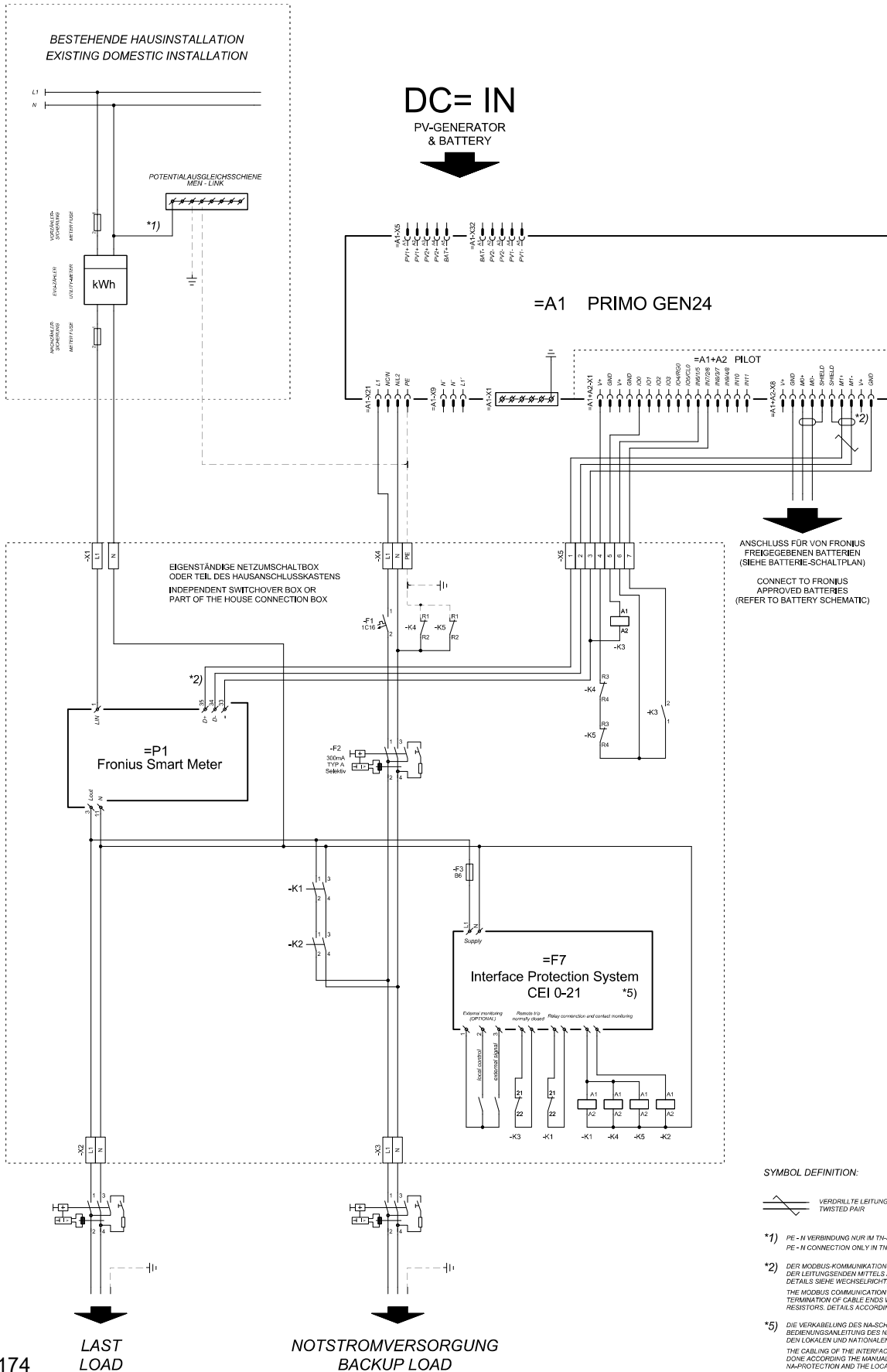

**SYMBOL DEFINITION:**



\*1) PE-N VERBINDUNG NUR IN TN-SYSTEM  
PE-N CONNECTION ONLY IN TN-SYSTEM

\*2) DER MODBUS-KOMMUNIKATIONS-BUS ERFORDERT DEN ABSCHLUSS DER LEITUNGSENDEN MITTELST ABSCHLUSSWIDERSTÄNDE.  
DETAILS SIEHE WECHSELRICHTER-DOKUMENTATION.  
THE MODBUS COMMUNICATION BUS REQUIRES THE TERMINATION OF CABLE ENDS WITH TERMINATION RESISTORS. DETAILS ACCORDING INVERTER MANUAL.

\*5) DIE VERKABELUNG DES NACHSCHUTZES MUSS GEMÄß DER BEDIENUNGSANLEITUNG DES NACHSCHUTZ-HERSTELLERS SOWIE DEN LOKALEN UND NATIONALEN BESTIMMUNGEN ERFOLGEN.  
THE CABLING OF THE INTERFACE PROTECTION SYSTEM HAS TO BE DONE ACCORDING TO THE MANUAL OF THE MANUFACTURER OF THE NA-PROTECTION AND THE LOCAL AND NATIONAL REQUIREMENTS

# Fronius Primo GEN24 with Enwitec Box

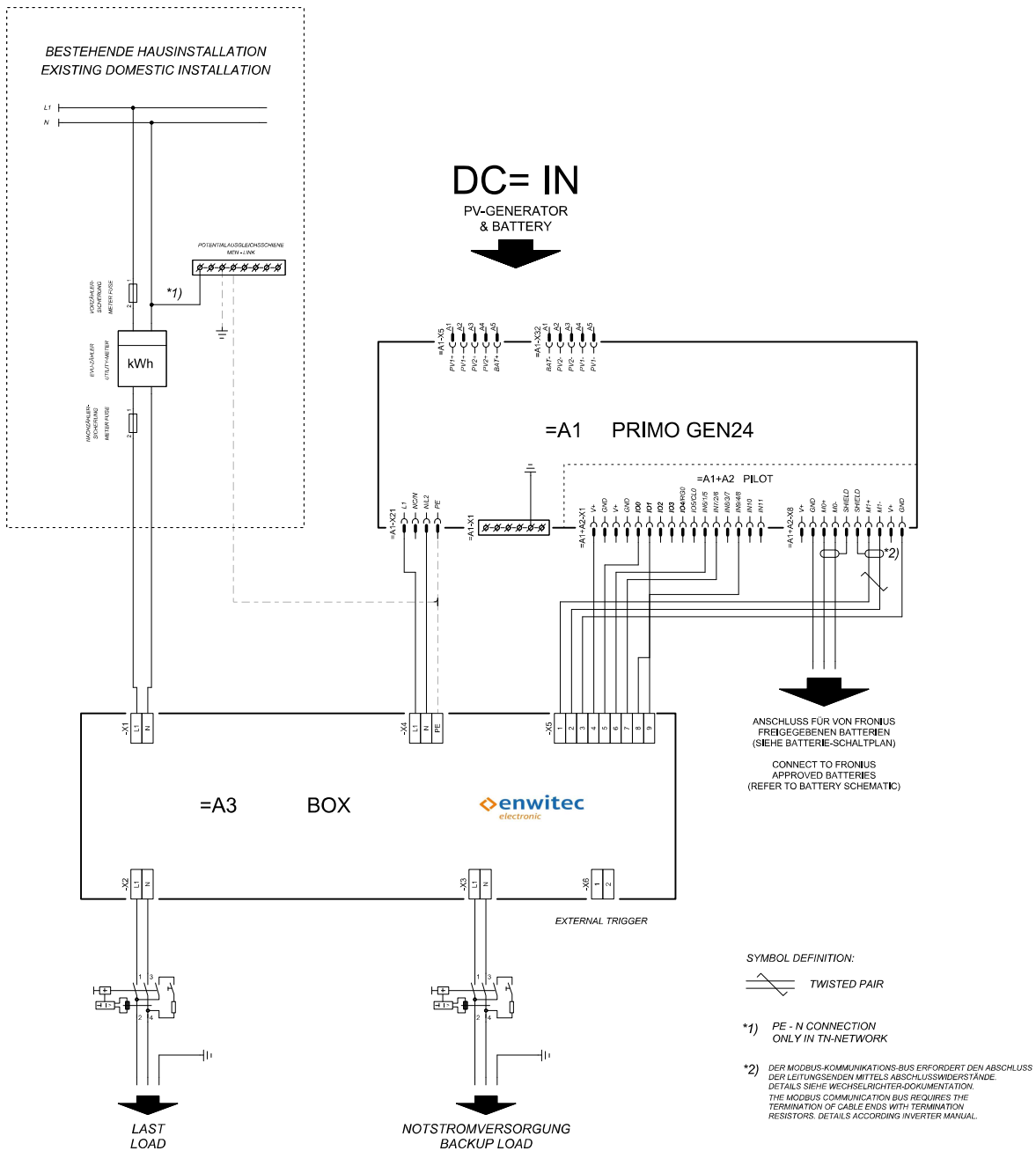

# Wiring diagram - surge protective device SPD

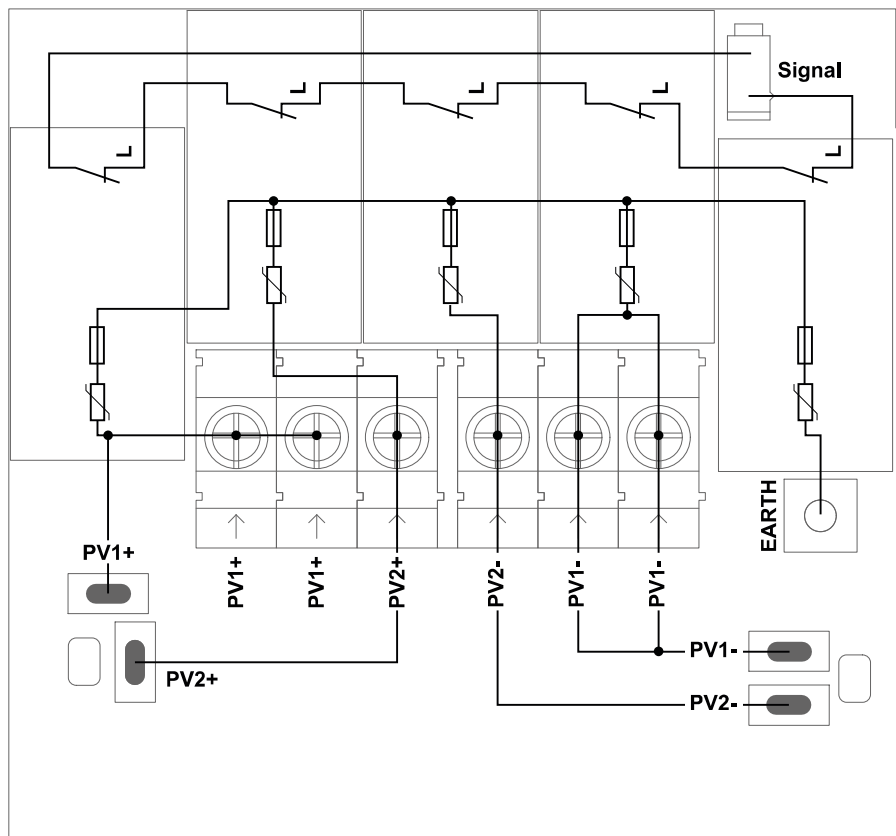



# **Dimensions of the inverter**

# Fronius Primo GEN24 3 - 6 kW

