



SELECTRONIC



Instruction Manual for
SP PRO
Interactive Inverter Charger

Installation • Operation • Service

Selectronic Australia Pty Ltd
© 2016

Suite 5, 20 Fletcher Rd
Chirnside Park VIC 3116
Australia
Ph +61 3 9727 6600
Fax +61 3 9727 6601

www.selectronic.com.au

Thank you for purchasing a Selectronic SP PRO series sine wave Interactive Inverter Charger optimised for either grid connected power systems (also called Solar Hybrid Power Systems) of Off Grid systems (no grid power available).

Selectronic has an accredited Quality Assurance system to AS/ISO9001-2008 covering both their manufacturing and design operations with over 25 years experience designing power conversion equipment for both domestic and industrial purposes.

As a result Selectronic has had many opportunities to listen to both integrators and system owners to determine their real needs.

We have learnt from our customers that:

- Modern solar energy systems need to do more than provide power when the sun shines,
- Inverters should be flexible. The one product should have a high rating on the power section that support's the mains grid and runs the customer's loads whilst the export power section has a lower power rating to comply with network export limits.
- Complexity should be a matter of choice. The inverter should be able to perform with the minimum of configuration but still be capable of integration into the most advanced energy system.
- Battery longevity is paramount. A combination of battery protection and the best charging parameters are essential.
- Monitoring / configuration software should be user friendly with intuitive "at a glance" menu clarity.

The SP PRO has been designed with these, and many other criteria in mind.

In addition to power conversion the SP PRO controls the operation of the entire energy system ensuring all sources of renewable energy are fully utilised whilst reducing the use of either grid power or generator power. The SP PRO is a complete Energy System.

Using the SP LINK simple Quick Start tool the SP PRO can easily be "hung on the wall" and work to suit many renewable energy installations or configure the advanced parameters to tailor the SP PRO to suit virtually any complex system requirements.

The default parameters provide safe and efficient charging for most common batteries along with provision to adjust for the individual battery manufacture's specifications.

SP LINK software program provided with the SP PRO has been designed with the user in mind. Need to get started quickly? Then use the SP LINK Quick Start. Need more in-depth customizing? Then use the logically laid out advanced configuration. Why was it ever difficult?

We are always interested in feedback about this document or the new SP PRO. Please do not hesitate to contact us via our web site www.selectronic.com.au.

When installed and maintained correctly the SP PRO will give many years of trouble free operation.





Contents



INTRODUCTION

Australian/New Zealand Warranty	6
Using This Manual	6
Included in this package	7
Glossary of Terms	7
Benefits of SP LINK	7
Solar Hybrid Support and Grid Feed Systems	8
Product Overview	8
Off Grid Stand Alone Power Systems (SPS)	9
Mobile Systems	9
Precautions and Safety	10
Who should install this unit	10
Protective Earth connection	10
Multiple Hazardous Energy Sources	10
Preparation	11
Installation	11
Maintenance	11
Inverter may start automatically	11
Backup Generator may start automatically	11
Battery	11

INSTALLATION

Installation-General Requirements	12
Environmental Considerations	13
Effects of altitude on the SP PRO	13
Preparation	14
Installation of SPMC models	15
Installation of SPLC models	18
Battery Cabling Requirements	21
Battery Fusing / Circuit Breakers	21
DC Wiring SPMC Models	22
Primary DC Terminal Connections - SPLC	22
DC Terminal Torque settings - SPMC and SPLC	22
DC Wiring SPLC Models	22
Expansion Card Warning - 120VDC model	23

Current Shunt Wiring	23
Battery Temperature Sensor	23
Battery Wiring (DC) Preparation	24
AC Wiring	25
Earth Wiring	25
Residual Current Device (RCD) Type	
Recommendation	26
AC Wiring Preparation	26
Backup Generator (Advanced Feature) Control	
Wiring	27
Serial Port Connection	27
Gland Plate Fit out	27
Initial Start up Procedure	27
Labelling	27

Installation-System Configuration 28

Managed AC Coupled Preparation	29
Generic AC Coupled Preparation	32
Three Phase Preparation	33
Split Phase Preparation	33
DC couple Charge Controller Preparation	34

Installation-Ancillary Components 36

Inputs and Output	36
External AC Source contactor	39
Adding a backup Generator (Solar Hybrid)	40
Adding a Generator (Off Grid)	41

Installation-Communications 42

Communications Overview	42
RS232 serial communications	43
USB communications	43
Wireless SP PRO to SP LINK	44
SP PRO Ethernet Adaptor	45
RS485 - Managed AC coupling link	45

Installation-Configure with SP LINK 46

Overview	46
Configuring The SP PRO For All System	
Configurations	47



Installation-Commissioning	48
Introduction	48
Diagnostics during Commissioning	48
Common System Checks	49
Checking Managed AC coupled systems	51
Checking Generic AC coupled	52
Checking DC coupled	52
Three phase and Split Phase Systems	53
External AC Source Contactor	54
External Generator	55

OPERATION

Controls and Indicators	56
User Interface	56
SP PRO Operation	58
Battery Management	59
Battery State of Charge (SoC) monitoring and control	59
Battery Voltage monitoring and control	59
Battery Charging Operation	60
Battery Charging Cycle	61
Battery Temperature Compensation	62
Renewable Management	62
Generator Controls for Off Grid	63
Backup Generator Controls (with option)	63
Inverter External Alarm	63

SERVICE

Service and Maintenance	64
Multiple Sources of Supply	64
Cleaning the Fan and Fan filter	64
Monitoring the Operation of the SP PRO	64
System Shutdown	65
Installer Maintenance of SP PRO	65
System Maintenance	65
Battery Maintenance and replacement	65
Troubleshooting	66
Front Panel Indicators	66
Troubleshooting with SP LINK	68
AC Power Problems	69
Battery Problems	69
Grid related Problems	69
Off Grid Generator Start/Stop Problems	70
Inverter Startup Problems	71
Resetting inverter with or without Restoring	71
Factory Default settings	71
Appendix A Specifications	72
Standards Compliance	72
Product Specifications	72



Australian/New Zealand Warranty

The Selectronic SP PRO product is warranted by the manufacturer to the original purchaser only. The manufacturer will bear the cost of parts and labour to repair any faults found within the terms and period of this warranty. For full warranty terms and conditions please see the warranty card packed with the SP PRO inverter.

If you have purchased the SP PRO outside Australia or New Zealand, please see the separate warranty supplied by the authorised distributor in your country.

Maximum warranty duration is given when the SP PRO is installed by a Selectronic Accredited Integrator and warranty registration is carried out on-line at www.selectronic.com.au

Selectronic Australia shall be under no obligation to warrant any equipment which has been improperly installed, stored, or handled, or which has not been operated or maintained according to this manual, nor for any operating mistakes and consequences arising from them.

Using This Manual

While every attempt has been made to ensure this manual is as self explanatory and clear as possible, there are some technical issues and safety warnings that require thorough understanding. It is extremely important that the owner and integrator/installer follow all of the instructions set out in this document; failure to do so may void the warranty and not give the full benefits that this product can provide.

This manual is divided into four sections to allow fast access to relevant information. The heading on each page indicates the section.

INTRODUCTION	This section, which provides a brief overview of the SP PRO including information about warranties and terms used in this manual.
INSTALLATION	Contains information relevant to the installers from unpacking the unit to configuring the settings of the SP PRO using SP LINK interface software. Also see the SP LINK manual (contained in the SP LINK software) for Configuration Settings and Monitoring details
OPERATION	Information relevant to the user and covers the day to day operation of the SP PRO as well as certain safety warnings. This section presumes the unit's installation and set up is complete and correct.
SERVICE	Provides information to service personnel in regards to preventative maintenance and troubleshooting in case of a fault.

A PDF copy of this manual may be downloaded from the Selectronic web site www.selectronic.com.au and is also included within the Help menu of the SP LINK software.

Throughout the manual the following symbols will be repeated. These symbols are very important.



This symbol indicates danger. Failure to observe this warning may result in serious injury or death, loss of property or damage to the power system



This symbol is used to draw attention to information that will assist in making full use of the system or gives notice to information which may not seem immediately apparent



Included in this package

- Mounting bracket
- Rear Outlet Mesh Cover (SPLC models only)
- Contents check list, checked and signed by Selectronic
- Know Your SP PRO display quick reference card
- Warranty card.
- Tool kit - (Hex Drive bits - T10 Torx, T20 Torx, T25 Torx, 5 mm Hex, 6 mm Hex, long extension)
- SP LINK software, this manual and helpful information packaged on USB Memory device
- USB Cable - Type B

Glossary of Terms

DC Coupled system	Where the Solar is connected to the DC side of the inverter system through a Solar Controller.
AC Coupled system	Where the Solar is connected to AC Side of the inverter system via a separate Grid Tie inverter.
Solar Hybrid	A battery based system that is connected to the electricity grid
Off Grid	A battery based power system that is remote from the electricity grid
AC Source	The primary AC input that is connected to the SP PRO, e.g., Mains Grid or Auto start Backup Generator.
Site File	An SP LINK file that is set up for each SP PRO inverter to be connect to.
Configuration File	Contains all the settings to be loaded into the SP PRO. This is normally linked to a site file
Solar Array	A collection of Solar Panels.
PV	Photo Voltaic solar power
State of Charge	(SoC) Referring to the battery charge condition. 100% SoC means a full battery.
Sealed Battery	A lead acid battery with no access to the electrolyte - either valve regulated or gel. No hydrogen gas discharge during normal operation.
Flooded Battery	A lead acid battery with access caps for maintaining the electrolyte - replacing water lost during recharge operations. Hydrogen gas discharged during normal recharge
Lithium Battery	A battery based around lithium technology. An example is Lithium Iron Phosphate (LiFePO4)
Aquious Battery	A battery with salt electrolyte such as the Aquion brand of battery.
SoC	State of Charge is the amount of charge in the battery bank expressed as a % of the battery capacity. When SoC = 100% the battery is fully charged. When the SoC is 50% then the battery is half charged.

Benefits of SP LINK

Provided with the SP PRO inverter is a free copy of the SP LINK software, a convenient configuration and monitoring tool used for integrating the SP PRO into the energy system.

SP LINK accesses a host of monitoring and logging features in the SP PRO to allow the user and installer to keep an eye on the system performance.

A PC running SP LINK is simply connected to the SP PRO via a USB port to open up the full potential of the SP PRO Energy System



Product Overview

Chapter One



The SP PRO Sine wave Interactive Inverter Charger is designed specifically for either Solar Hybrid (grid support / grid feed) or Off Grid (no grid available) systems to simplify their installation and configuration.

As a battery based inverter, charger and system controller all in the one product. each SP PRO has a configurable export power limit suitable for many export limited Solar Hybrid applications.

With its in built generator controller the SP PRO is also the ideal choice for all Off Grid installations.

The SP PRO is compatible with virtually any DC renewable charging source (such as a DC solar controller). Also any AC renewable source (such as a grid tie inverter) is compatible with the SP PRO in a Solar Hybrid system without limited export power..

For Off Grid Systems or Solar Hybrid systems requiring export limiting the Selectronic Managed AC Coupling must be used. Its advanced features include the precise control of compatible grid tie inverters to control Off Grid charging or the required export limit.

Solar Hybrid Support and Grid Feed Systems

In Solar Hybrid, the renewable energy can be directed to power the AC load, recharge the battery bank and/ or export to the grid. The direction and priority of the energy flow can be varied dependant on the time of

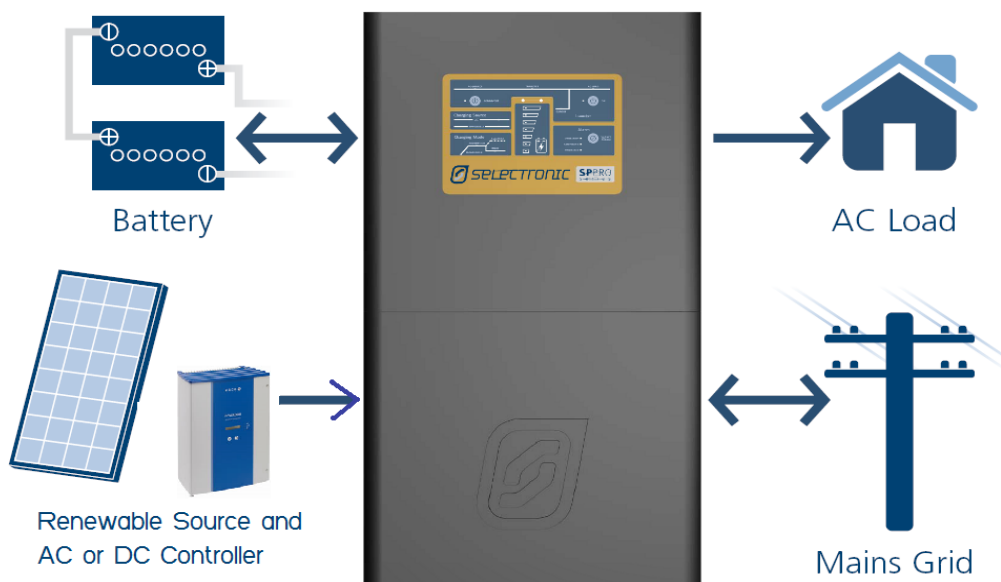



day, battery SoC or load demands allowing the maximum use of the renewable energy (such as PV solar) and stored battery energy to supply loads to take advantage of variable electricity tariffs. A Solar Hybrid system will allow the user to only use grid electricity when they choose.

By using the optional “Grid fail - Gen backup” module the SP PRO can be configured to automatically start and stop a generator during a prolonged power outage. When the generator is running, the SP PRO will use the generator to power the site load plus use any additional generator capacity to charge the batteries.

Off Grid Stand Alone Power Systems (SPS)

The SP PRO is the heart of the power system. It quietly provides AC power from the battery bank and renewable sources. By using SP LINK the SP PRO can be configured to monitor battery state of charge and load conditions to automatically start and stop the generator as required to charge the batteries and supply loads heavier than the SP PRO can efficiently handle. These features, when correctly configured, will increase the battery life and reduce generator running costs.

When the generator is running, the SP PRO will use the generator to power the site load; plus use any additional generator capacity to charge the batteries. When the site loads are greater than the generators output, the SP PRO will add its power to the generator. When the site loads are reduced, the SP PRO will return to battery charging. The above operation happens automatically, whilst always maintaining “no break” power to the site.

An SP PRO managed AC Coupled system is suitable for Off Grid systems due to the superior battery charging functions that are achieved by a sophisticated system control and monitoring communications link between the SP PRO and compatible grid inverters.

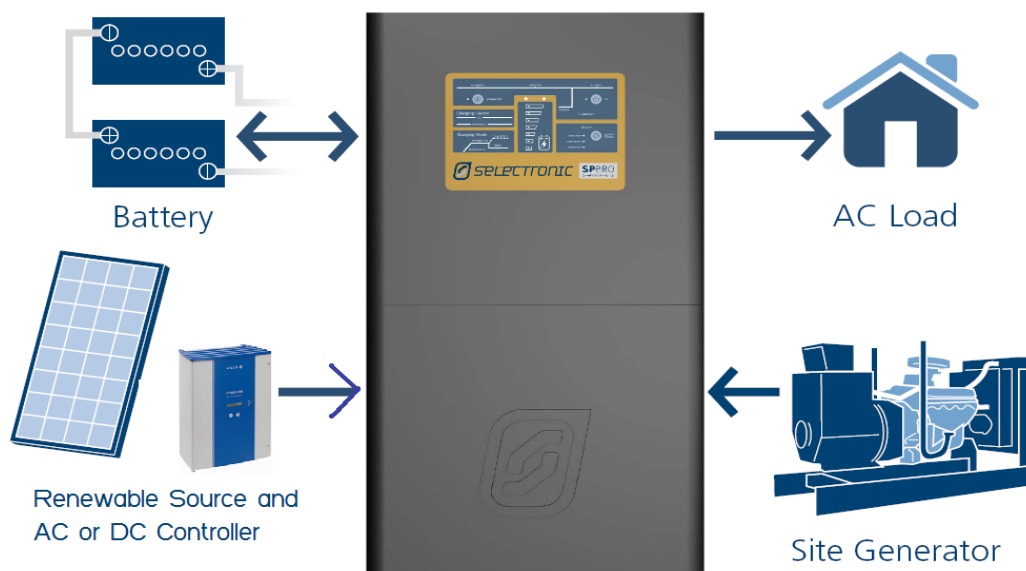

Mobile Systems

The SP PRO can support either an on board generator (Primary AC Source) or shore power (Alternate AC Source). Both input power levels can be configured into the SP PRO and selected with an external switch.



Precautions and Safety



Chapter Two



Warning: If this equipment is used in a manner not specified by the manufacturer as contained in this manual and other operational documents and Instructions, then the protection provided by the equipment may be impaired.

Who should install this unit

While the SP PRO is designed for easy installation and can be installed by any suitably qualified person, to maximize the performance of the system and tailor the configuration of the SP PRO to the specific needs we recommend the use of a Selectronic Accredited Integrator. These selected professionals within the industry have been extensively trained to analyse the system requirements, design ancillary equipment and have access to specialist support within Selectronic to assist with any individual requirements.

The voltages produced within a power system are hazardous. Even though the SP PRO may derive its input from a battery, the extremely high current capability of a battery bank is hazardous. Additionally the high voltage battery banks (120V) used in the SPMC1201, SPLC1200 and SPLC1202 are hazardous and the output and input AC voltage in all the SP PRO models is just as hazardous as grid electricity.

All AC connections and hazardous DC connections to the SP PRO must be carried out by a qualified Electrical contractor or similar, failure to do so will contravene legal requirements.

All DC wiring must be carried out by a person experienced with DC electrical circuits and must understand high current low voltage circuits. To ensure an efficient system installation, cable sizing and voltage drop must be understood and the recommendations within this manual followed.

Selectronic Australia shall have no obligation as to any equipment which has been improperly installed, stored, or handled, or which has not been operated or maintained according to this manual, nor for any operating mistakes and consequences arising from them.



This product is not to be used for Life Support equipment

Protective Earth connection



It is critical that all protective earth connections made within the SP PRO use the protective earth terminal. This is the earth terminal that is on the right hand side of the AC terminals and marked with a earth symbol enclosed in a circle.

Multiple Hazardous Energy Sources



Hazardous voltages and energy are generated by the SP PRO. They are fed into the SP PRO by external wiring from multiple sources and may be stored in capacitors after the SP PRO is switched off and disconnected from external wiring.



Preparation

Whilst every effort has been made to pack the SP PRO in a way that will provide adequate protection, damage in transit can occur. Please carefully check the packaging and the SP PRO for signs of damage and for all components mentioned in the “Included in the Package” section of this manual.

Please report any damage or missing parts to Selectronic or a Selectronic Authorised Distributor.

Please retain the original packaging for the safest and most effective method of repackaging if required.

Installation



- The SP PRO requires adequate ventilation, away from hot equipment. Do not obstruct the airflow passage of the SP PRO case (top and bottom). Ensure when installed in an enclosed space that there is adequate ventilation.
- The SP PRO must be located in a place away from electrolyte and corrosive aerosols.
- The SP PRO contains arcing contacts so must not be located near explosive gas mixtures such as hydrogen from batteries or diesel fumes.

Maintenance



Ensure that all energy sources are isolated before working on connected wiring. A backup generator may start or power may be restored by the SP PRO at any time. Never work on equipment or investigate a problem without following appropriate safety isolation procedures.

Inverter may start automatically



The SP PRO automatically starts and/or restarts and may restore power at any time. If a fault or overload is detected the SP PRO will shutdown and may automatically attempt to restart at varying intervals of up to several hours.

Backup Generator may start automatically



The SP PRO automatically starts and/or restarts a backup generator (when a Grid Fail - Gen Backup option is installed). If a fault or overload caused the SP PRO to shutdown then it will automatically attempt to start and restart the backup generator.

Battery



Batteries are very dangerous. Please read the safety information provided by the battery supplier.

- Battery acid is dangerous.
- Batteries can emit hydrogen gas, which is explosive.
- Batteries connected in series can produce hazardous voltages.
- Disconnecting a DC power connection (even on one battery cell) can cause dangerous high-energy DC arcs, which can cause serious burns and eject hot particles, and can be difficult to extinguish.
- Disconnecting a DC power connection (even on one battery cell) can cause renewable sources to produce large voltages (much larger than the battery voltage) on battery terminals and DC wiring. Such voltages can be lethal. They can also damage the SP PRO. Only suitably trained and qualified personnel should disconnect any DC power connection, including battery cell connections, and only with suitable procedures and safety precautions.
- System battery voltages of 60 V or greater are to be treated as a hazardous voltage.



Installation-General Requirements



Chapter Three



The SP PRO must only be installed by suitably qualified personnel. Many procedures covered in the INSTALLATION sections of this manual have inherent risks. Whilst the SP PRO is designed to be safe, including safety features never before found in an inverter (such as Earth / Neutral bond monitoring), the voltages connected to or generated within the SP PRO are hazardous and potentially fatal.



It is the responsibility of the installer to ensure the installation and all the wiring is carried out according to all safety standards that are applicable to the installation. The wiring diagrams and installation instructions are given as a guide only and compliance to appropriate standards is the responsibility of the installer.



The following section provides general installation instructions for the SP PRO . For information on specific configurations please refer to the “Installation-Specific Applications” Section in this manual and the relevant installation guide supplied with any required installation options.

All installation notes including this manual can be downloaded from the Selectronic web site at: www.selectronic.com.au



Environmental Considerations

ENVIRONMENTAL CATEGORY

The SP PRO is design with an Environmental Category (as defined by IEC 62109.1) for “Indoor, unconditioned. The SP PRO must be protected by a building or enclosure from direct rain, sun, wind-blown dust, fungus and radiation to the night sky.

The SP PRO must be installed in a dry environment.

POLLUTION DEGREE 2

The SP PRO is designed to operate in a Pollution Degree 2 environment. Normally only non-conductive pollution occurs with occasional temporary conduction due to condensation expected.

TEMPERATURE

The SP PRO is designed for an ambient operating temperature between -20°C and 60°C, with a storage temperature range between -20°C and 70°C.

AIR FLOW

For best performance ensure nothing impedes ambient air from being drawn in the bottom of the unit and that hot exit air is vented away and doesn't recirculate into the unit. Particular attention must be paid when installed inside a cabinet or enclosure.

CLEARANCE FROM OTHER EQUIPMENT

A recommended clearance distance of 150 mm around all sides, top and bottom. Particular care must be taken when mounting near other heat producing equipment.

HUMIDITY TOLERANCE

The SP PRO is designed to operate in a humidity range of 0 – 99% non condensing.

INGRESS OF PARTICLES

The SP PRO has been designed to meet IP rating 43 (Protected against solid objects larger than 1.0 mm / protected against water falling as a spray at up to 60 degrees from the vertical).

Effects of altitude on the SP PRO

Altitude (m)	Derating Factor @ 40°C
0, sea level	1.00
1000	0.95
1500	0.90
2000	0.85

The power rating of the SP PRO should be compensated for the effects of altitude by applying the appropriate derating factor. For example, at 2000 m above sea level, 6 kW x 0.85 = 5.1 kW. The altitude compensated rating is still at 40°C.



Preparation

The selection of a suitable site and good preparation is essential in getting optimum performance from the SP PRO.

SP PRO Inverter performance is dependant upon the environmental operating conditions, in particular ambient temperature and ventilation. In addition safety aspects must be considered, such as:

- Restrict access to authorised personnel only.
- Consideration of maintenance of ambient temperatures to ensure performance within product specification.
- Positioned away from heat producing devices such as generators.
- Adequate ventilation, adhering to the minimum clearances required for adequate heat dissipation.

Minimum 150 mm clearance from top, bottom and sides.

- In a covered location away from direct rain. The SP PRO has an environmental rating of IP43 which makes it unsuitable for water spray that is greater than 60 deg from the vertical or greater than 0.7 litres per minute.
- In a location shaded from direct sunlight.
- Away from any explosive gas.
- Rodent Proof.
- In a clean environment away from dust, iron filings, workshop pollutants and other small particles.
- Enough room to remove the cover.
- The provision of infrastructure for monitoring - example data cables

The SP PRO should be installed in a separate area to the battery system (where used). The battery bank can emit explosive gas(hydrogen) and this must be vented outside and away from the SP PRO. The battery system should not be accessible by the user.

When batteries are used in the system it is recommended that the installation be in lockable area with a separating partition or enclosure for the battery bank.

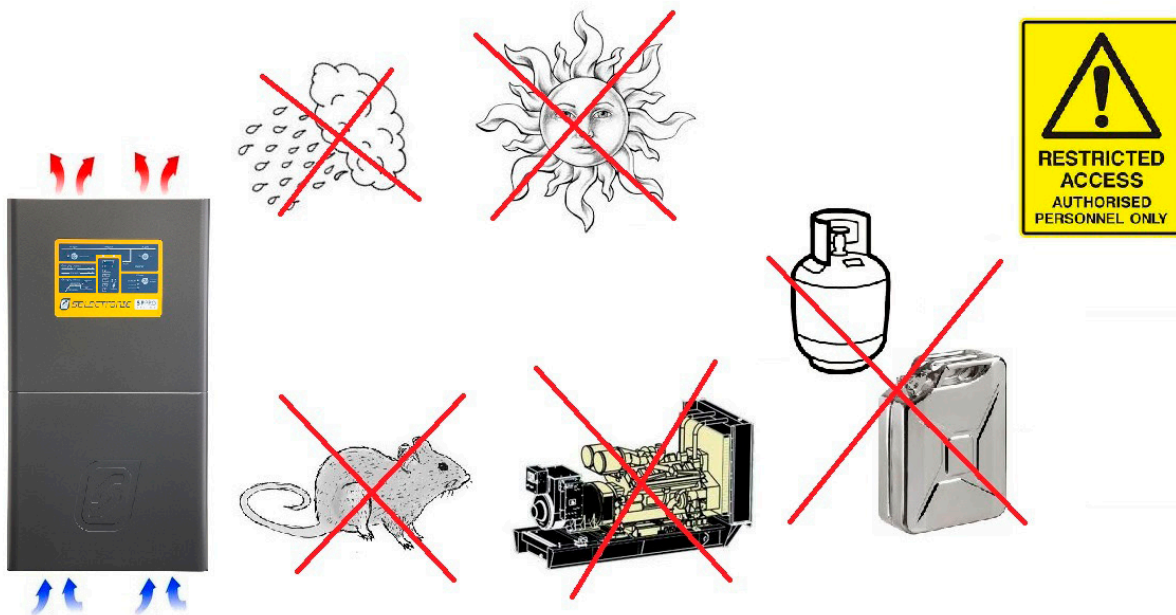



Installation of SPMC models

1 - Unpack the SP PRO onto a flat surface. When removing the SP PRO from its packaging carefully inspect for any damage that may have occurred in transit. Damage must be reported to the supplier immediately.

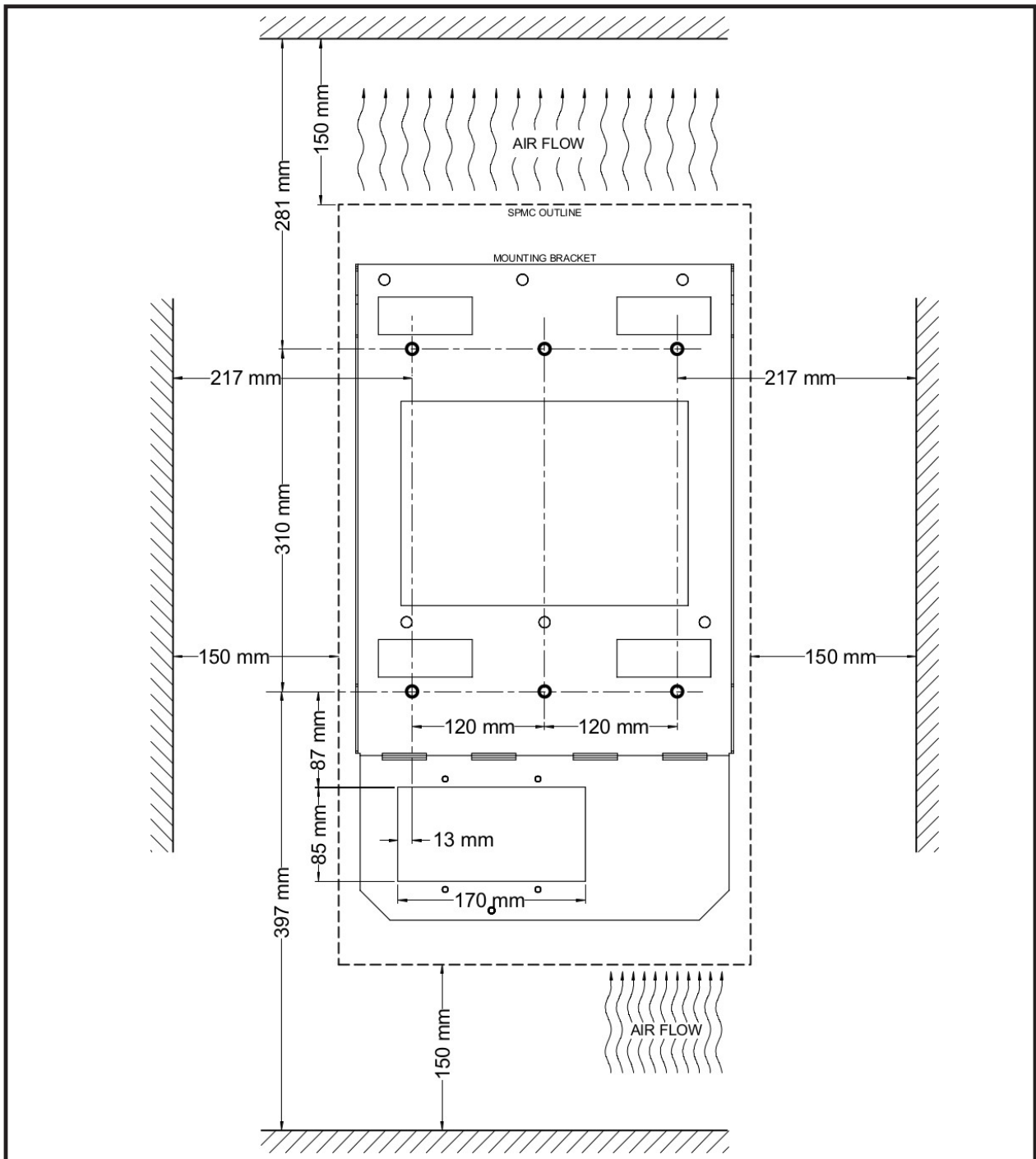
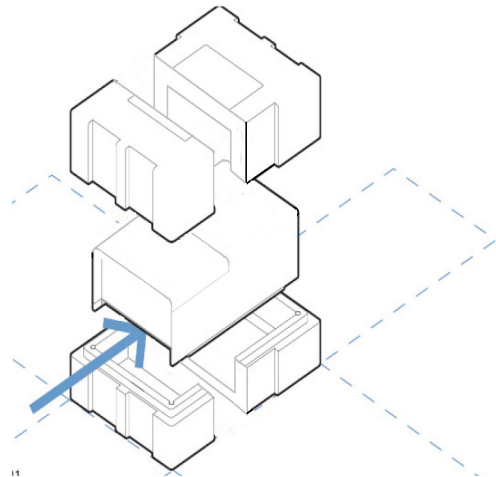



2 - Diagram previous page. Choose a suitable weight bearing and temperature resistant surface to mount the SP PRO. Mounting **MUST** be to solid timber studs, solid timber, brick, masonry or other load bearing wall. **DO NOT** mount directly to plaster. Max temperature is ambient +30 degrees C, max weight is 45 kg. The display of the SP PRO should be at eye level. There should be no obstructions to the clear passage of air. Use the 6 x M8 holes to mount the bracket. If the SP PRO is being installed in a mobile situation use the optional mobile mounting bracket.

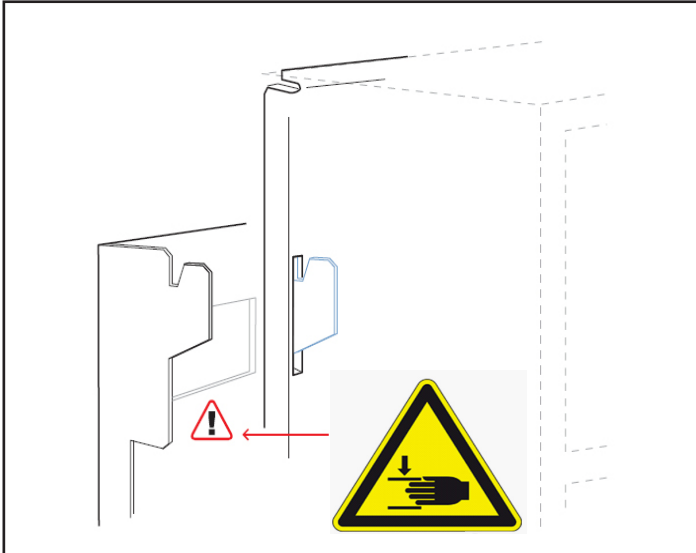

3 - Leave access cover (A) in place. Lift inverter from underneath whilst stabilising top. Inverter is top heavy and gloves must be worn. Mount the SP PRO on the mounting plate by first hooking the top of the inverter over the projections and lowering it into position. Care should be taken to observe Pinch Point warning.

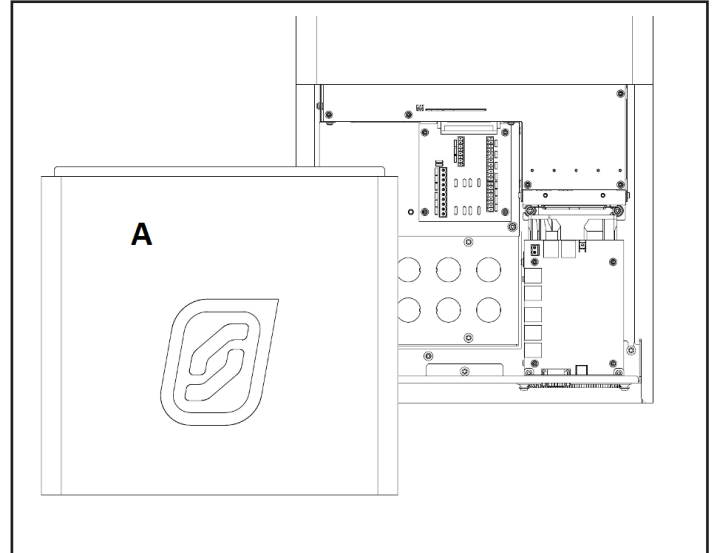

4 - With a T25 torx driver, remove the access cover(A) by unscrewing the two M5 Torx screws at the bottom of the SP PRO.

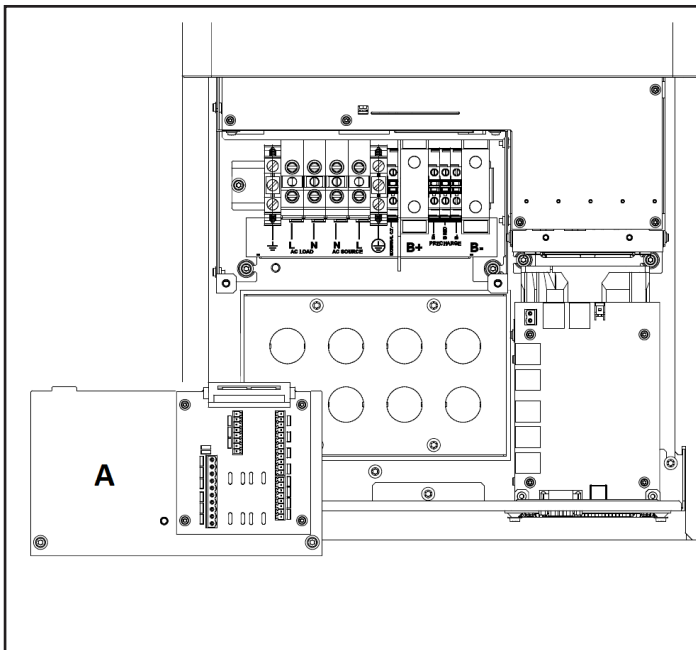

5 - Using the T20 torx driver remove the terminal cover and expansion card(A) by undoing the 2 screws.

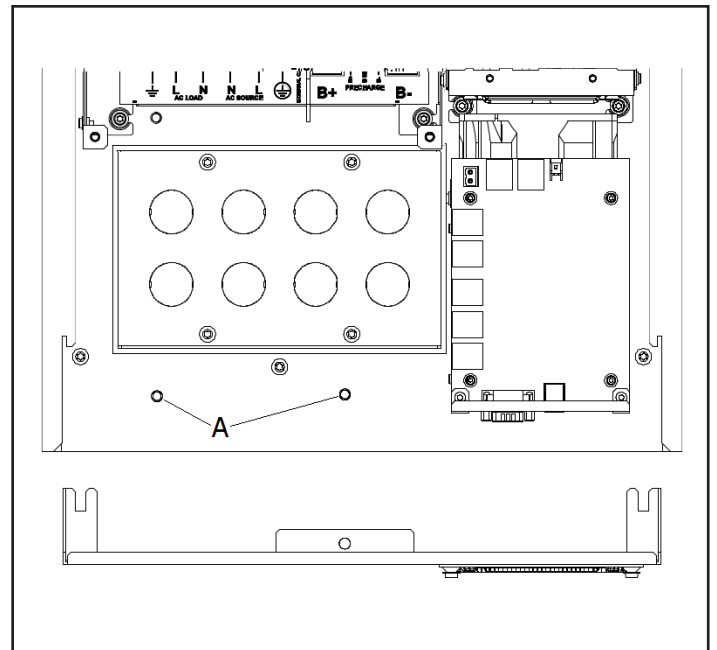

6 - The lower gland plate can be removed if required to give greater access to wiring terminals using T25 torx driver. NB, side screws need only be loosened. Secure the bottom of the SP PRO to the mounting plate with two M5 Torx screws. (A on above diagram)



7 - STOP: Detailed instruction for wiring SP PRO contained on the following pages. These **MUST** be followed before proceeding with installation.

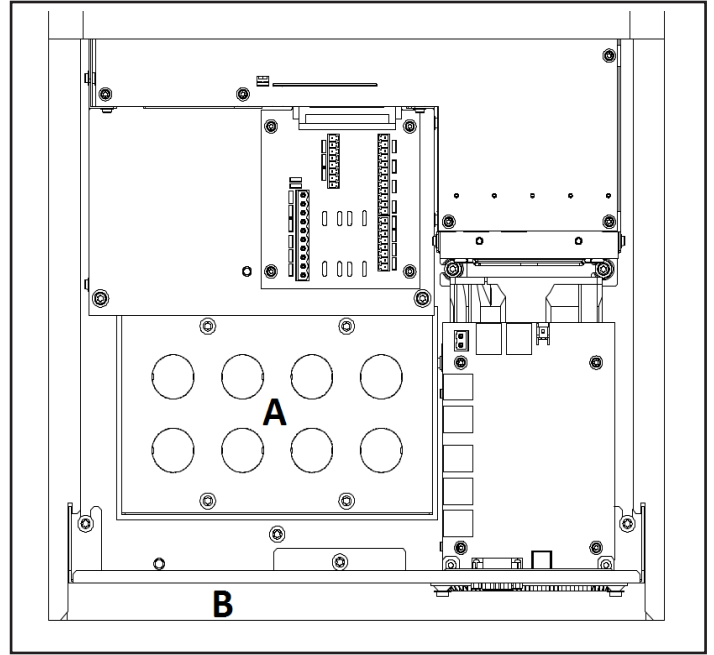
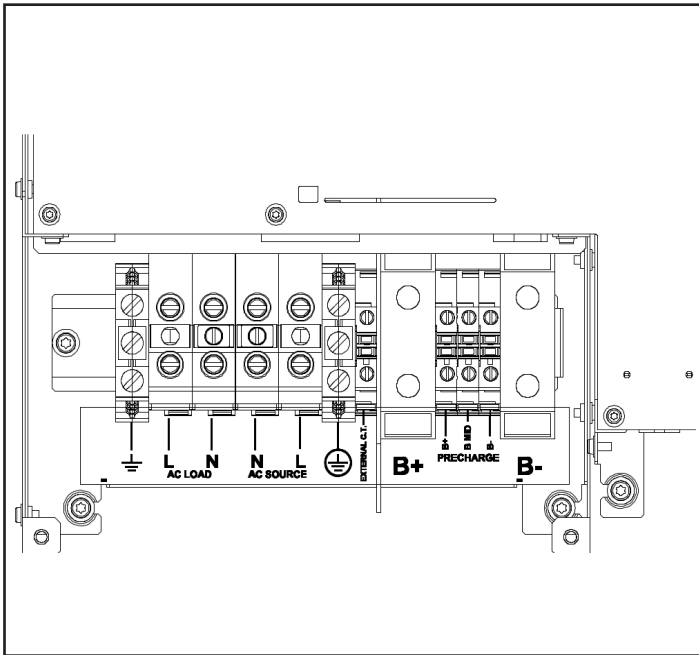

8- Wiring must only be carried out by suitably qualified installers and must adhere to all relevant standards.

Please bear in mind that installations performed and signed off by a Selectronic Accredited Integrator will benefit from additional warranty cover.

9 When all the AC wiring is complete reinstall the terminal cover and expansion card.

Important points

- Failure to fill any holes in rear gland plate (A) or lower gland plate (B) will reduce IP rating and compromise thermal design.
- Installation of the included battery temperature sensor is imperative for the correct and accurate charging of the batteries.



Installation of SPLC models

1 - Undo ten bolts ($\frac{7}{16}$ ") to remove lid on packing crate. Cardboard tray contains mounting plate, rear air outlet mesh cover and all documentation. Inspect for damage in transit and report any to the supplier immediately.

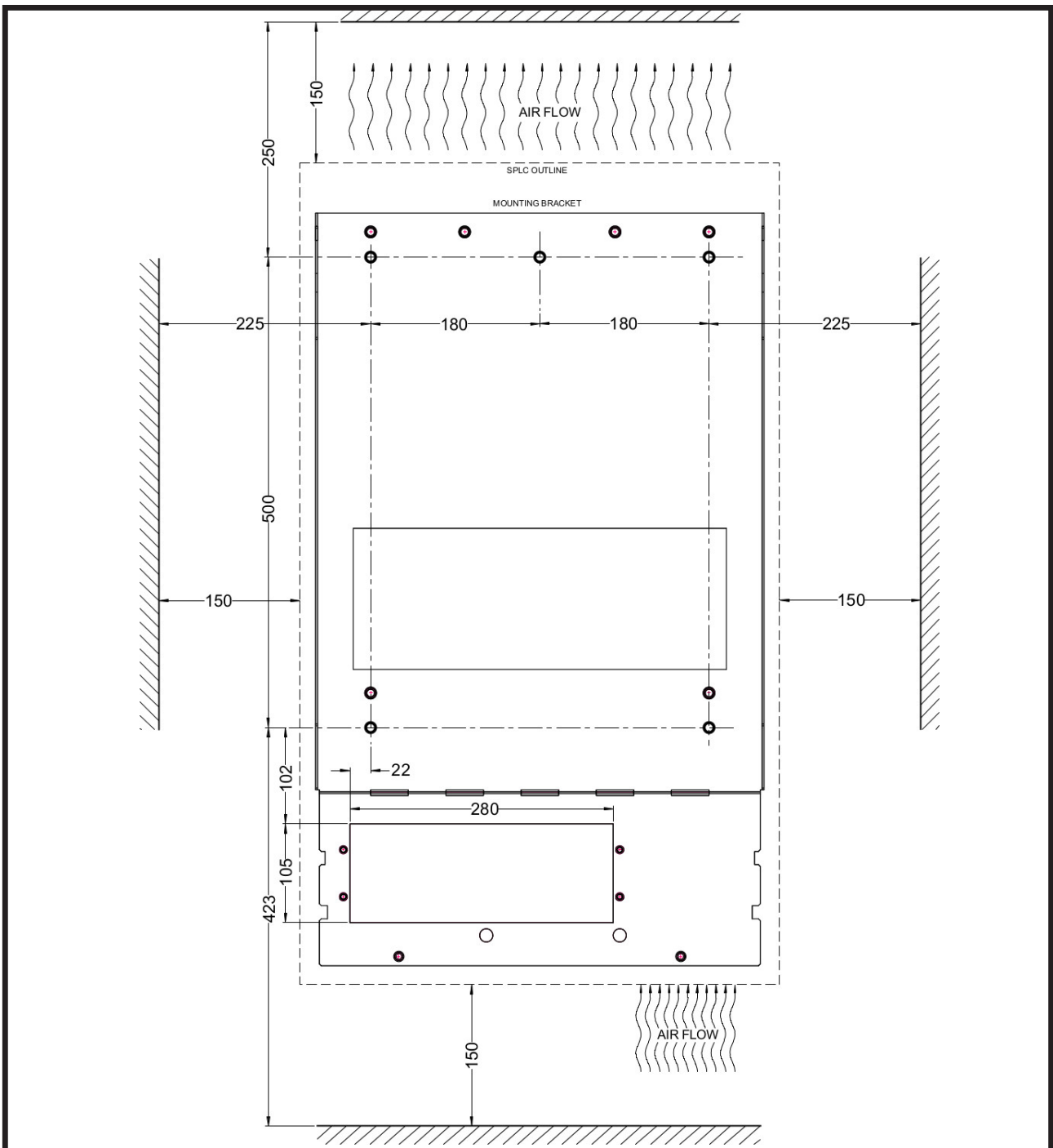
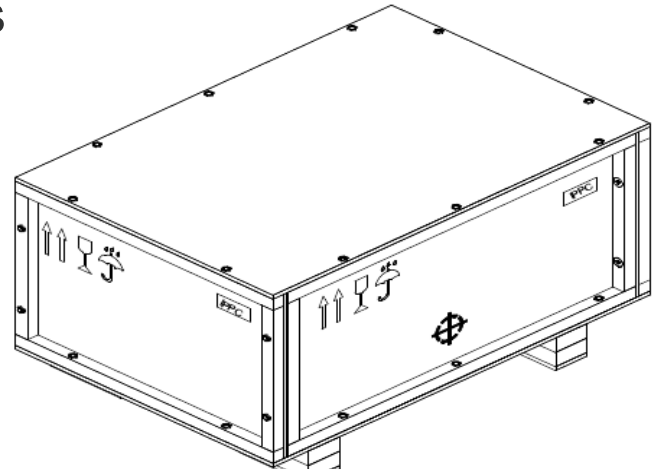

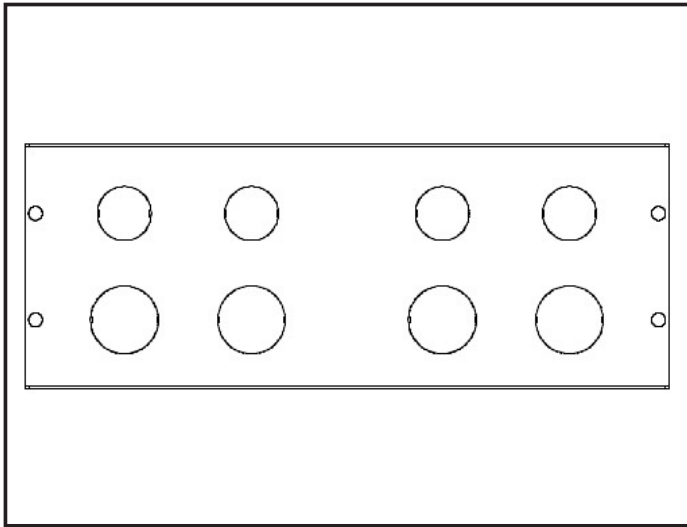

2 - Cable entry is either from below or wall entry. Gland plates are interchangeable. Gland plates secure to the underside of unit base or to the inside of the mounting plate using four T25 Torx screws.

3 - See Diagram on previous page

Choose a suitable weight bearing and temperature resistant surface to install the mounting plate. Mounting **MUST** be to solid timber studs, solid timber, brick, masonry or other load bearing wall. **DO NOT** mount directly to plaster. Max temperature is ambient +30°C, weight is 115 kg. The plate should be mounted at a convenient level.

There should be no obstructions to the clear passage of air.

Wall or cavity cables may now be fitted through gland plate.

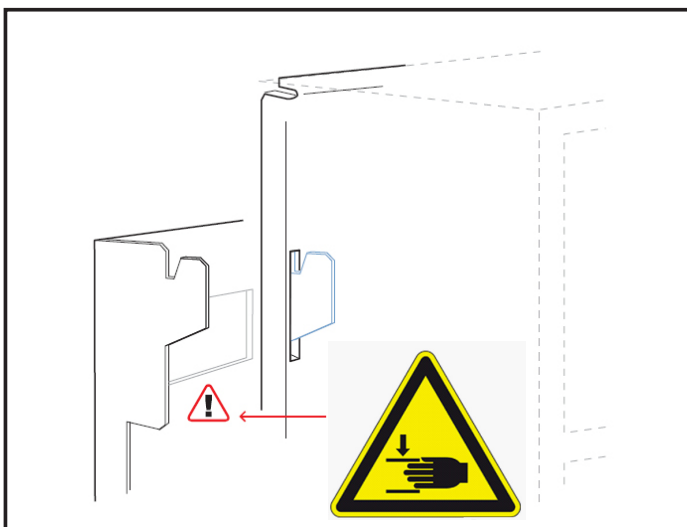

5 - Mount the SP PRO on the mounting plate by first hooking the top of the inverter over the projections on the mounting plate and lowering it into position. Care should be taken to observe Pinch Point warning. Secure the bottom of the inverter to the mounting plate with two M6 bolts provided.

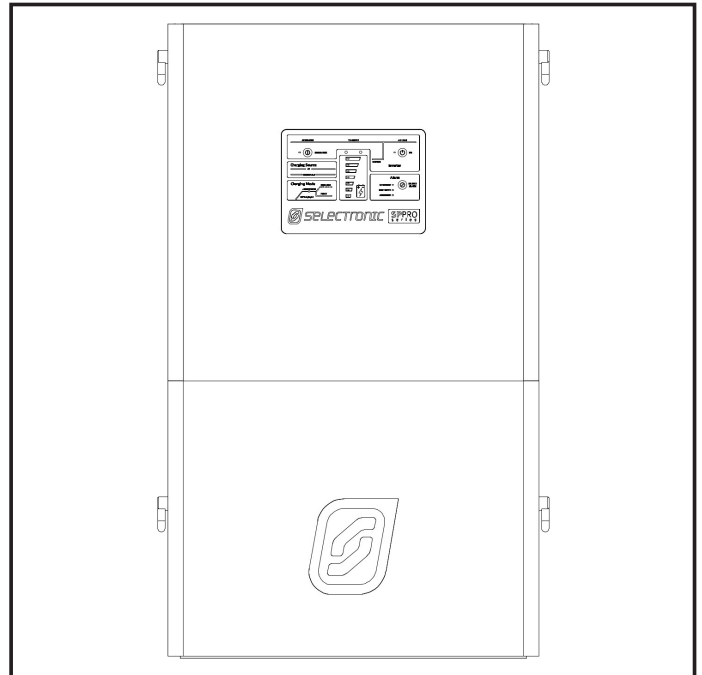

4 - Undo 10 bolts ($7/16"$) to remove sides from the packing base. Undo 8 bolts ($7/16"$) to remove clamps from handles. **DO NOT** remove front access cover.



HEAVY: Take care when lifting - 105 kg
SHARP: Use gloves - handle edges sharp.
TOP HEAVY: Secure unit when standing unit upright.

Stand unit upright using handles.

REAR AIR OUTLET MESH COVER: Fit and secure with six thumb screws

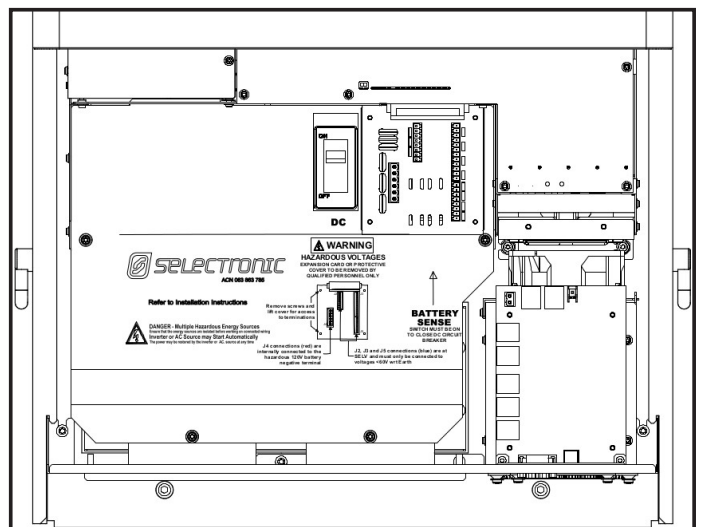

6 - Using T25 Torx driver remove the cover by unscrewing two screws at the bottom of the SP PRO.

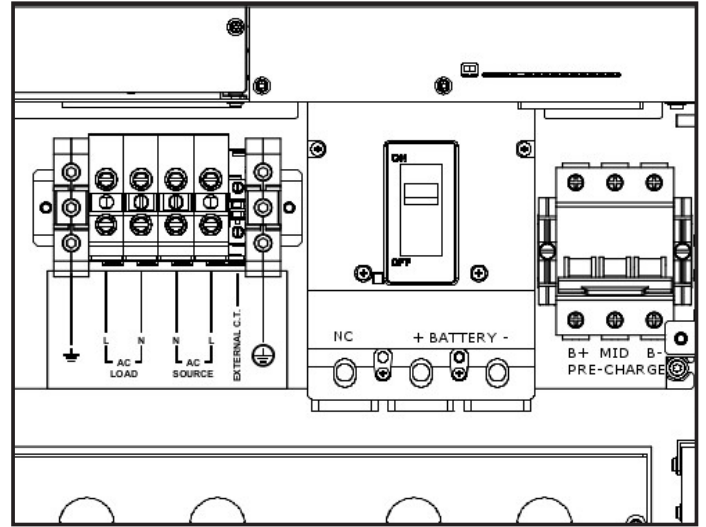
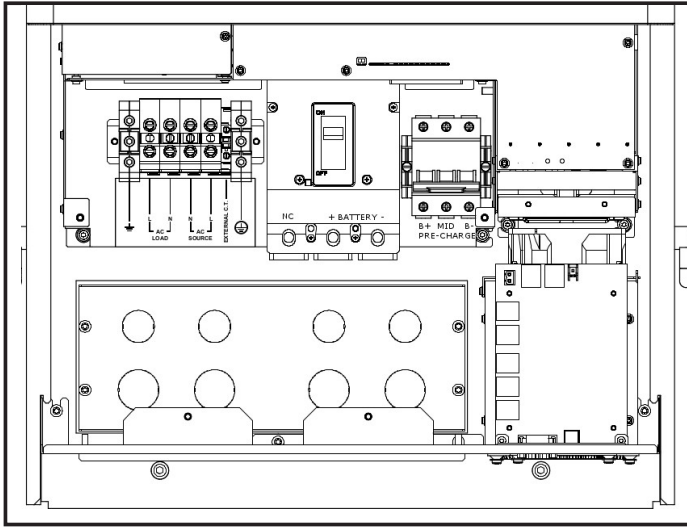

7 - Undo five T20 Torx screws to remove terminal plate. Expansion card remains secured to SP PRO.

Note: Expansion card not shown for clarity.
Note: Gland plate shown in wall entry cable position.



8 - Wiring can only be carried out by suitably qualified installers and must adhere to all relevant standards.

Installations performed and signed off by a Selectronic Accredited Integrator will benefit from an additional warranty cover.



9 - STOP: Detailed instruction for wiring SP PRO contained on the following pages. These MUST be followed before proceeding with installation.

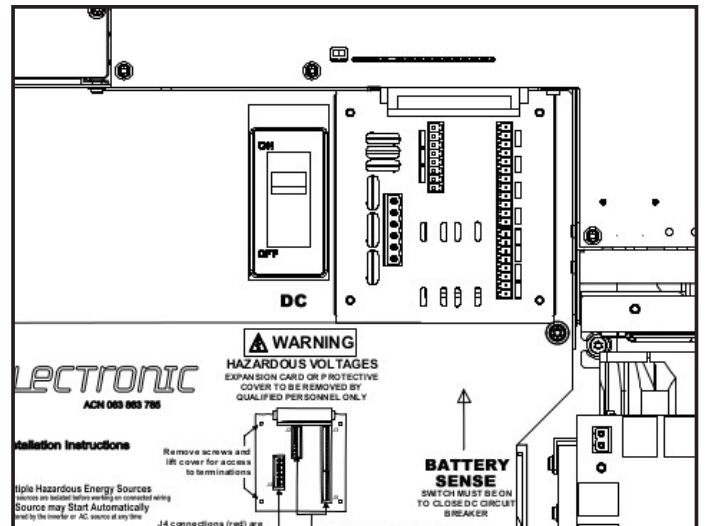
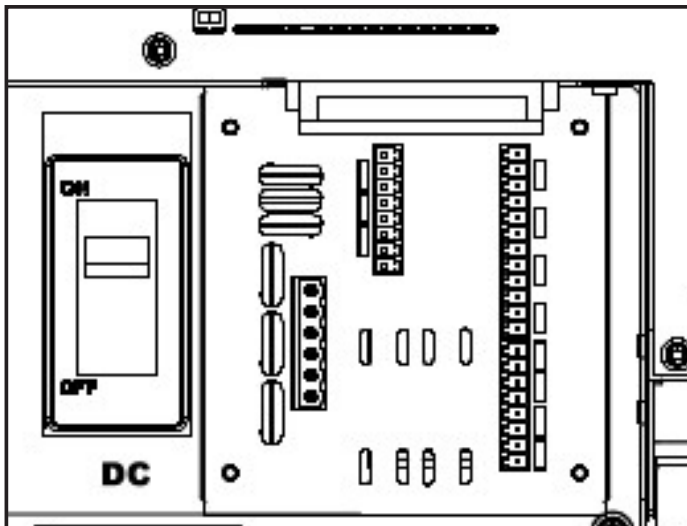

10 - Important points



- Failure to fill any holes in the gland plates will compromise IP rating and the thermal design.
- Protective cover on Expansion Card MUST be fitted.
- Installation of the battery temperature sensor is imperative for the correct and accurate charging of the batteries.

11 - Initial Switch On.

- Verify all connections are tight and correct polarity.
- Battery Sense / pre-charge switch (under Expansion Card) must be closed and pre charge complete before DC Breaker will close.



Battery Cabling Requirements

The follow tables specify the minimum Recommended Copper Battery Cable Sizes for SP PRO GO inverter.

NOTE: Please ensure the battery cabling and the fusing complies with relevant safety standards.

Total distance per conductor from the SP PRO to the battery terminals	Minimum Size Copper Battery Cables per inverter. Based on cable loss < 2% (V90 OR V-90HT INSULATION)					
	SPMC240	SPMC241	SPMC481	SPMC482	SPMC1201	SPLC1200, SPLC1202
< 2 m	50 mm ²	70 mm ²	50 mm ²	50 mm ²	35 mm ²	50 mm ²
2 - 5 m	70 mm ²	50 mm ² x 2	50 mm ²	70 mm ²	35 mm ²	50 mm ²
5 - 10 m	N/A	N/A	70 mm ²	70 mm ² x 2	50 mm ²	70 mm ²
> 10 m	N/A - NOT RECOMMENDED					
Battery Sense/Pre-charge	1.0mm ² or greater, double insulated (see note)					



V90 or V-90HT insulated cables are required to be spaced apart by at least the diameter of the cable. For cables with higher grade insulation, no spacing is required. The maximum temperature rating of the cabling within the unit needs to be considered. Maximum temperature with cabling space is ambient +30 degrees C.



In a multi phase installation, the total battery cable rating is multiplied by the number of inverters in the system. For example in a three phase installation using three SPMC482 inverters, the minimum battery cable size with a length of 2m - 5m is 3 x 70 mm² or equivalent



Failure to follow cable size recommendations will reduce inverter performance to the published specifications due to excessive voltage drops
Battery Sense / Pre-charge cable MUST be robust with solid insulation. DO NOT USE CAT5 or equivalent cable.

Battery Fusing / Circuit Breakers

Recommended Battery Fuse or Circuit Breaker Sizes per SP PRO inverter.



The following recommendations MUST be adhered to for correct system operation. Failure to follow the fuse / circuit breaker recommendations WILL lead to loss of power.

Product	SPMC240	SPMC241	SPMC481	SPMC482	SPMC1201	SPLC1200, SPLC1202
Battery fuse / Circuit breaker Rating per inverter (A)	250	250	160	250	160	250
Battery Sense/Pre-charge	2A or greater (sized to protect wiring)					



The DC Breaking Capacity (normally specified in kA at a maximum DC voltage) of the fuse or circuit breaker must be greater than the maximum DC Short Circuit current for the sites connect battery system.



In a multi phase installation, the total battery fuse / circuit breaker rating is multiplied by the number of inverters in the system. For example in a three phase installation using three SPMC482 inverters, the battery fuse size is 3 x 250A = 750A.



DC Wiring SPMC Models



WARNING: Copper wiring must be used through out..
Observe polarity of ALL battery wiring. Reverse battery polarity will cause irreversible damage.

All the SPMC models do NOT contain an internal fuse or DC breaker. The DC wiring must be fitted with appropriate fusing or circuit breakers.

The fuse or circuit breaker must be located in a user accessible position and be in close proximity to the battery system. The battery system must not be accessible by the user.

There are four DC wiring connections that should be made. B+ and B-, Battery Sense / Pre Charge and optional MID point monitoring. The battery sense / pre-charge connections can be made with light duty cable (1.0 mm² or greater).

DC wiring should be fed through the appropriate gland and terminated into the correct terminals. Connect the battery negative lead with the insulation stripped back 28 mm to the SP PROs Battery Negative screw terminal. Tighten the hex screw with the driver provided. Repeat the same process with the positive battery lead. Ensure that NO part of the wiring insulation is clamped in the SP PRO battery terminals.

Primary DC Terminal Connections - SPLC

M8 copper lugs are required to connect battery wiring into the SP PRO. SPLC1200 and SPLC1202 models only (All SPMC models are fitted with tunnel terminals for all the DC terminations)

Some brands of 70 mm² lugs may need to be reduced in width to fit within circuit breaker terminal.

DC Terminal Torque settings - SPMC and SPLC

SPMC Main DC Terminals	SPLC Main DC Terminals	SPMC & SPLC Pre-charge terminals
6.0 to 7.0 Nm	10 to 12 Nm	1.2 to 1.4Nm

DC Wiring SPLC Models



WARNING: Copper wiring must be used through out..

The SPLC1200 and SPLC1202 models contain a 250 A DC circuit breaker and a low current Battery Sense / Pre charge DC switch. It may be necessary to fit additional fusing or circuit breakers to protect the battery system. Any additional fuse or circuit breaker must be located in a user accessible position and be in close proximity to the battery system. The battery system is hazardous and must not be accessible by the user.

DC wiring should be fed through the appropriate gland and terminated to the correct terminals.

Battery B+ and B- connections. Connect the battery negative lead using M8 copper lug to the SP PROs B- terminal. Tighten the hex screw including load washer with the 6 mm Allen key such that load washer flattens. Repeat the same process with the positive battery lead. The terminal labelled "NC" provides no internal connection.

Battery Sense / Pre charge B+ and B- and optional MID connections. These connections can be made with light duty cable (1.0 mm² or greater) - cable MUST be double insulated. Connect the battery negative lead with the insulation stripped back 12 mm to the SP PROs Pre charge negative screw terminal. Repeat the same process with the positive battery lead and optional mid point lead.



Multiple Hazardous Energy and Voltage Sources

DC wiring is fed from multiple sources including internal capacitors. Care must be taken to ensure that under no circumstances can the user access or touch wiring even after the operation of external circuit breakers or fuse assemblies.

SPMC1201, SPLC1200 and SPLC1202 models operate from a hazardous DC voltage (120VDC). Care MUST be taken to ensure users cannot come in contact with the DC supply.



Expansion Card Warning - 120VDC model



SPMC1201, SPLC1200 and SPLC1202 models - Hazardous Voltage - 120 V Battery

Expansion card connects to both Hazardous and Safety Extra Low Voltage (SELV) wiring. The connector and wiring to J4 (marked with RED on card) MUST be treated as Hazardous and be physically segregated from other wiring connected to expansion card.

Protective cover MUST be installed on the Expansion card.

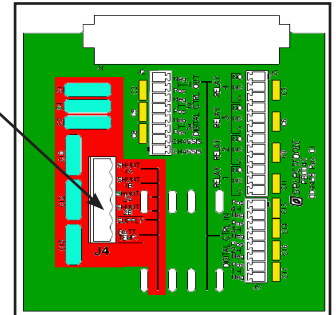

Current Shunt Wiring



SPMC1201, SPLC1200 and SPLC1202 models - Hazardous Voltage - 120 V Battery

Current shunts connections are both internally and externally connected to battery negative terminal and MUST be treated as Hazardous. Double insulated sense cabling MUST be used.



DC Shunts MUST be installed into the battery negative lead. Ensure that the shunt ONLY measures the renewable or other DC load current and not any current feeding to or from the inverter.

The sense wires for the externals shunts should be fed up through the appropriate gland and terminated to the SP PRO expansion card. The sense cabling should be kept as short as possible. "CAT5" type cabling or any multi conductor multi strand cable is suitable for shunt sense wiring. Remember that these small cables are connected to battery negative and an inadvertent short circuit with either lead to battery positive would short circuit the battery bank. It is recommended that both these wires be fused.

The polarity of these shunt sense leads is not important if they are configured to either "Load" or any of the input selections, such as "Solar"; however polarity is important when using the shunt in "Dual" mode – that is where the shunt is used for both input and output measurement to obtain a nett result.

In "Dual" mode, the sense leads must be connected correctly – expansion card shunt terminal 1A or 2A to the solar and load side, 1B or 2B to the battery negative side.

For More information please see "TN0045_03 SP PRO Shunt Installation" document available on the USB stick provided with this product or from www.selectronic.com.au

Battery Temperature Sensor



SPMC1201, SPLC1200 and SPLC1202 models - Hazardous Voltage - 120 V Battery

Battery temperature sensor is internally connected to battery negative terminal and MUST be treated as Hazardous. Sensor cable is double insulated.

The battery temperature sensor is pre-wired to the expansion card and must be installed in thermal contact with the centre of a side of a battery and insulated from external temperature effects for accurate charging. If the cable provided is not long enough it may be extended. Polarity of the cable is not important.

A small piece of the foam cut from the inverter's packing material (or similar packing foam) can be used to both wedge the temperature sensor in place and insulate it from external temperature effects (see insert below).



Battery Wiring (DC) Preparation

The below schematic diagram shows the main battery isolator, battery sense / pre-charge isolator and included temperature sensor.



For 48V and 120V battery banks it is a requirement that the Battery Sense / Precharge connections are used and wired directly back to the battery bank terminals. It is highly recommended that the Battery Sense / Precharge is used for 24V battery banks but if not then the SP PRO Battery S+ and S- terminals must be connected to B+ and B- respectively.

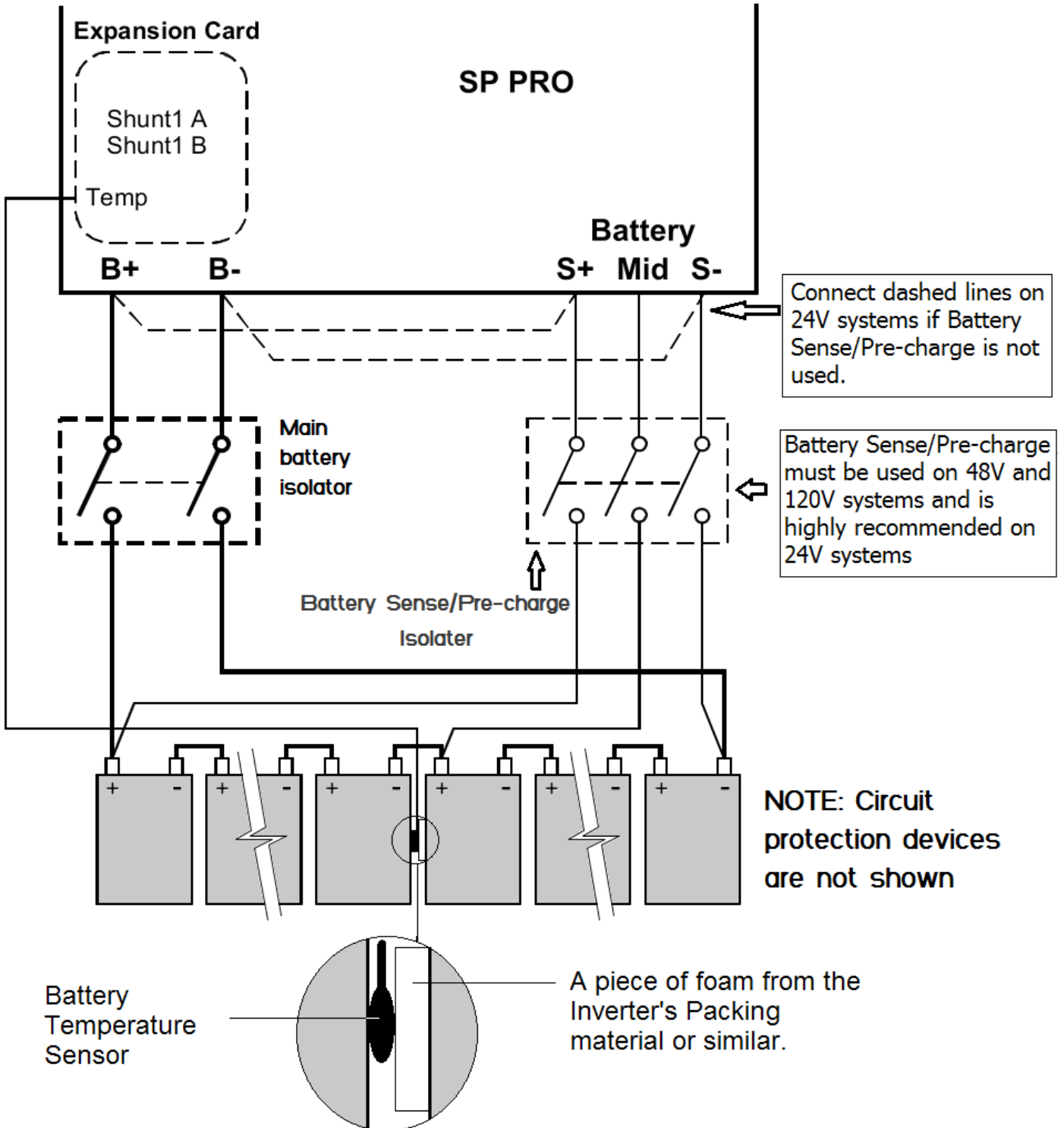

Diagram given as a reference only. Please ensure all wiring complies with relevant safety standards.



AC Wiring



The SP PRO is overvoltage category III meaning that it must be a fixed installation connected either downstream of (customer's side) or directly to the main switchboard.

WARNING: Copper wiring must be used through out..

The SP PRO does NOT contain internal circuit breakers or fuses. The AC wiring MUST be fitted with appropriate fusing or circuit breakers.

The AC cabling should be sized according to maximum demand through (consumed by the AC Load) and simultaneously consumed by the SP PRO (consumed by the charging of batteries). The SP PRO is fitted with terminals which are suitable for accepting up to 35 mm² (50 mm² for SPLC models) cables. The SP PRO is rated to 63 A (125A for SPLC models) current capacity and must be protected externally with circuit protection device(s) of no greater than this.

AC wiring should be fed up through the appropriate gland and terminated to the SP PRO. Connect the AC load wiring to the SP PRO: earth stripped back according to the table below. Connect the AC source wiring to the SP PRO: earth to the AC Source earth terminal, neutral and active to the AC Source terminals.



Multiple Hazardous Energy Sources

AC wiring is fed from multiple sources. Care must be taken to ensure that under no circumstances can the user access or touch wiring even after opening all circuit breakers.

Earth Wiring



It is critical that all protective earth connections made within the SP PRO GO us the protective earth terminal. This is the earth terminal that is on the right hand side of the AC terminals and marked with a earth symbol enclosed in a circle.

The inverter shall be earthed to the installations Earth system. A minimum copper earthing conductor not less than the table below, shall be used. See the local regulations for further information on earthing conductor size.

Earth the inverter by connecting earth wiring from the switchboard to the inverter Earth terminal. The SP PRO is suitable for Multiple Earth Neutral systems.

	Cable and CB sizing for AC wiring - SP PRO					
	SPMC240	SPMC241	SPMC481	SPMC482	SPMC1201	SPLC1200, SPLC1202
Maximum AC CB rating	63A	63A	63A	63A	63A	125A
AC Terminal size	35 mm ²	35 mm ²	35 mm ²	35 mm ²	35 mm ²	35 mm ²
Strip length for AC terminals A and N	18mm	18mm ²	18mm	18mm	18mm	18mm
Strip length for Earth terminal	12mm	12mm	12mm	12mm	12mm	16mm
Min. Earth cable size	6 mm ²	6 mm ²	6 mm ²	6 mm ²	6 mm ²	16 mm ²
Terminal Torque settings	6.0-7.0 Nm	6.0-7.0 Nm	6.0-7.0 Nm	6.0-7.0 Nm	6.0-7.0 Nm	6.0-7.0 Nm

Table given as a reference only. Please ensure all wiring complies with relevant safety standards.



Residual Current Device (RCD) Type Recommendation

The SP PRO produces a low distortion sine wave output via 50/60 Hz isolation transformer. This topology ensures that the output is sinusoidal and that there is no DC component associated with the SP PRO AC supply, whether that be feeding a domestic load or exporting solar to the grid. Standard Type AC RCDs are suitable for use with an SP PRO. Other types of RCDs may also be used.

AC Wiring Preparation

The intended application and use of the SP PRO must be well understood to allow the SP PRO to be appropriately connected to the installation. How the SP PRO is wired into the switchboard is dependant on whether all the installation's loads or only essential loads are to be supplied by the SP PRO for tariff optimization, self consumption or battery backup.

The below diagram shows AC wiring only and indicates the customer circuits; some of which are battery back-up protected, some are grid supply only.

Attention must be paid to the Neutral conductor and connection through to the loads. The neutral conductor connecting to the loads must be maintained such that operation of the inverter isolator would not alter the bonding between Neutral and Earth.

The Neutral conductor must remain connected through to the loads and particular care should be taken with the placement of RCDs. These devices open both Active and Neutral conductors thus the SP PRO must be installed on the grid side of these devices.

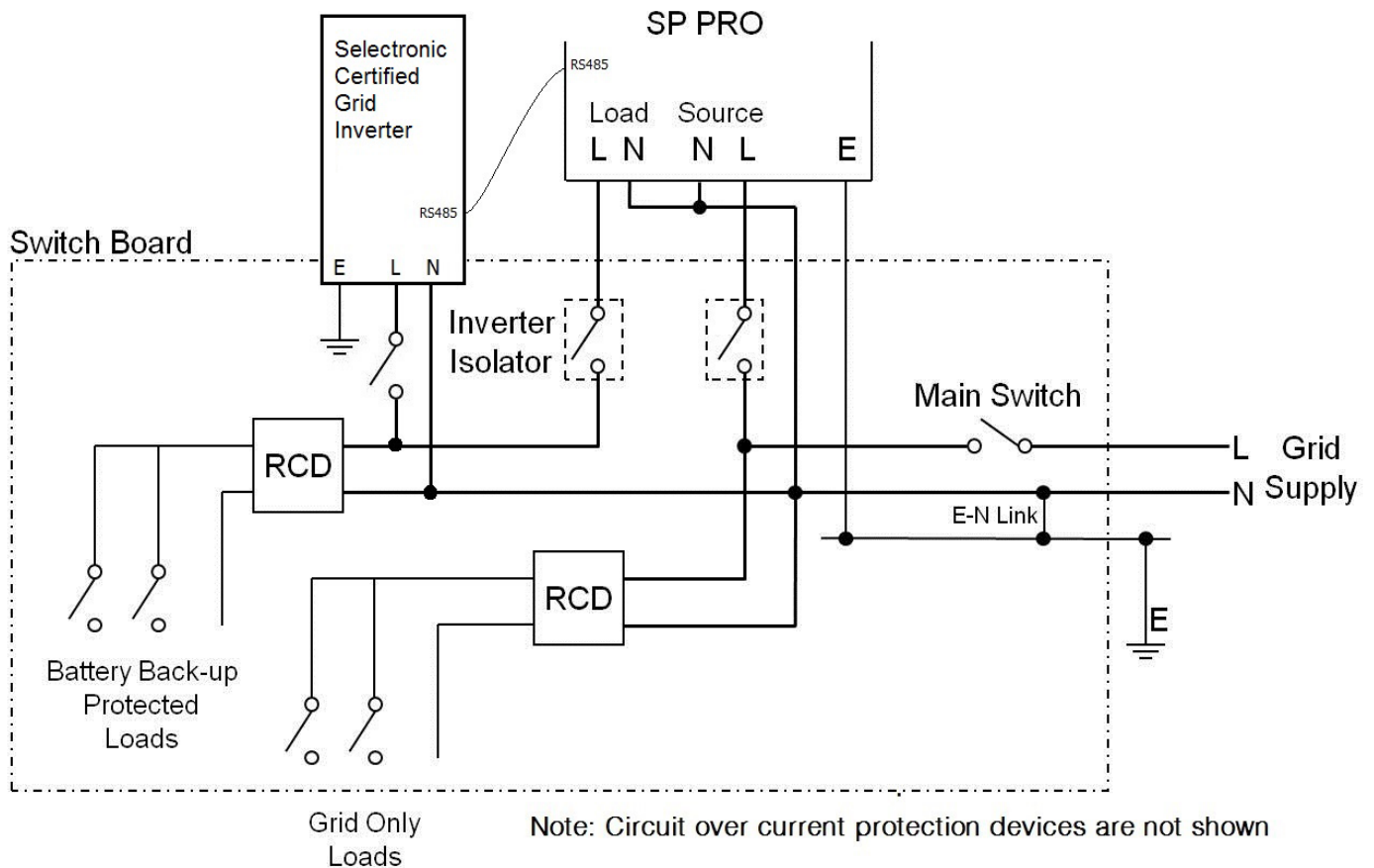

Diagram given as a reference only. Please ensure all wiring complies with relevant safety standards.



Backup Generator (Advanced Feature) Control Wiring

When a backup generator is installed, control wiring should be fed up through the appropriate gland and terminated to the SP PRO Expansion card. The minimum required is one pair of wires for a generator run signal which must be wired to one of the four relay outputs. "CAT5" type cabling or any multi conductor multi strand cable is suitable for all control wiring. The Expansion Card can be plugged in and out of the SP PRO for ease of wiring.

Serial Port Connection

The communication cable can be attached to either the USB or DB9 connections on the lower panel.



Only one device may be connected at any one time to either the USB or DB9. Unused device must be unplugged from its connector.

Battery power must be connected to be able to communicate with the SP PRO.

Gland Plate Fit out



To maintain the IP rating and safety approval of the SP PRO, all gland plate holes must be completely filled and all gland plates fitted correctly. Any gaps including empty gland holes are entry points for vermin and could effect thermal performance.

Gland plates supplied with the SP PRO have "knock outs" for ease of installation. Please do not "knock out" any unused gland holes and ensure all used holes have gland nuts (supplied) fitted.

Initial Start up Procedure

Before turning on the SP PRO:

- Check all connections, paying particular attention to correct polarity. Give each cable a firm tug to ensure they are securely fitted.
- When satisfied everything is well, attach the terminal cover plate and insert and secure the expansion card.
- For SPMC1201, SPLC1200 and SPLC1202 models - Protective cover **MUST** be installed on Expansion card.
- Close the battery sense / pre charge circuit breaker/fuses and wait until all indicators are lit and stable.
- Close Main battery circuit breaker/fuses.
- Press ON button (long press > 1 second) once. The AC Load indicator will be steady blue.
- Start using the SP PRO by switching on external AC circuit breakers.



For SPMC1201, SPLC1200 and SPLC1202 models - Check protective cover is installed on Expansion card.

- Replace cover and secure with two screws from below.

Labelling

Regulations mandate the application of warning and control labels to the various circuit breakers, isolators and switch boards in the installation.

The SP PRO will continue to provide power to the load upon interruption of mains supply. Warning signs must indicate which circuits or switchboards operate in this manner.



For examples of labelling that contain Start up and shutdown procedures please refer to the Appendix in the MyGrid installation Note *IN0027_xx 005048 myGrid Installation Notes_*
Found at <http://www.selectronic.com.au>



Installation-System Configuration



Chapter Four

This section details the extra information needed to install and configure standard system configurations. It is imperative that the installation details in the previous section have been followed before proceeding with the relevant installation instructions in this section.



Managed AC Coupled Preparation

For full installation details see document “IN0018_xx SP PRO KACO Managed AC Coupling Installation Notes”, “IN0036_xx 005150 SP PRO ABB Managed AC Coupling Installation Notes” or “IN0042_xx 005230 SP PRO Fronius Managed AC Coupling Installation Notes”. Also see the SP LINK “Site Configuration Wizard”, all available from the enclosed USB stick or the Selectronic Web site: www.selectronic.com.au

The SP PRO Managed AC Coupling provides a method of linking any of the Selectronic Certified grid tie inverters to the SP PRO via the AC Load supply so that regardless of whether the grid or a generator is connected, the SP PRO can manage and control the Selectronic Certified grid tie inverters.

Each SP PRO can manage a maximum of five Selectronic Certified grid tie inverters by commanding each to output the right amount of power that is needed to simultaneously supply the load, export any excess and maintain the battery bank at any particular point in time. This is done via a communications link which also serves to retrieve all the operational data for display and logging by the SP PRO.

Communications between SP PRO and Selectronic Certified inverters

The RS485 Communications links between the SP PRO and Selectronic Certified inverters can be either wired link (using CAT 5 cable) or a wireless link (Using the Optional Selectronic wireless RS485 link, stock code 005075, ABB grid inverters exempted). See diagram below for basic communications wiring



RS485 wired communications links between SP PRO and Selectronic Certified inverters

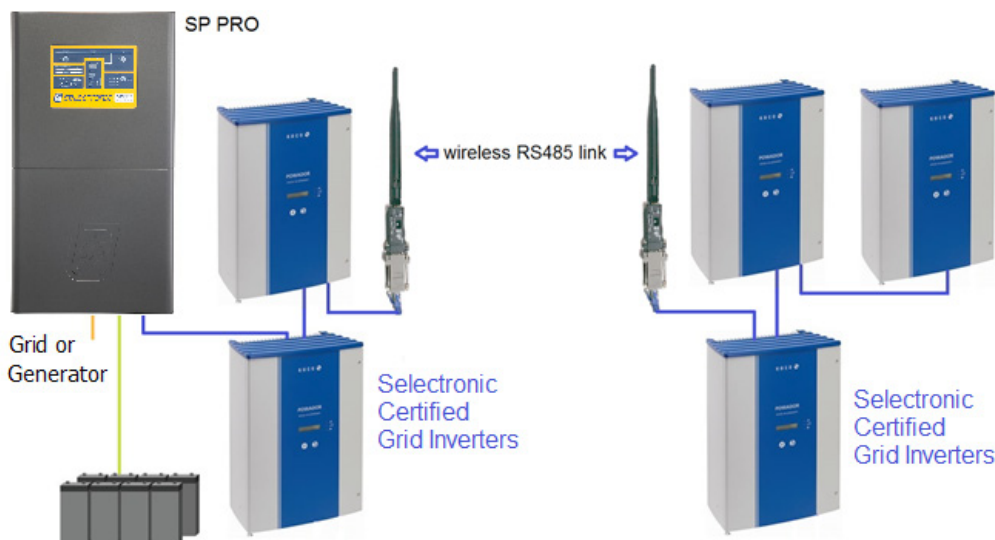

RS485 wired AND wireless communications links between SP PRO and Selectronic Certified inverters



Line diagram for single phase managed AC coupling

The below diagrams detail the AC wiring requirements for Managed AC coupled systems.

Please note that when a Solar Hybrid, Managed AC coupled system is installed with an existing grid connected PV system that has another brand of grid inverter (generic grid inverter) then the generic inverter is connected on the grid side of the system (See diagram below). If there is no existing grid inverter then ignore the grey wiring on the diagram below.

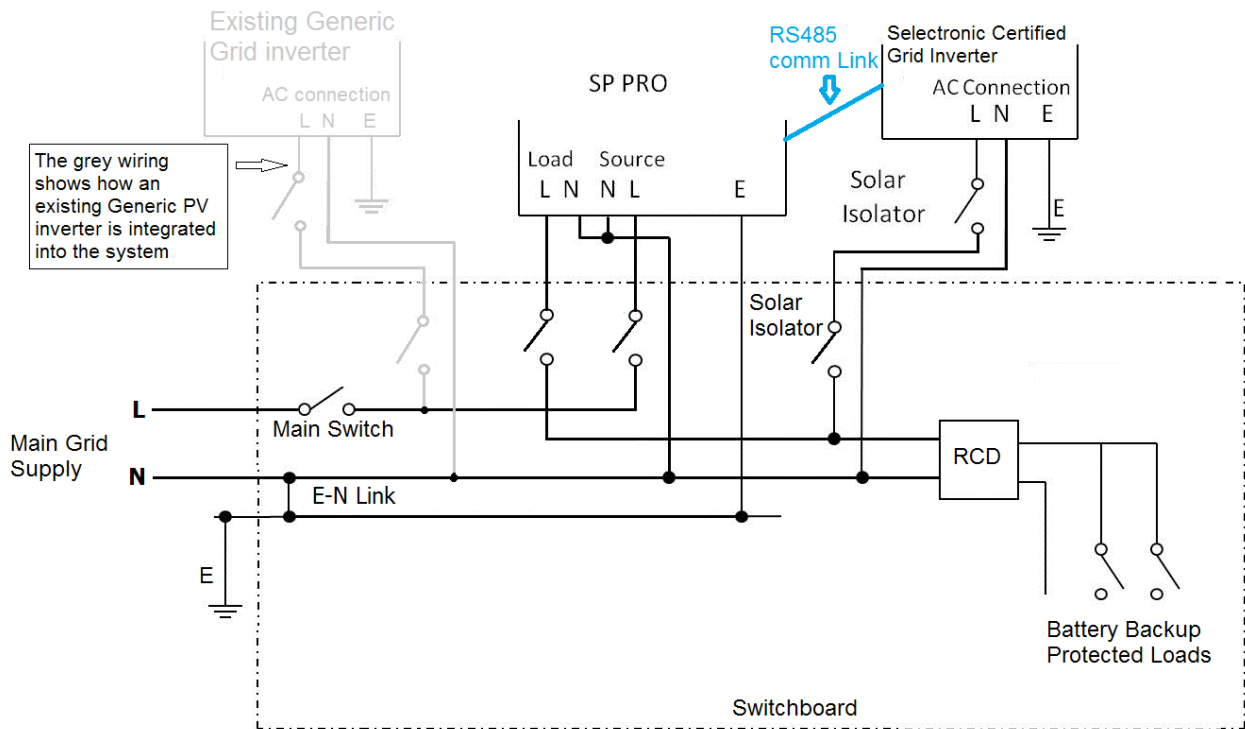

Line diagram for Managed AC coupling - Solar Hybrid (Grid Connected) System

Diagram given as a reference only. Please ensure all wiring complies with relevant safety standards.

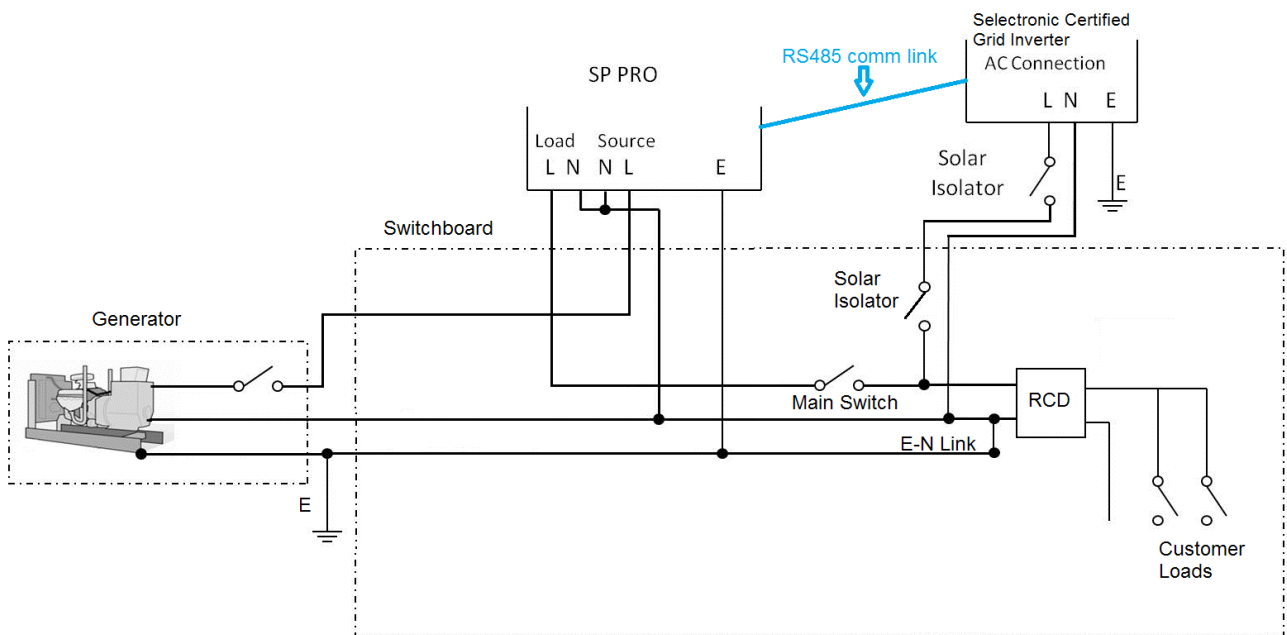

Line diagram for Managed AC coupling - Off Grid System

Diagram given as a reference only. Please ensure all wiring complies with relevant safety standards.



Minimum Battery capacity for Managed AC coupling

The following table gives the maximum allowable output power of all the Selectronic Certified grid inverters and the minimum battery size for Single Phase, Managed AC Coupled systems.

If a three phase system is installed then all the values below are multiplied by a factor of three.

If a two phase system (or split phase such as installed on a SWER line) is installed then all the values below are multiplied by a factor of two

NOTE: Battery capacity is at the C10 discharge rate.

SP PRO Model Family	¹ Maximum AC Output power of all Selectronic Certified Grid Inverters for off grid systems.	² Maximum AC Output power of all Selectronic Certified Grid Inverters for Solar hybrid systems	³ Minimum Battery Capacity, Lead Acid (C10)	⁴ Minimum Battery Capacity, LiFePO
SPMC240	6 kW	15kW	180 Ah	60 Ah (1.5kWh)
SPMC241	9 kW	15kW	180 Ah	60 Ah (1.5kWh)
SPMC481	10 kW	15kW	180 Ah	60 Ah (3.0kWh)
SPMC482	15 kW	15kW	180 Ah	60 Ah (3.0kWh)
SPMC1201	15 kW	15kW	100 Ah	30 Ah (3.8kWh)
SPLC1200	30 kW	30kW	250 Ah	80 Ah (10kWh)
SPLC1202	40 kW	30kW	250 Ah	80 Ah (10kWh)

The table above shows the following:

- 1, 2 The maximum combined AC output of all the Selectronic Certified inverters in the system for a particular SP PRO model.
2. This value is increased to 240kW when an external AC contactor is installed in the system.
3. The minimum Lead Acid battery capacity. at the C10 rate.
4. Based on Lithium Iron phosphate batteries with a maximum allowable charge rate of C2 or greater. Also applicable to other lithium technologies with a maximum allowable charge rate or C2 or greater

Note: Use the Site configuration Wizard in SP LINK to determine the ideal match between battery size and the output of the Selectronic Certified grid inverters.



Generic AC Coupled Preparation

For full installation details see document “IN0034_xx SP PRO Generic AC Coupling installation notes” and SP LINK “Site Configuration Wizard”. available from the enclosed USB stick or the Selectronic Web site: www.selectronic.com.au

To successfully install a SP PRO generic system, there are particular system requirements that need to be met. (See “IN0034_xx SP PRO Generic AC Coupling installation notes” for more detail)

- Combined maximum AC output of all the connected generic inverters must not exceed the continuous SP PRO output power rating.
- Battery bank must be sized to suit the SP PRO model and the combined maximum AC Output power of the generic inverters.
- SP PRO generic AC coupling is only suitable for grid connected systems.
- SP PRO generic AC coupling cannot control any grid export limits.
- The Grid Disconnect function in the Solar Hybrid Control should not be used.

The above diagram outlines the AC wiring for a SP PRO Generic AC coupled system

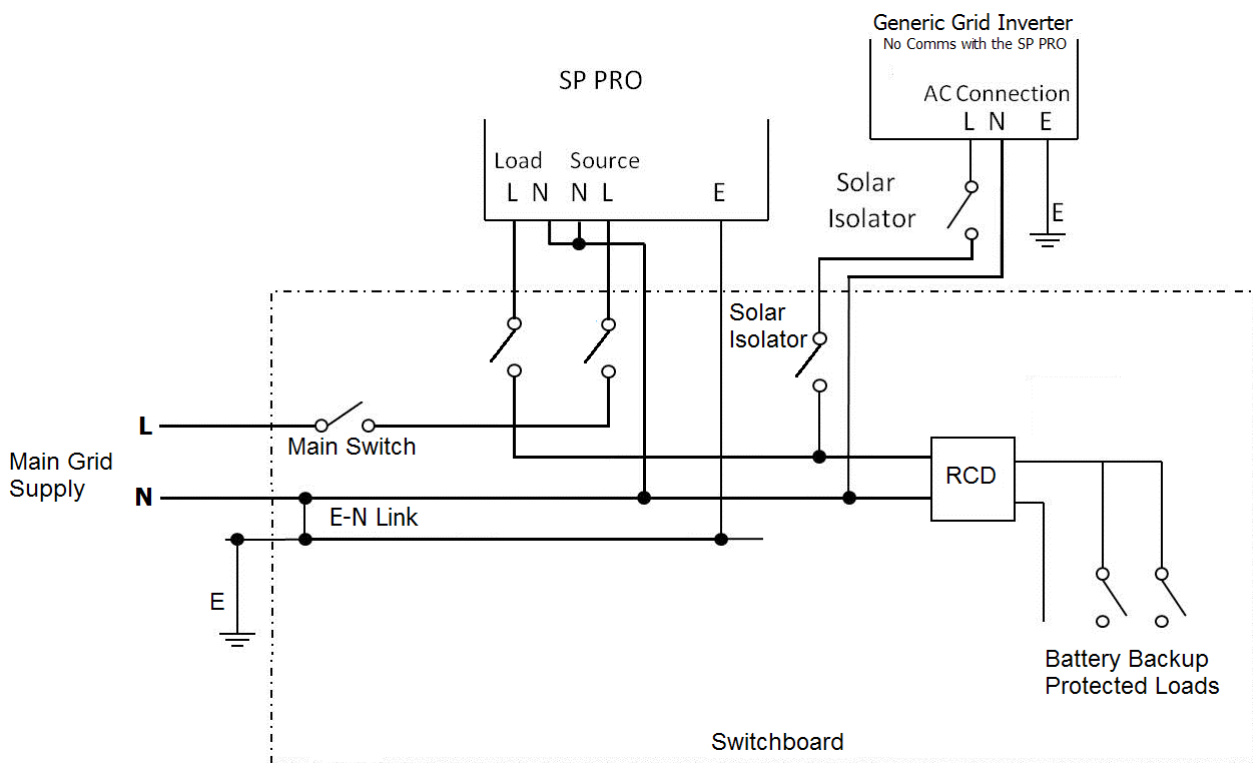

Line diagram for Generic AC coupling - Solar Hybrid System

Diagram given as a reference only. Please ensure all wiring complies with relevant safety standards.



Three Phase Preparation

Installing a three phase system using three SP PRO inverters requires the following optional Kit:
Stock code: 004775 Description: Gx Multi-Phase Pack series II - Available from a Selectronic Distributor.

For detailed information on preparing for a Three phase installation please refer to the document “IN0016_xx SP PRO Three Phase Installation” found in the Gx Multi-Phase Pack series II, on the USB stick supplied with this inverter or on the support page of the Selectronic web found site at www.selectronic.com.au.

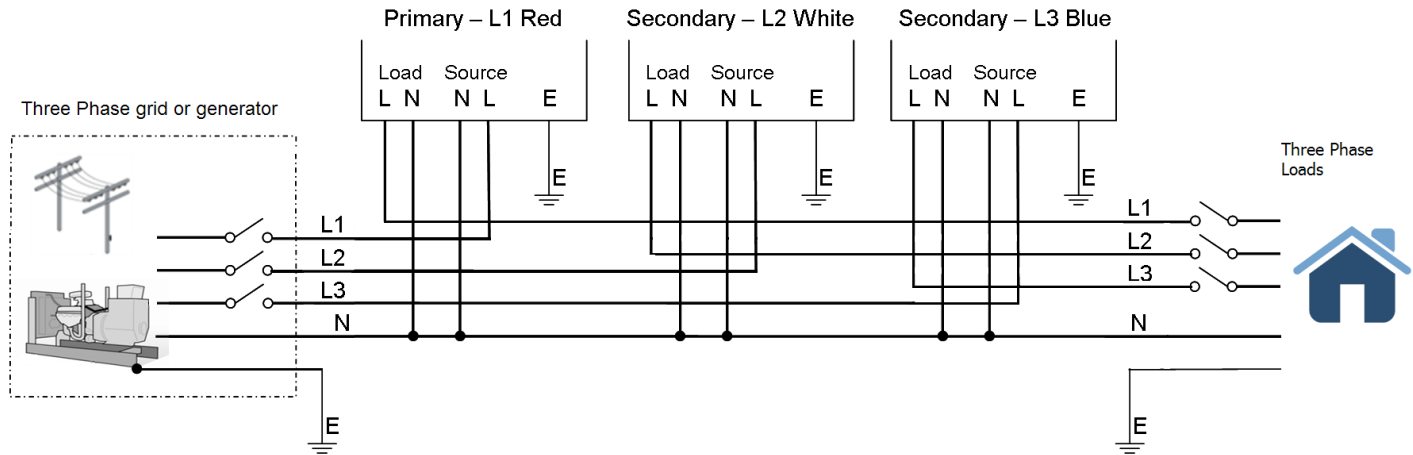

Diagram given as a reference only. Please ensure all wiring complies with relevant safety standards

Split Phase Preparation

A split phase system is suitable for connection to a 480V split phase grid supply that is commonly found on Single Wire Earth Return (SWER) line feeds.

Installing a split phase system using two SP PRO inverters requires the following optional Kit:
Stock code: 004775 Description: Gx Multi-Phase Pack series II - Available from a Selectronic Distributor.

For detailed information on preparing for a Split phase installation please refer to the document “IN0033_xx SP PRO Split Phase Installation” found in the Gx Multi-Phase Pack series II, on the USB stick supplied with this inverter or on the support page of the Selectronic web found site at www.selectronic.com.au.

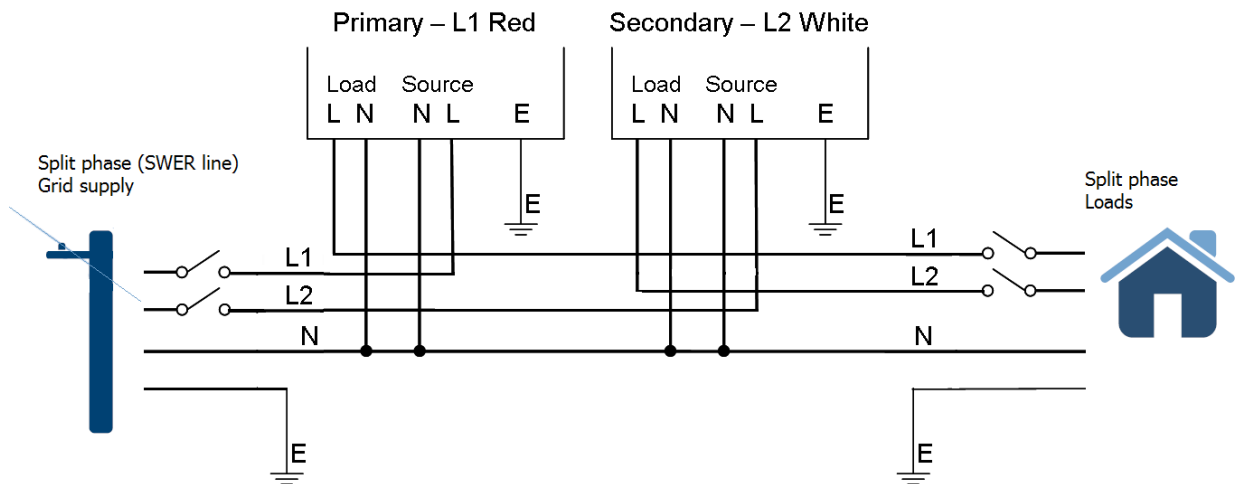

Diagram given as a reference only. Please ensure all wiring complies with relevant safety standards.



DC couple Charge Controller Preparation

Before a DC coupled (charge current fed directly to the battery bank) renewable energy charge controller is installed and integrated into the system the following requirements must be adhered to:

- All DC coupled charge sources must be fed to the battery bank via an optional current shunt.
- All DC coupled charge controllers must have either an output that is activated when the charge controller reaches float OR an input that triggers the charge controller to a float charge state.

Failure to install a current shunt or charge stage linking will reduce the performance and result in non -optimal operation of the system.

For more detail on installing and integrating a DC charge controller refer to the relevant document in the table below All documents found on the USB stick supplied with this inverter or on the support page of the Selectronic web found site at www.selectronic.com.au

Document Number	Document Name	Applicable charge Controller
TN0045	SP PRO Shunt Installation	All Charge controllers
AN0002	SP PRO Renewable Regulator Integration	All CHarge controllers
TN0029	SP PRO PL Regulator Integration	Plasmatronics PL regulator
TN0031	SP PRO DINGO Regulator On Grid Export Integration	DINGO regulator
TN0030	SP PRO DINGO Regulator Float Integration	DINGO regulator
TN0033	SP PRO Outback Flexmax 60-80 Regulator Float Integration	Outback Flexmax 60/80 regulator

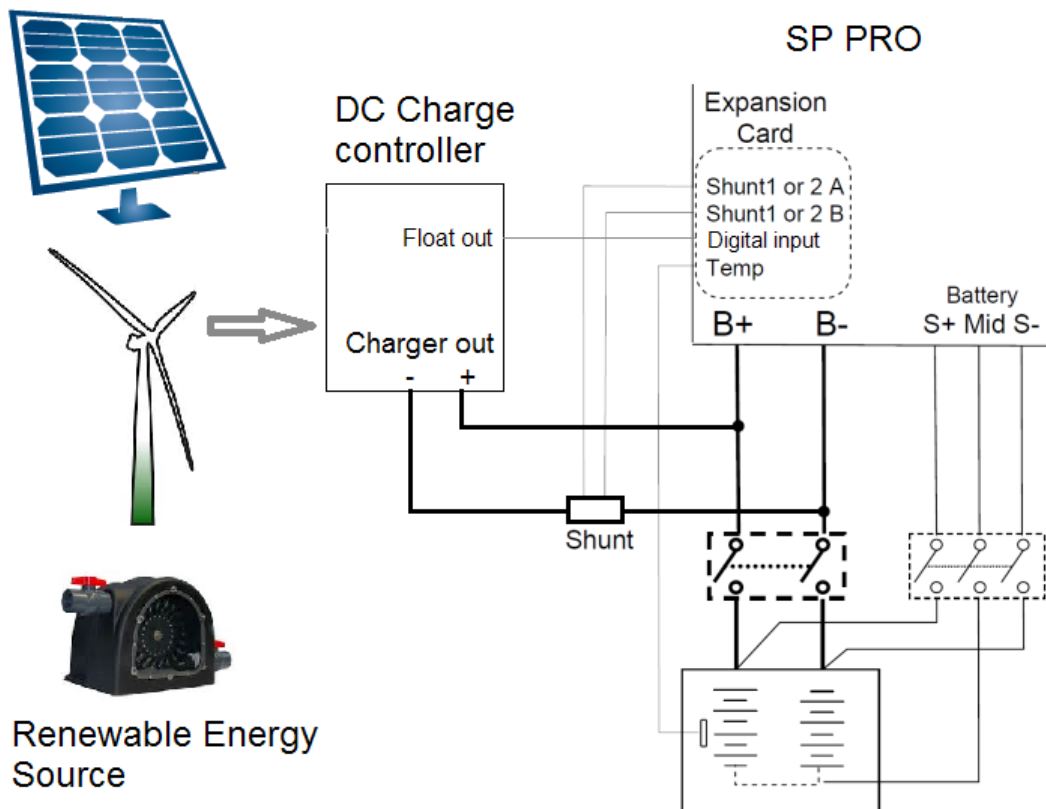

Line diagram for DC Coupled Charge Controller Integration

Diagram given as a reference only. Please ensure all wiring complies with relevant safety standards.





Installation-Ancillary Components

Chapter Five



Inputs and Output

All SP PRO models come standard with four digital inputs, three digital outputs and four relay outputs. Additionally the 24V and 48 V models include two analogue inputs.

Each input and output is fully programmable and can be used to provide advanced functionality.

The ratings of the digital inputs and outputs are tabulated below

Digital Inputs (x4)	Maximum input voltage 60 V DC Active when input > +10 VDC, Inactive when input < +3 VDC
Analogue Inputs (x2, 24 and 48V models only)	Input voltage range 0-60 VDC - These inputs are logged in the Data Download.
Relay Outputs (x4) N/C and N/O dry contacts	Maximum control voltage 60 VDC Maximum control current 500 mA DC (Limited by internal current protection)
Digital outputs (x3)	Maximum control voltage 60 VDC Maximum control current 5 mADC

Analogue Inputs

The 24V and 48V SP PRO inverters have 2 analogue inputs that are logged and that can be used to control a digital or relay output based on set input voltages.

Digital Inputs

Each SP PRO has an internal 12V 1A supply on the communications card, which is suitable for controlling the SP PRO digital inputs. The schematic below demonstrate the connections for controlling a digital input from dry contacts on an external device.

The table below lists all of the functions available for digital inputs on the SP PRO inverter. All the settings are in the "Inputs / Outputs" tab under "Configuration settings". (for more information see the SP LINK manual.)

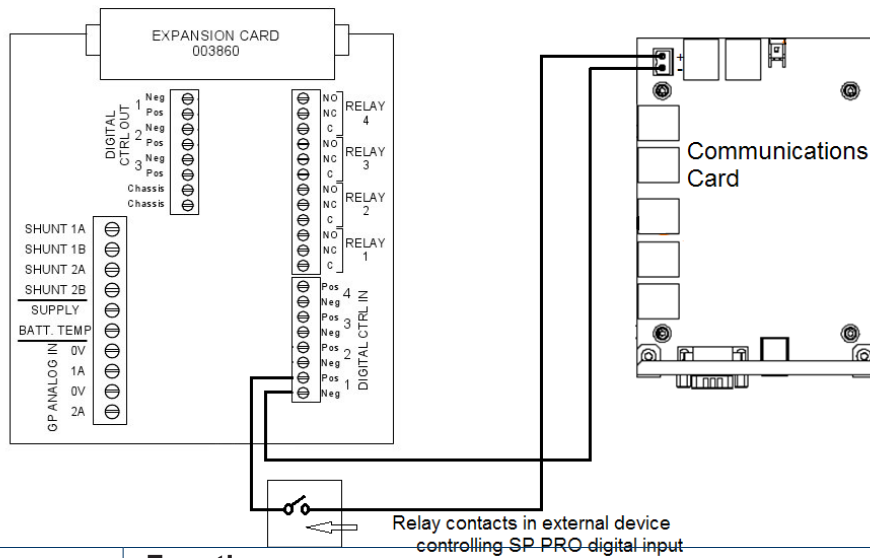

Setting name	Function
Low Batt Shutdown Override Input	Forces the inverter to run after a low voltage shutdown. Used in an emergency to keep power running.
Normal/Alternate AC Input Power Selector	Selects a second AC Source with a different capacity to the primary AC Source.
Inhibit Export Input	Prevents the SP PRO from exporting power to the AC source. For example when the grid has failed and a diesel generator is connected into the system.
Shutdown Input	Turns off the inverter section of the SP PRO (Idle mode) to prevent charging or discharging of the battery system by the SP PRO. In a grid connected system, If the grid is present then grid is passed through to the load to maintain power. In an off grid system with an auto start generator, the generator is started to maintain power to the system.
Digital Control Input	Controls a Relay output or digital output in the SP PRO
Generator Remote Start Input	Remote control to start an Auto start generator that is connected to the SP PRO
Generator Available Input	When inactive, prevents the SP PRO from starting an Auto start generator that is connected to the SP PRO
Generator Low Fuel input	When active will initiate a low fuel alarm
Generator No Fuel input	When active will either stop the generator or prevent it from starting
Generator Fault input	When active will either stop the generator or prevent it from starting
Initial stage input	Causes the Battery charger in the SP PRO to drop to the Initial stage
Bulk stage input	Causes the Battery charger in the SP PRO to drop to the Bulk stage
Absorb stage input	Causes the Battery charger in the SP PRO to drop to the Absorb stage
Float stage input	Causes the Battery charger in the SP PRO to drop to the Float stage
Equalise stage input	Causes the Battery charger in the SP PRO to drop to the Equalise stage
Grid Available Input	In a single phase system - Used with the Grid Fail / Generator Backup option to tell the SP PRO the grid is back. In a three phase system - Used to tell L1 (primary SP PRO) that the L2 and L3 phases are in tolerances and system can be connected to the AC input
Activation Input (Solar Hybrid priority activation)	Each of the Solar Hybrid priorities can be configured to be activated by either time or via one of the digital inputs. See SP LINK manual for more details



Digital and Relay Outputs

Each relay output has a normally open and normally closed set of dry contacts. These can be used directly to control devices requiring on/off type control. Each relay output is isolated from the next.

If a 12V control signal is required then the relay output can be used to switch the internal 12V 1A supply on the communications card. The schematics below demonstrate some connection options for controlling an external device.

Each Digital output is an “open collector” switch and is polarity sensitive. Because this is an electronic switch it is suitable for fast and often switching functions

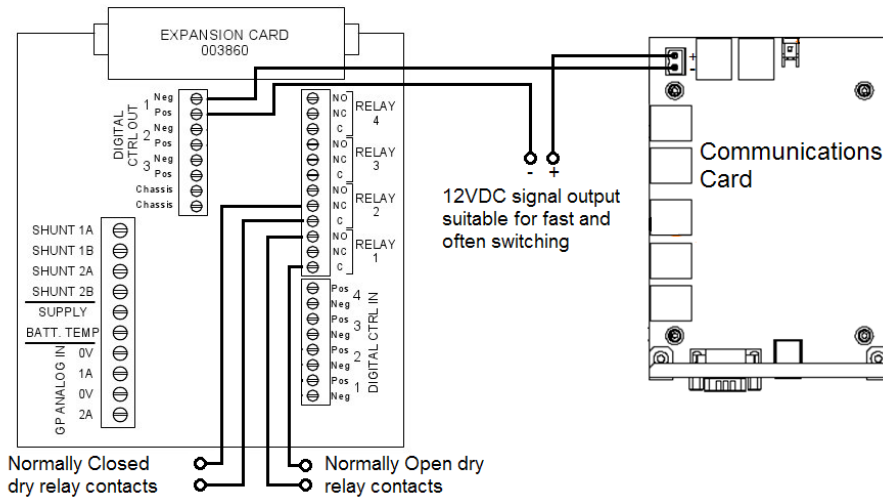

The table below lists all of the functions available for digital and relay outputs on the SP PRO inverter. All the settings are in the “Inputs / Outputs” tab under “Configuration settings”. (for more information see the SP LINK manual.)

Setting name	Function
Analogue Control Output	Output is controlled by voltage levels on an analogue input.
Generator Run output	Provides a constant output to start an auto start generator.
Generator Start output	Provides a pulse output to start an auto start generator.
Alarm Output	Output becomes active when the SP PRO is in alarm condition.
AC Load Energy Output	Output becomes active when a set Daily Load kWh is exceeded
AC Load Power Output	Output becomes active when a set Load kW is exceeded.
External Regulator Bypass Output	Used to control an external relay that will bypass the DC charge controller when system connected to the grid
External Regulator Control Output	Provides a PWM signal to control an external solar regulator.
AC Coupled Inverter Output	Controls a Solid State relay that turns off a generic AC coupled inverter when the grid has failed and the battery voltage reaches its charge target.
External AC Contactor Control Output	Becomes active when the AC Source contactor opens. Used to drive an External AC source contactor or as an AC source failure output.
AC Source in Tolerance Output	Output becomes active when the AC source voltage and frequency are in tolerance.
High Battery Alert Output	Becomes active when the battery voltage reaches the Hi Battery Alert set point.
Battery SoC Output	Output is controlled by battery SoC set points.
Battery Voltage Output	Output is controlled by battery voltage set points
Initial Stage Output	Is active when the SP PRO charger is in the Initial stage.
Bulk Stage Output	Is active when the SP PRO charger is in the Bulk stage.
Absorb Stage Output	Is active when the SP PRO charger is in the Absorb stage.
Float Stage Output	Is active when the SP PRO charger is in the Float stage.
Equalise Stage Output	Is active when the SP PRO charger is in the Equalise stage.
Timed Assert Output	Driven by four time-of-day and day-of-week schedules
Backup Select Output	Used to control the contactor in the Grid Fail / Generator Backup Option,



External AC Source contactor

When the maximum transfer current is greater than the rating of the SP PRO (63A or 63A per phase for SPMC models and 125A or 125A per phase for the SPLC models) an external AC source contactor and AC source current transformer (CT) may be fitted (CT secondary = 5A and burden >2.4VA). With an external contactor, transfer currents of up to 1,000A are possible (1,000A per phase in a three phase system).

The line diagrams below are for the external contactor in both a single phase configuration and three phase configuration.

For more detailed information please see “TN0057_xx SP PRO External AC Source Contactor Option.doc” available on the USB stick packed with the SP PROGO or from the selectronic web site:
www.selectronic.com.au.

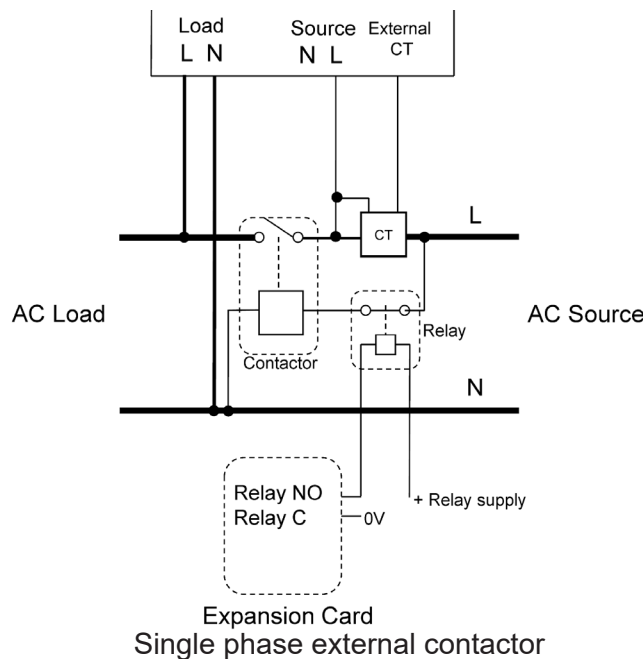

Diagram given as a reference only. Please ensure all wiring complies with relevant safety standards.

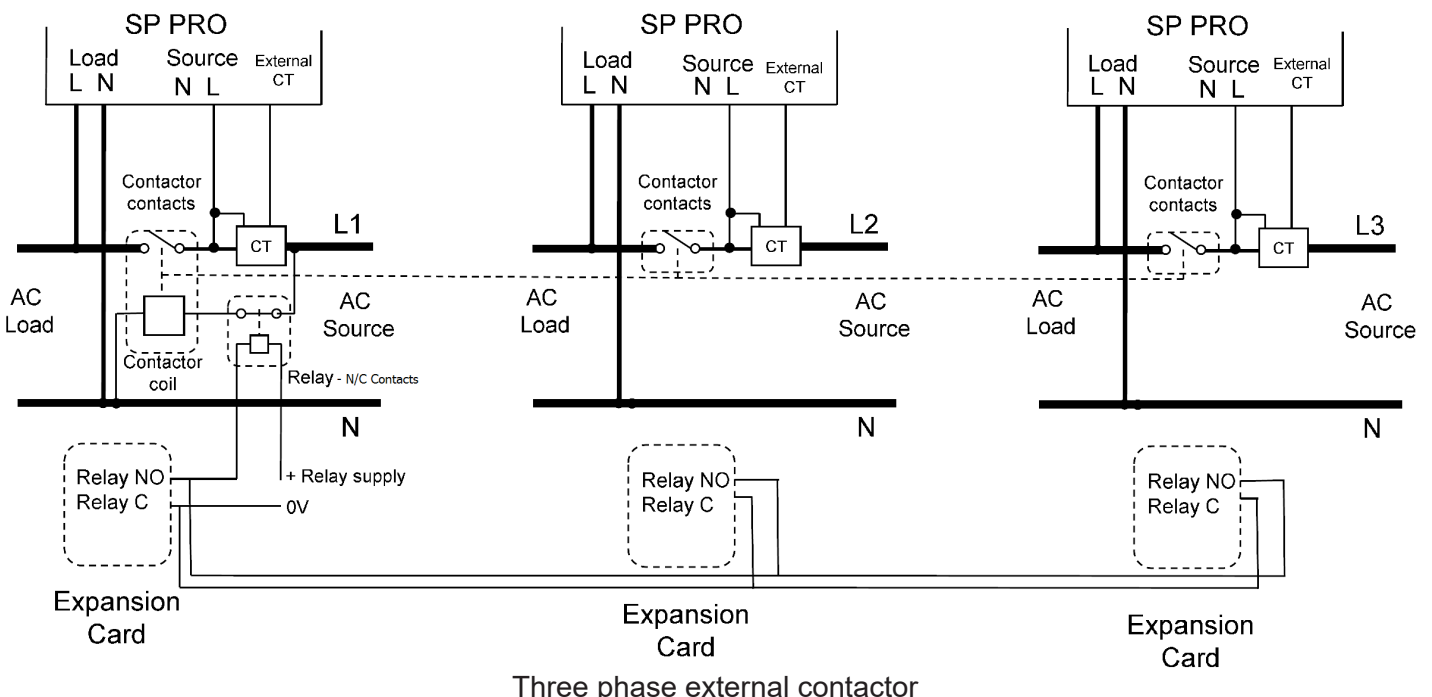

Diagram given as a reference only. Please ensure all wiring complies with relevant safety standards.



Adding a backup Generator (Solar Hybrid)

With the Optional Grid Fail / Generator Backup kit (see table below) an auto start backup generator can be added to a SPMC model of the SP PRO in a single phase Solar Hybrid (grid connected) system.

When the grid fails the customer’s load power will be supplied from the battery bank until either the load becomes too large for the system or the battery reaches a set SoC. At that point the generator will start to run the loads and charge the battery bank. The generator will continue to run until either the battery bank has recharged or grid power has been restored.

For more detailed information please see “IN0020_xx 004799 SP Grid - Gen Backup Installation Notes” supplied with the Grid Fail / Generator Backup kit, available on the USB stick packed with the SP PRO or from the selectronic web site:
www.selectronic.com.au.

SP PRO Model		Grid fail – Generator backup kit	
SPMC 240-AU	004723	SPMCA-GFGB-24V	004743
SPMC 241-AU	004724	SPMCA-GFGB-24V	004743
SPMC 481-AU	004725	SPMCA-GFGB-48V	004744
SPMC 482-AU	004726	SPMCA-GFGB-48V	004744
SPMC 1201-AU	004722	SPMCA-GFGB-120V	004745

NOTE: A Grid fail/Generator backup kit is NOT required when adding a generator to an Off Grid system.

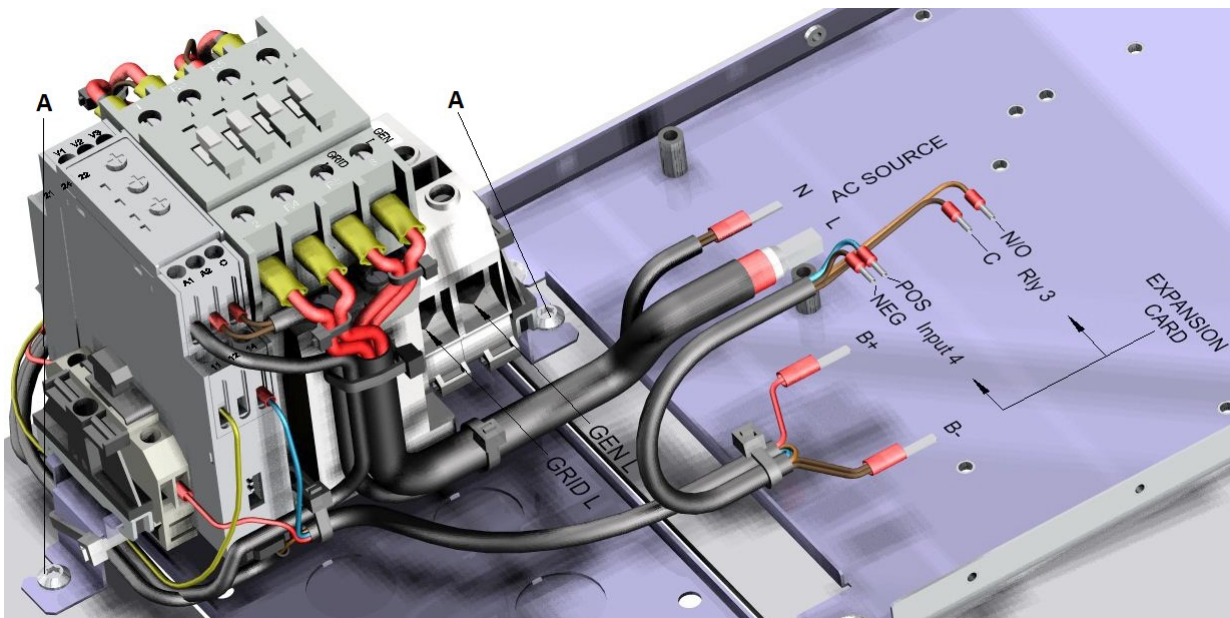



Adding a Generator (Off Grid)

The SP PRO may be configured to automatically control a generator in an Off Grid power system. The generator may be automatically started by the SP PRO as required to supply the load and charge the battery bank or be configured to allow manual control of the generator by the user. Generally automatic control of the generator is recommended for daily operation.

The line diagram below shows the connections AC connections for the generator. The generator control link can be set up as a 2 wire or 3 wire configuration. For more information on the control wiring please see document “TN0025_xx SP PRO Generator Controller Wiring Guide” Found in the USB supplied or the Selectronic Web site.

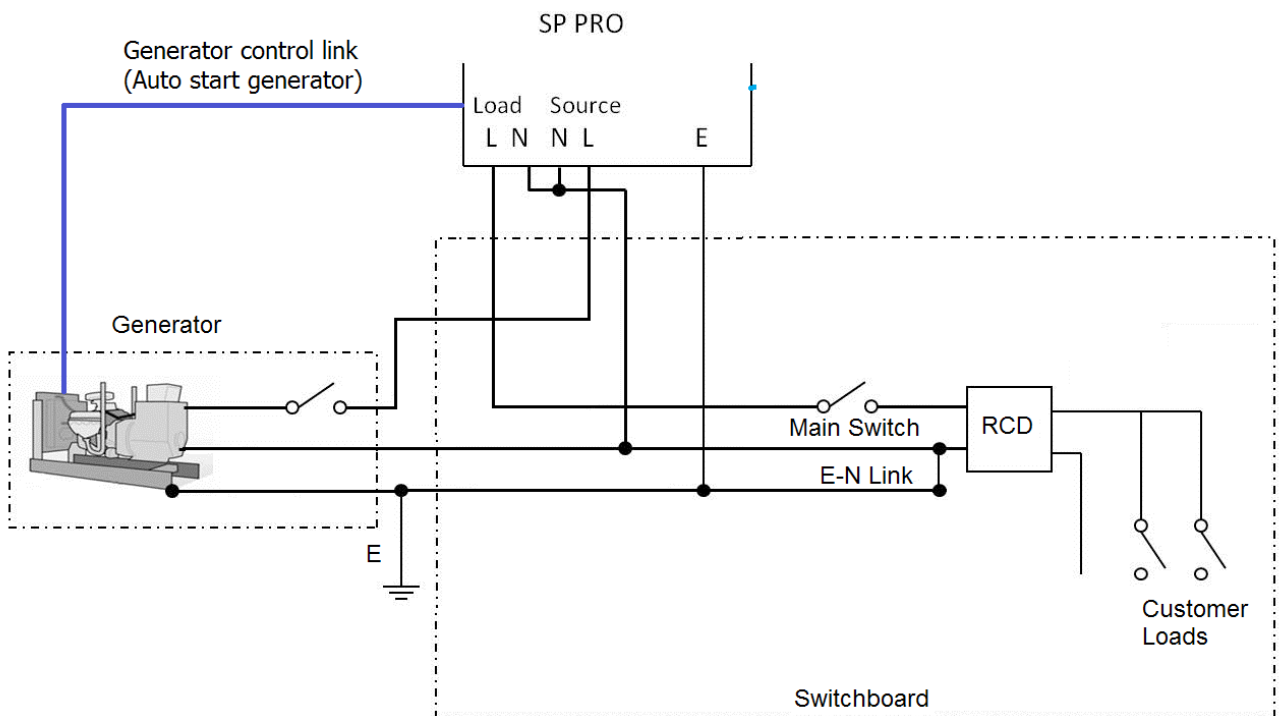

Line diagram for Selectronic Certified grid Managed AC coupling - Off Grid System

Diagram given as a reference only. Please ensure all wiring complies with relevant safety standards.



Installation- Communications

Chapter Six



Communications Overview

All SP PRO inverters have a number of standard communications interfaces and provision for a number of optional communications interfaces.

Below is a summary of standard communications ports.

Port name (connector)	Port Function
Sync 1, 2 (RJ45)	Used for inter inverter communications in a 3 phase or Split phase configuration.
RS485 Port 2 (RJ45)	Used to communicate with Selectronic Certified grid inverters in a managed AC coupled system.
RS232 Port 2 (RJ45)	Provides RS232 communications with SP LINK Cannot be used when RS485 Port 2 is used.
RS232 Port 1 (RJ45)	Provides RS232 communications with SP LINK Cannot be used when USB port or DB9 port is used.
RS232 Port 1 (DB9)	Provides RS232 communications with SP LINK Cannot be used when USB port or RJ45 port 1 is used
USB Port 1 (USB type B)	Provides USB communications with SP LINK Cannot be used when RS232 port 1 is used

Below is a summary of available optional communication interfaces

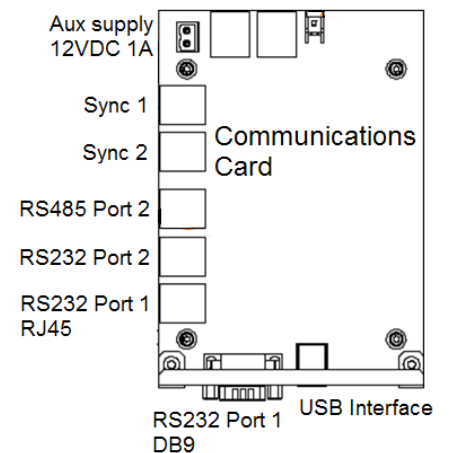

Option name	Function
Wireless SP PRO to SP LINK (Stock code 004859)	Wirelessly connect the SP PRO to the USB port of the PC running SP LINK
Ethernet Adaptor - LAN (Stock code 005081)	Connect the SP PRO to a Local Area Network (LAN). Allows any PC connected to the LAN to communicate via SP LINK.
Ethernet Adaptor - Internet (Stock code 005081)	Using the same Ethernet adaptor the SP PRO can be connected to the Internet. This requires configuration of the router and advanced knowledge of networks.
Wireless RS485 (Stock code 005075)	Provides wireless communications between SP PRO and Selectronic Certified grid inverters in a managed AC coupled system

USB communications

All SP PRO inverters come standard with a USB “B” interface to communicate with a PC running SP LINK.

To use the USB communications interface simple install and run SP LINK on a PC, turn on the SP PRO inverter and connect it to the PC via the supplied USB cable.

The details of the connected inverter will appear in SP LINK under the “Connection settings” tab. Click the “Connect” button and SP LINK will be connect to and will communicate with the SP PRO.



NOTE: When the USB port is being used, both the RS232 Port 1 connectors (the RJ45 connector inside the SP PRO and the DB9 connector at the base of the SP PRO adjacent to the USB port) are unavailable and all communications devices connected to these ports must be removed.

SP PRO Details **Connection Settings** Components

* Connection Type: USB Model:SPMC482 Serial:155008

* Login Password:

Modem Phone Number:

Modem Initialisation:

Hostname or IP Address: Port:

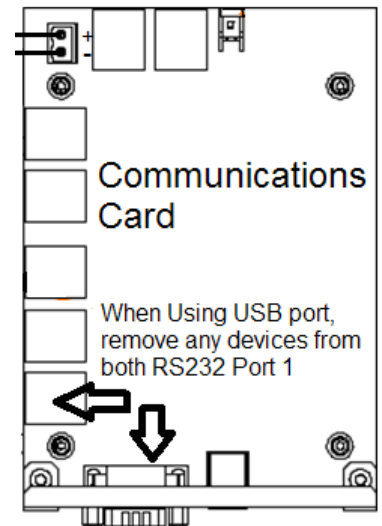

RS232 serial communications

To enable communications with legacy interfaces the SP PRO has two RS232 ports.

RS232 Port 1 is provided on either a RJ45 connector or DB9 connector. Only one of these options may be used at any one time and neither can be used when the USB option is connected.

RS232 Port 2 is only provided on a RJ45 connected. This port can only be used when the RS485 Port 2 is not in use.



The RS232 ports are wired as DTE with their pinouts listed in the table below.

Pin	Signal RS232 Port 1 RJ45	Signal RS232 Port 1 DB9	Signal RS232 Port 2 RJ45
1	+12V 1A supply	N/C	+12V 1A supply
2	N/C	Receive (Input) Data	Data Terminal Ready
3	Transmit (Output) Data	Transmit (Output) Data	Transmit (Output) Data
4	Signal Ground	N/C	Signal Ground
5	Signal Ground	Signal Ground	Signal Ground
6	Receive (Input) Data	N/C	Receive (Input) Data
7	N/C	N/C	Data Carrier Detect
8	N/C	N/C	N/C
9	-	+12V 1A supply	-

Wireless SP PRO to SP LINK

By simply installing this option (Stock code 005081) the SP PRO can be easily connected to a remote PC running SP LINK.

For more detailed information please see “IN0023_xx SP PRO to SP LINK Wireless Link Installation Notes”, available on the USB stick packed with the SP PRO or from the selectronic web site:
www.selectronic.com.au.



Device plugged into SP PRO



Device plugged into USB on Computer



SP PRO Ethernet Adaptor

Connecting to a LAN

Using the optional Ethernet adaptor (Stock code 005081), the SP PRO can be connected into a Local Area Network (LAN). Any PC running SP LINK that is connected to the same LAN can have access to the SP PRO.

For more detailed information please see “IN0031_xx SP PRO Ethernet adaptor for LAN connection”, available on the USB stick packed with the SP PRO or from the selectronic web site:



Connecting to the Internet

Once the Ethernet Adaptor is connected to the LAN and access is established, the SP PRO can then be given remote access to any PC that is connected to the Internet. The configuring of the router to achieve remote access can be carried out by a person who is familiar with general router and gateway configuration plus operation of Domain Names Servers (DNS).

For more detailed information please see “TN0028_xx SP PRO Communications - Internet Connectivity”, available on the USB stick packed with the SP PRO or from the selectronic web site:

RS485 - Managed AC coupling link

The RS485 port is used for communicating with the Selectronic Certified grid inverters in a managed AC coupled system.

For more information on wired and wireless RS485 connections and options please see “Managed AC Coupled Preparation” on page 29



Installation-Configure with SP LINK



Chapter Seven

Overview

“SP LINK is the pathway to the real power of the SP PRO”

SP PRO is suitable for either Solar Hybrid (grid connected) or Off Grid (no grid power) power systems and is easily configured to suit any application.

Use the SP LINK Site Configuration Wizard in the Easy Start Guide to configure the SP PRO for most applications or access the many advanced parameters to configure the SP PRO for a more complex system.

SP LINK software is available from the supplied USB stick or download the latest version from the Selectronic Web site at: www.selectronic.com.au.

We strongly suggest that SP LINK is installed on your PC before going to the installation site.



This section of the SP PRO manual is an introduction to SP LINK. For detailed information on SP LINK, please consult the SP LINK manual found in the HELP menu within SP LINK or on the USB stick supplied with the SP PRO



Configuring The SP PRO For All System Configurations

By installing and running the latest version of SP LINK, all standard Systems Configurations can be quickly and easily created and programmed into the SP PRO.

Simply run the Site Configuration Wizard, enter in the system details and SP LINK will firstly validate the combination of system components then create a site file.

All that is left to do is add any custom functions to the Configuration Settings, save the Site file to your computer then connect to the SP PRO and send it the configuration (click “Configure SP PRO” button).

For more information select “View SP LINK manual” in the Help menu in SP LINK or right click most tabs, buttons or headings.

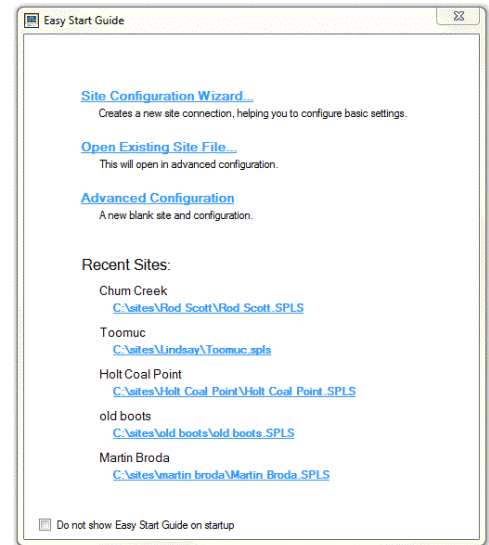



Installation- Commissioning

Chapter Eight



Introduction

Now that the system has been installed and the SP PRO has been configured, it is vital that the following commissioning processes be followed to verify correct installation of the system. Spending this time now will save time later.

It is important that all the details are filled out in the relevant commissioning sheets on the following page as this will assist in diagnosing any system now and in the future.

To ensure that you receive the highest level of support please ensure that the following commissioning documents are completed and available before contacting Selectronic Support.

Diagnostics during Commissioning

If the alarm buzzer sounds and one of the alarm LEDs is RED during the commissioning process please do the following to diagnose the system fault:

- Connect to the SP PRO via a PC that is running SP LINK
- Go to the Data View - Now tab and read the messages in the Attention Require box.
- Right click the Attention Required heading to view the SP LINK manual that lists all the messages, their meanings and required action.



Common System Checks

There are a number of standard checks that are common to all SP PRO based power systems. Please check off or record the value of all items in the following check list. For Single phase system just record the value for L1 (ignore L2 and L3).

Item to check	Result
Record Inverter model number and serial number	Model _____ Serial _____
Check the physical location of the SP PRO(s) in relation to all items listed in "Preparation" on page 14	
Check all main battery connections are correct and tight including: <ul style="list-style-type: none"> •Battery interconnects •Battery connections to battery •Connections to battery fuses or CBs •Connection to intermediate terminals •Connection to the SP PRO(s). Insulation is not clamped in terminal. 	
Check polarity of all main battery connections including: <ul style="list-style-type: none"> •At the battery bank •At the fuse or CB connections. Checked that they are not crossed. •At the SP PRO(s) Battery Terminals 	
Check precharge/battery sense wiring including <ul style="list-style-type: none"> •Connections to the battery bank •Connection to the SP PRO(s). Insulation is not clamped in terminal. 	
Check polarity of precharge/battery sense wiring including: <ul style="list-style-type: none"> •At the battery bank •At the fuse or CB connections. Checked that they are not crossed. •At the SP PRO(s) Battery Terminals. 	
With a multimeter check the voltage on the mid point terminal on the precharge/battery sense. This should be half the battery bank voltage.	
Check all other DC wiring in the system	
Check all AC wiring connected to the SP PRO(s) including the following: <ul style="list-style-type: none"> •The AC source terminals are wired to the grid or generator supply. •The AC load terminals are wired to the customer's loads •The AC outputs of the connected Selectronic Certified grid inverters are connected to the AC load terminals on the SP PRO(s). •All Neutral and Line connections are correct polarity. 	
Retighten all AC wiring terminals, N,L and E, and check there is no insulation in terminal, including connections to the SP PRO(s).	
Turn on the AC Source input to the SP PRO(s). DO NOT turn on the DC battery supply or the precharge/battery sense supply. Three blue LEDs will light up on each inverter. AC SOURCE, TRANSFER and AC LOAD.	
Turn off AC Source and check that AC load is turned off. Turn on precharge/battery sense breaker or fuses. After 10 seconds all the LEDs light up Red then Green before settling to normal display.	

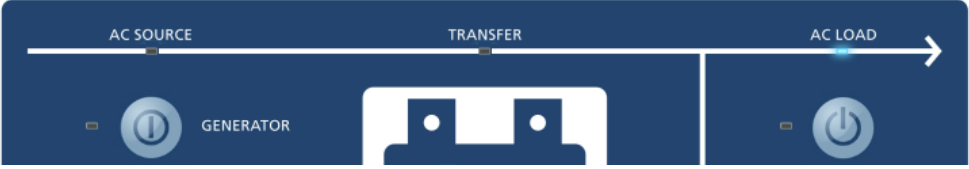

Item to check	Result																		
<p>Turn on Main DC Breaker or Fuses. Do a long press on the ON button (on L1 for multi-phase). The blue AC LOAD led will light on each SP PRO</p> 																			
<p>Run SP LINK on a PC and connect to SP PRO via the USB port.</p>																			
<p>Go to the Data View - Technical Data tab and read and record the following for each:</p> <ul style="list-style-type: none"> •Sense Voltage - should be equal to the DC Inverter Voltage reading. Both should be equal to the voltage at the battery terminals •DC Inverter Voltage •Midpoint Voltage (Where mid point is connected, otherwise ignore) - should be half the Sense Voltage. •Midpoint Error - should be < 5% unless battery bank needs to be equalised 	<table border="1"> <tr> <td>Sense Voltage</td> <td>L1</td> </tr> <tr> <td>52.2 V</td> <td>L2</td> </tr> <tr> <td>DC Inverter Voltage</td> <td>L3</td> </tr> <tr> <td>52.2 V</td> <td>L1</td> </tr> <tr> <td>Midpoint Voltage</td> <td>L2</td> </tr> <tr> <td>26.1 V</td> <td>L3</td> </tr> <tr> <td>Midpoint Error</td> <td>L1</td> </tr> <tr> <td>-0.02 %</td> <td>L2</td> </tr> <tr> <td></td> <td>L3</td> </tr> </table>	Sense Voltage	L1	52.2 V	L2	DC Inverter Voltage	L3	52.2 V	L1	Midpoint Voltage	L2	26.1 V	L3	Midpoint Error	L1	-0.02 %	L2		L3
Sense Voltage	L1																		
52.2 V	L2																		
DC Inverter Voltage	L3																		
52.2 V	L1																		
Midpoint Voltage	L2																		
26.1 V	L3																		
Midpoint Error	L1																		
-0.02 %	L2																		
	L3																		
<p>Put a load on the system that is about half the rating of the SP PRO(s) In the Data View - Now tab (L1) read and record the Battery Current.</p>																			
<p>Also read and record Battery Voltage</p>																			
<p>Back in the Data View - Technical Data tab read and record the Cable Loss (L1). Cable Loss should be less than 1% of load power for 24V system, 0.5% of load power for 48V and 120V systems</p>																			
<p>Drop the load to about half In the Data View - Now tab (L1) read and record the Battery Current. Also read and record Battery Voltage</p>																			
<p>Check the battery temperature sensor(s) is installed according to “Battery Wiring (DC) Preparation” on page 24</p>																			
<p>Back in the Data View - Technical Data tab read and record the Battery Temperature for each inverter. Check that this is correct and they are all the same.</p>	<p>L1 L2 L3</p>																		
<p>Activate all used digital inputs and check for > 10VDC but < 60VDC Deactivate all used digital inputs and check they are < 3VDC</p>																			
<p>Activate all used Relay Ouputs and check the relay current is < 0.5A DC on each.</p>																			
<p>Activate all used Digital Ouputs and check the current is < 5mA DC on each.</p>																			



Checking Managed AC coupled systems

For systems incorporating Managed AC Coupling the following items should be verified. Please note that “Common System Checks” on page 49 should be completed first.

Refer to relevant installation document for the particular brand of Selectronic Certified grid inverter and ensure the system has been installed and commissioned according to that document before completing the following check list.

- Turn on the DC supply to the SP PRO(s). Long press the ON button so that only the blue AC Load LED is lit.
- Connect SP LINK to the SP PRO inverter(s).
- Connect the AC supply to the Selectronic Certified grid inverters. DO NOT connect the DC supply at this stage.

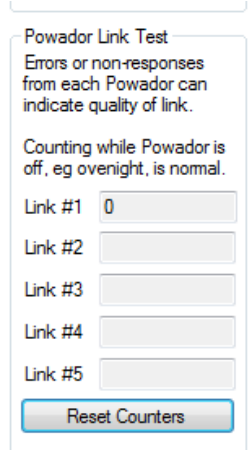

Item to check	Result
For Selectronic Certified Grid inverter #1: • Wake up the #1 inverter as per the relevant installation note. The display should light up. • In the Service Settings tab click the “Reset Counters” button. • Wait 2 minutes then read and record Link #1 (should be <3)	L1 L2 L3
Repeat for L2 and L3 in a three phase of split phase system. For Selectronic Certified Grid inverter #2: • Repeat above for #2 then read and record Link #2 (should be <3)	L1 L2 L3
For Selectronic Certified Grid inverter #3: • Repeat above for #3 then read and record Link #3 (should be <3)	L1 L2 L3
For Selectronic Certified Grid inverter #4: • Repeat above for #4 then read and record Link #4 (should be <3)	L1 L2 L3
For Selectronic Certified Grid inverter #5: • Repeat above for #5 then read and record Link #5 (should be <3)	L1 L2 L3
Where Fallback mode is configured turn on the PV supplies. Unplug the RS485 lead (RJ45) in the SP PRO. Check that each of the connected grid inverter’s output drops to zero after 5 seconds. Repeat for L2 and L3 in a three phase of split phase system.	L1 L2 L3



Checking Generic AC coupled

For systems incorporating Generic AC Coupling the following items should be verified. Please note that “Common System Checks” on page 49 should be completed first.

Refer to document “IN0034_xx SP PRO Generic AC Coupling installation notes” and ensure the system has been installed and commissioned according to this document before completing the following check list.

- Turn on the DC supply to the SP PRO(s). Long press the ON button so that only the blue AC Load LED is lit.
- Connect SP LINK to the SP PRO inverter(s).
- Connect the AC supply to the grid feed inverter(s).
- Turn on the PV supply to the grid feed inverter(s) and let the battery charge from the grid feed inverter(s) until it reaches the charge target voltage.

AC Load Power	0.31 kW
AC Load Voltage	248 V
AC Load Frequency	50.0 Hz

Item to check	Result
When voltage goes above battery charge target check that the AC Load Frequency ramps to 55.2 Hz (No system load, generic inverter is charging)	
When the AC load frequency ramps to 55.2Hz, check that the output from the grid inverters drop to zero and the battery voltage falls.	
Check that the AC load frequency drops back to 50Hz when the battery voltage falls below the charge target.	

Checking DC coupled

For systems incorporating DC Coupled renewable energy the following items should be verified. Please note that “Common System Checks” on page 49 should be completed first.

Refer to relevant document(s) referred to in “DC couple Charge Controller Preparation” on page 34 and ensure the system has first been installed and commissioned according to these document(s).

- Turn on the DC supply to the SP PRO. Long press the ON button so that only the blue AC Load LED is lit.
- Connect SP LINK to the SP PRO inverter.
- Disconnect the battery supply to the DC charge controller(s).

Item to check	Result
Record the “Name” for shunt 1 and 2 (Solar, Wind, Hydro)	1 2
Read the Solar (Wind or Hydro) Shunt 1 current in DataVlew - Now tab. Current should be zero or very close (<0.2 A). Repeat for shunt 2(if connected) - Record the results	1 2
Connect the renewables and battery to the DC charge controller(s) Measure the DC charge current(s) with a DC clamp meter and compare this with the Shunt 1 current. Repeat for shunt 2 (if connected) Record results.	1 2
Let the battery charge from the renewables until FLOAT charge stage is reached on the DC charge controller. Check the Front Panel of the SP PRO to see that its Charging Mode has dropped to FLOAT..	
Put a load on the system until both the SP PRO and the charge controller drop out of FLOAT.	
Turn off the load and let the battery charge back to FLOAT. Again check that the SP PRO has dropped to FLOAT	



Three phase and Split Phase Systems

For systems in a Three Phase or Split Phase Configuration (Multi-phase) the following items should be verified. For ALL multi-phase systems please complete “Common System Checks” on page 49 first.

Please note that based on the system configuration, the following sections should also be completed before proceeding:

- For Managed AC coupled multi-phase - “Checking Managed AC coupled systems” on page 51
- For generic AC coupled multi-phase - “Checking Generic AC coupled” on page 52

Refer to document “IN0016_xx SP PRO Three Phase Installation” for Three Phase or “IN0033_xx SP PRO Split Phase Installation” for Split Phase, and ensure the system has been installed and commissioned according to the relevant document before completing the following check list.

- Turn on the DC supply to the SP PRO inverters.
- Connect SP LINK to all the SP PRO inverters. This can be done by connecting a USB lead from the computer to each SP PRO inverter. Run SP LINK then connect it to L1. Run SP LINK again (a separate SP LINK instance will run) and connect to L2..etc.
- Leave the inverters in IDLE.

Item to check	Result
Read the Shunt 1 current in DataVlew - Now tab for L1, L2 and L3 Current should be zero or very close (<0.2 A). Record the results.	L1 L2 L3
Where a DC Solar shunt (shunt 2) is installed, turn off all DC Souces connected to the shunt 2. Read the Shunt 2 current in DataVlew - Now tab for L1, L2 and L3 Current should be zero or very close (<0.2 A). Record the results	L1 L2 L3
Long press the ON button on L1 so that only the blue AC Load LEDs are lit on all inverters. Place a load on the system that is about 20% - 50% of all inverter capacity. Shunt 1 current = Total load / Batt V (aprox.) Again read the Shunt 1 current in DataVlew - Now tab for L1, L2 and L3. All Shunt 1 currents should be the same and aproximately equal to:- Total load in kW x 1000 / Batt V Record results.	L1 L2 L3
Where a DC Solar shunt (shunt 2) is installed, turn ON all DC Souces and loads connected to the shunt 2. Read the Shunt 2 current in DataVlew - Now tab for L1, L2 and L3 Use a DC clamp meter to measure the Current in Shunt 2. All Shunt 2 currents should be the same and equal to 1/3 the clamp meter reading for three phase or 1/2 the clamp meter reading for split phase.	L1 L2 L3
Turn off the load and connect the AC Source (either Grid or Generator) Check that the system synchronises and the battery bank charges as required.	
FOR DC COUPLED ONLY: Let the battery charge from the solar until it reaches FLOAT charge stage on the DC charge controller. Check the Front Panel of each SP PRO to see that their Charging Mode has dropped to FLOAT	



External AC Source Contactor

For single phase and multi-phase systems incorporating an external AC source Contactor, the following should be verified. Please note that these items are in addition any other items that are relevant to the system configuration.

Please ensure the External AC contactor has been installed and commissioned according to the document “TN0057_xx SP PRO External AC Source Contactor Option” before completing the following check list.

- Turn on the DC supply to the SP PRO(s). Leave the inverter(s) in IDLE
- Connect SP LINK to the SP PRO inverter(s).
- Turn off all charging sources such as any connected AC or DC coupled solar power..
- Turn off the AC source circuit breaker so that there is no AC source connected to the External Contactor.

Item to check	Result
Check that the External AC Source contactor is NOT energised.	
Check the AC Source Voltage in the Data View - Now tab is zero.	
Turn ON the AC source circuit breaker. Check the following: <ul style="list-style-type: none"> • AC Source Voltage reads the source voltage in the Data View - Now tab • The External contactor has turned ON • The AC Load Voltage reads the source voltage in the Data View - Now tab 	
On the front Panel of the SP PRO(s) check: <ul style="list-style-type: none"> • Both the blue AC Source and AC Load LEDs are lit. • The blue Transfer LED is NOT lit. 	
Turn OFF the AC source circuit breaker. Turn ON the SP PRO(s) with a long press of the ON button. Check the following: <ul style="list-style-type: none"> • AC Source Voltage is still zero in the Data View - Now tab • The External contactor is still off • The AC Load Voltage reads 240V in the Data View - Now tab 	
Turn on the AC Source circuit breaker and check the following BEFORE the SP PRO(s) synchronises to the AC Source. <ul style="list-style-type: none"> • AC Source Voltage reads the source voltage in the Data View - Now tab • The External contactor is still off • The AC Load Voltage reads 240V in the Data View - Now tab 	
Check the following AFTER the SP PRO(s) synchronises to the AC Source. <ul style="list-style-type: none"> • AC Source Voltage reads the source voltage in the Data View - Now tab • The External contactor has turned ON • The AC Load Voltage reads the source voltage in the Data View - Now tab 	
Put a load on the system and check the AC source current on each phase with an AC clamp meter. Check the following for each SP PRO: <ul style="list-style-type: none"> • AC Source Current in the Data View - Now tab equals the Clamp meter. • AC Source Power in the Data View - Now tab is a +ve reading. 	



External Generator

For single phase and multi-phase systems incorporating a generator, the following should be verified. Please note that these items are in addition any other items that are relevant to the system configuration.

Please ensure the generator has been installed according to “Adding a Generator (Off Grid)” on page 41 and the document “TN0025_xx SP PRO Generator Controller Wiring Guide” before completing the following check list.

- Turn on the DC supply to the SP PRO(s). Leave the inverter(s) in IDLE
- Connect SP LINK to the SP PRO inverter(s).
- Turn off all charging sources such as any connected AC or DC coupled solar power..
- Turn on the AC source circuit breaker
- Turn on a customer load that is less than 50% but more than 25% of the generator capacity.

Item to check	Result
<p>For auto start generator,..start the generator with a SHORT press on the SP PRO front panel Generator button.</p> <p>If generator does not start then check control wiring and SP PRO configuration settings.</p>	
<p>For manual start generator, Start the generator manually.</p>	
<p>In SP LINK, Data View - Now tab check the “AC Source Voltage” and AC Source Frequency” before the SP PRO syncs to the generator.</p> <p>.Record results</p>	<div style="border: 1px solid black; padding: 5px; width: fit-content;"> <p>AC Source</p> <p>Power 1.56 kW</p> <p>Power (5 min Average) 1.56 kW</p> <p>Voltage 249 V</p> <p>Current 6.5 A</p> <p>Frequency 50.0 Hz</p> </div> <p>Volts</p> <p>Frequ.</p>
<p>Check that the SP PRO syncs to the generator, wait for the “warm up” time (default is 1 min) and check that the generator runs the load and charges the battery bank.</p>	
<p>Wait for the “warm up” time (default is 1 min) and check that the generator runs the load and charges the battery bank.</p>	
<p>Increase the load on the system to more than the generator capacity. Check system is still working OK</p> <p>In SP LINK, Data View - Now tab</p> <ul style="list-style-type: none"> • Check the “AC Source Power”to ensure this is less than or equal to the generator capacity. If wrong then adjust the “AC Source Power” setting in Configuration settings • Check the “AC Source Frequency” to ensure it has not dropped too low (>48 Hz). If too low then drop the “AC Source Power” setting in Configuration settings 	<p>Power</p> <p>Frequ.</p>



Controls and Indicators

Chapter Nine



User Interface

This section lists the controls and indicators found on the front Panel of the SP PRO. The indicator brightness is adjusted according to the ambient light conditions (Blue LEDs exempted).

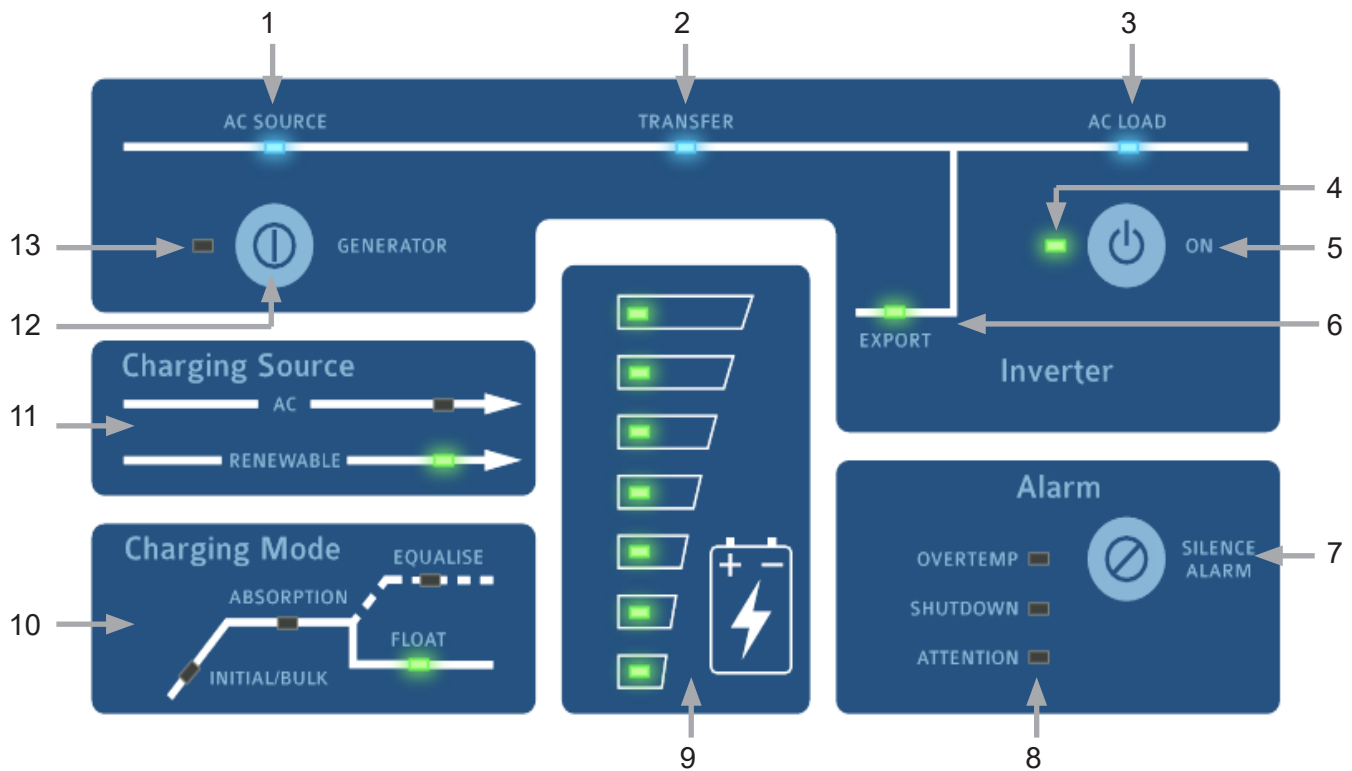

- 1 AC SOURCE ***
When illuminated, this shows the presence of AC supply voltage from either the mains grid or backup generator (when installed), whichever is applicable. This is powered directly from the incoming AC supply.
- 2 TRANSFER ***
Illuminated when an external AC supply is connected through to the AC LOAD output. If AC SOURCE is illuminated but not TRANSFER, it would generally indicate that the AC supply is out of sync tolerance – either the voltage or the frequency is beyond the set limits. It is normal operation for this to flicker slightly. This LED is ALWAYS off with an external AC source contactor.
- 3 AC LOAD ***
When illuminated, this shows the presence of AC voltage ready to supply loads. This is powered directly from the inverter AC output or AC supply.



*Indicators **1,2,3** will operate without any DC connection to the SP PRO. An external AC supply will activate the AC bypass and illuminate these indicators.



4 OUTPUT MODE STATUS

Off	SP PRO Battery supply disconnected. AC bypass only.
Slow flashing Yellow	SP PRO is Idle (off) - Monitoring and logging but no inverter AC output.
Steady Green	The SP PRO is On.
Slow Flashing Green	SP PRO Econo mode is active and is sensing load conditions.
Fast Flashing Green	SP PRO is preparing to start.
Steady Red	Indicates that a Fault has been detected and no inverter output is possible.
Flashing Red	Indicates an open circuit or poor battery connection and no inverter output is possible.
Slow Flashing Red	Inverter has not been configured using SP LINK . No inverter output is possible.

5 ON BUTTON

A LONG PRESS (>1 second) - turns the SP PRO On. Another long press SP PRO reverts to Idle.
 A SHORT PRESS (<1 second) - activates Econo mode (Not available in 120 VDC models)

6 EXPORT

Indicates that the SP PRO is feeding power to the grid: On, exporting to the grid and supplying AC Load;
 Flashing, supplying the AC Load only, no export to grid.

7 SILENCE ALARM BUTTON

Turns off the audible alarm for this instance only. Alarm will resound with a new alarm condition.

8 ALARM INDICATORS

OVERTEMP

Yellow	SP PRO is approaching an over temperature condition
Red	SP PRO has shutdown due to an over temperature condition

SHUTDOWN

Yellow	SP PRO is approaching a shutdown condition
Red	SP PRO has shutdown

ATTENTION

Off	Normal
Yellow	Attention Required, Fan Service Request
Flashing Yellow	Either Clean Fan, Fan Fault or Capacitor Bank Service Request
Red	Immediate Attention required
Flashing RED	Unit Fault

See Attention Required in SP LINK Data View - Now section to determine specific reason for the attention indicator.

9 BATTERY “FUEL” GAUGE

These indicate the battery State of Charge (SoC). When the battery SoC is equal to the Shutdown SoC (in Configuration Settings - Inverter tab) then only the bottom LED is green. At 100% SoC all LEDs are green.

Top Indicator Flashing RED	Instant Hi DC Voltage Shutdown. Battery or battery wiring fault
Bottom Indicator Yellow	Low Battery. Battery needs charging
Bottom Indicator Red	Low Battery Shutdown. Inverter has shut down due to flat battery
Bottom Indicator Flashing RED	Instant Low DC Voltage Shutdown. Battery or battery wiring fault.
All Indicators flashing RED	Inverter in emergency Low DC Shutdown Override (See SP LINK Manual)

10 CHARGING MODE

The Charging Mode panel indicates the present charging state. See “Battery Charging Operation” on page 60.

11 CHARGING SOURCE

AC - On.	Power from the AC Source input supply is charging battery bank (Grid or generator)
Renewable - On	Power from any monitored renewable energy supply is charging battery bank

12 BACKUP GENERATOR BUTTON & EQUALISE REQUEST

A short press	Start or stop the backup generator (where installed)..
Two long presses	Set or cancel an Equalise charge request. EQUALISE Indicator will flash. Next time charger reaches FLOAT an EQUALISE charge will be performed.

13 BACKUP GENERATOR STATUS

Off	No backup generator activity
Flashing Green	Generator is in the process of starting
Steady Green	Generator has started and is running
Flashing Yellow	Generator is not available for auto start
Flashing Red	There is a generator fault

NOTE: Button **12** and LED **13** are not active when a backup generator is not installed.



SP PRO Operation



Chapter Ten

The following section describes in detail the operation of the SP PRO. A good understanding of the operation of the SP PRO and its parameters will enable configuration of the SP PRO to meet the system design requirements.

The SP PRO Battery management continuously monitors the system operation. This monitoring allows the SP PRO to ensure the batteries are correctly charged to maximise system reliability. The monitoring includes any input from renewable sources (AC or DC Coupled) and any loads directly connected to the battery bank.

The SP PRO uses a five stage temperature compensated battery charging system. This system gives a high degree of flexibility so it can charge the multitude of battery types available.

Also incorporated are a number of “time of day” and “day of week” schedules. These schedules can be set to meet the cheapest electricity rates or reduce high load demands from the grid.



WARNING: This equipment must be used in accordance with the instructions in this manual and any other related documents. If this equipment is used in a manner not specified by the manufacturer as contained in this manual and other operational documents and Instructions, then the protection provided by the equipment may be impaired.

DO NOT remove any covers. There are no operator accessible parts within the SP PRO.



Battery Management



Please refer to the battery manufacturer’s documentation for recommendations regarding settings for the particular battery. Inappropriate settings may have a detrimental affect on the battery life and performance.

The SP PRO provides comprehensive battery management settings and control to allow a charge regime to achieve optimal battery life.

SP PRO battery management features include:

- State of Charge monitoring and control.
- Battery terminal voltage monitoring (Battery Sense / pre-charge) and control.
- Charging initiated by battery state of charge and/or battery voltage.
- Five stage charge cycle: Initial, Bulk, Absorption, Float (short term and long term) and Equalise.
- Shutdown on low battery voltage, battery state of charge, or both.
- Two stage Battery Temperature compensation of charging voltage based on battery temperature.

The SP PRO may be configured to use the Grid power or to automatically start a backup generator (with Grid Fail - Generator Backup Option) when a battery charge cycle is required during a prolonged grid outage.

Battery State of Charge (SoC) monitoring and control

For SoC control to function correctly all DC battery currents, other than the inverter current, must be monitored on either or both of the two current shunt inputs to the SP PRO. No current shunt is required to read the SP PROs current or any AC Coupled supply as this is read internally. The resultant battery current is monitored to track the battery SoC which is expressed as a percentage of the battery size set in the SP PRO (Battery Capacity).

The accuracy of the battery SoC is limited by a number of factors including the charge and discharge efficiency of the battery bank. To improve the accuracy of the battery SoC calculation, the SP PRO employs an adaptive algorithm to constantly update a “charge efficiency index” which is used during recharge.

In an Off Grid system where a Generator is installed, the state of charge is used to automatically start the generator as required. The generator will then supply the load while any excess available generator capacity will charge the batteries.

In a Solar Hybrid system, the state of charge along with time of day and load demand is used to vary the priority and direct the renewable energy to either power the AC load, recharge the battery bank and/or export to the grid. This allows for the maximum use of the renewable energy (such as PV solar) whilst taking advantage of variable electricity tariffs

Battery Voltage monitoring and control

The SP PRO measures the battery voltage both at the inverter and also directly at the battery bank using the Battery Sense / pre-charge wiring (if installed). Sensing the actual battery terminal voltage (using Battery Sense / pre-charge wiring) compensates for the effect of cable losses which, irrespective of charge or discharge currents, keeps the battery terminal voltage within set limits.

Battery voltage is used to protect the system by shutting the unit down should the battery voltage go above or below set limits. The shutdown limits must be set to higher than the maximum charge voltage. For the low voltage shutdown limits the SP PRO employs different levels depending on system load. The system will always attempt to reconnect to the grid or start the backup generator (when installed) before shutting the inverter down due to low battery voltage or SoC.



Battery Charging Operation

The SP PRO charging system manages all charging sources in the power system giving priority as appropriate to the renewable energy sources. This ensures that the renewable sources are used in the most cost effective manner.

The SP PRO continuously monitors all charging sources to recharge the battery in a five-stage cycle. Each stage or Charging Mode is controlled by voltage, current and time settings. These settings are fully configurable using SP LINK and should not require changing after initial installation, unless some aspect of the battery installation changes.

Each voltage setting is battery temperature compensated. The set values displayed do not change. See Battery Temperature for details.

BATTERY CHARGING MODE.

Read the following with reference to the Battery Charging Cycle graph on the following page.

INITIAL

The SP PRO charges at the initial charging current until the battery voltage rises to the initial charge voltage, then holds this voltage for a set time before starting the Bulk stage. When in the Initial charge phase, the Initial/Bulk indicator will flash.

BULK

The SP PRO charges at the bulk charging current until the battery voltage rises to the bulk charge voltage, then holds this voltage for a set length of time, before starting the Absorption stage. In Bulk charge mode, the Initial/Bulk indicator will be steady ON.

ABSORB

In the Absorption charge phase the SP PRO will charge at the absorb charge current until the absorb charge voltage is reached. Once this voltage is reached, the SP PRO will carefully monitor the rate of change of the charge current as set in the Absorb-Float transition setting.

When the Absorb-Float transition setting is met, the charge cycle will switch to Float and terminate an auto start backup generator if connected. If an Equalise charge is pending, the Equalise charge cycle will now be performed. The Absorption indicator will be steady on when in the Absorption phase.

FLOAT

The SP PRO holds the battery voltage at the Float level and will provide up to the float current to maintain the float voltage. The SP PRO will remain in this charge state until battery voltage falls below the Initial Return level. If the SP PRO is still connected to an AC Source after 24 hours of Float, the charger will transition to the Long Term Float voltage. Long Term float voltage will allow batteries to sit at a lower voltage level indefinitely, reducing battery losses.

EQUALISE

Periodically, the SP PRO performs an equalise charge in which the battery is held at a higher voltage for a period set in the EQUALISE window. This will help ensure all cells within the battery bank have an equal amount of charge. The equalise indicator will be steady on when in equalise mode and will flash when an equalise is pending, that is the charger will perform an equalise after float stage is next reached.



Note on Battery Charging: Lead acid batteries (such as GEL, Flooded, AGM, VRLA) normally start to take less charge when they reach 80% State Of Charge (SoC) and above. It is normal to see the Charge Current reducing and excess PV solar being exported or PV controllers (including managed AC coupled solar) power limiting when the batteries reach 80% SoC.

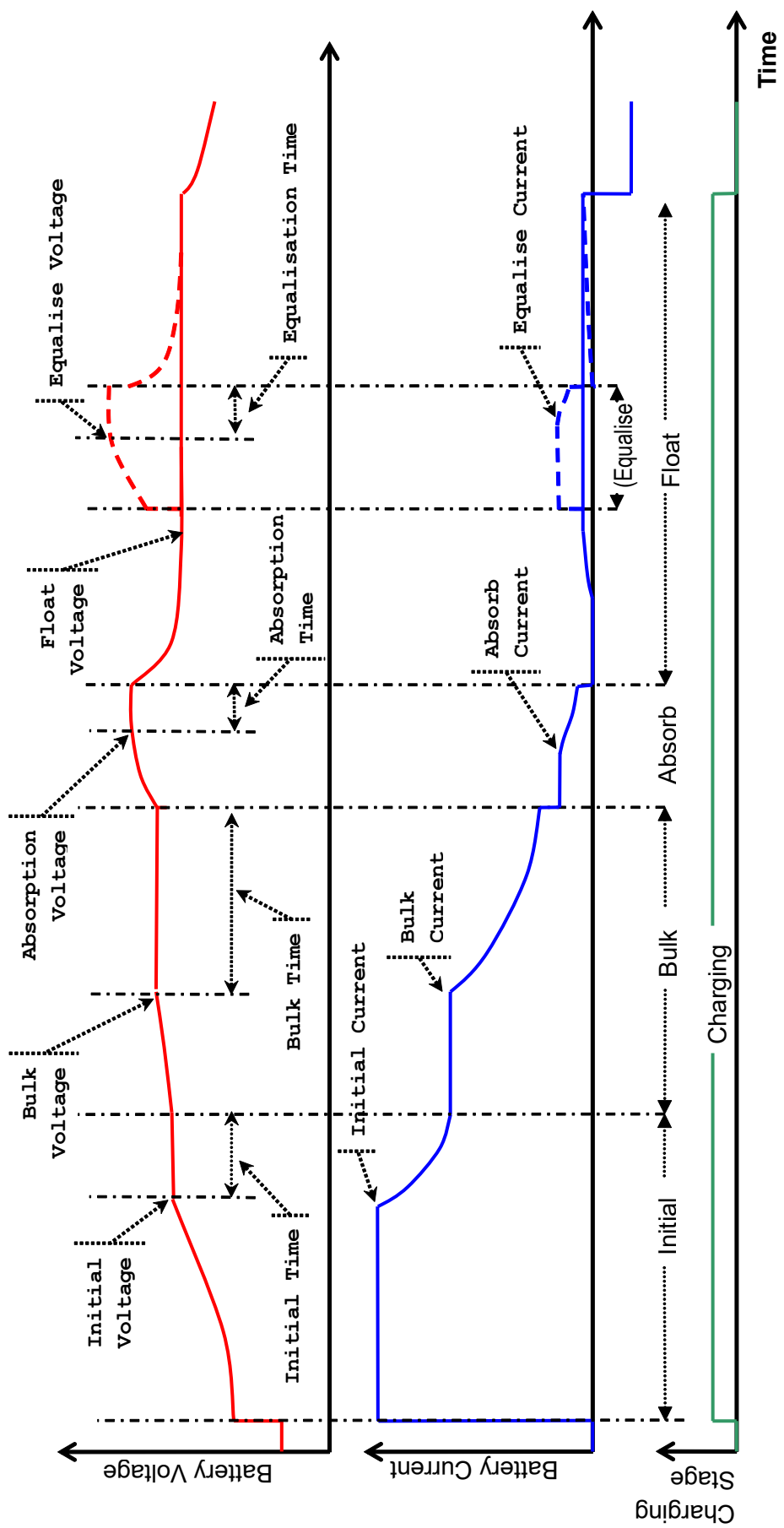

Battery Charging Cycle



Battery Temperature Compensation

The SP PRO monitors the battery temperature via the sensor provided. The supplied battery temperature sensor must be mounted in thermal contact with the centre of the side of the battery. If the sensor is not in thermal contact with the battery bank the batteries will not be correctly charged. Check battery temperature is reading correctly in the Temperature Control section of Technical Data in SP LINK.

The charge voltage set points are compensated by battery temperature. The default compensation applied is -5.5 mV/°C/cell with zero compensation at 25°C.

e.g. Initial Voltage = 55.2, Battery Temperature = 26°C, No. Battery Cells = 24.
Compensated Charge voltage = $55.2 + ((26 - 25) \times -0.0055 \times 24)$
= 55.07

Absorption Voltage = 57.6, Battery Temperature = 6°C, No. Battery Cells = 24.
Compensated Charge voltage = $57.6 + ((6 - 25) \times -0.0055 \times 24)$
= 60.11

During all charge stages, the compensated charge voltage will not exceed Max Voltage Limit. Compensation improves battery performance by preventing over or undercharging the battery and protects against battery overheating.

The charge current is also limited by battery temperature. Battery temperatures above 45°C cause the battery charger to reduce the charge current limit point. This will help also help protect the battery from overheating.



The temperature compensated charge voltage target and charge current target at any point in time can be viewed in SP LINK under the Data View -Technical Data tab, "Target Charge Voltage" and "Target Charge Current".

Renewable Management

SOLAR HYBRID -GRID AVAILABLE

In Solar Hybrid, the renewable energy can be directed to power the AC load, recharge the battery bank and/or export to the grid. The direction and priority of the energy flow can be varied dependant on the time of day, battery SoC or load demands allowing the maximum use of the renewable energy (such as PV solar) whilst taking advantage of variable electricity tariffs.

SOLAR HYBRID -GRID OUTAGE

When the grid fails the SP PRO feeds renewable power to the AC load, and any excess is stored in the battery for later use. If the battery is fully charged and all loads are being supplied, the renewable power is backed off (DC coupling or managed AC coupling) or disconnected (Generic AC coupling) to prevent overcharging of the batteries

OFF GRID SYSTEMS

In an Off Grid System the SP PRO feeds renewable power to the AC load, and any excess is stored in the battery for later use. If the battery is fully charged and all loads are being supplied, the renewable power is backed off (DC coupling or managed AC coupling) to prevent overcharging of the batteries



Generator Controls for Off Grid

The SP PRO may be configured to automatically control a generator in an Off Grid power system. The generator control is standard with all SP PRO models

The SP PRO Configuration Settings can be configured to automatically run the generator during periods of insufficient renewable energy production to:

- Limit the depth of battery discharge, for maximum battery life.
- Deliver energy efficiently by supplying sustained large loads direct from the generator.
- Load the generator to the highest possible level while running, to efficiently convert fuel to electricity.
- Limit generator starting frequency, which would reduce its life and increase maintenance.
- Avoid noise by only starting the generator late at night for heavy loads or a deeply discharged battery.

For full details on backup generator controls please see “TN0025_xx SP PRO Generator Controller Wiring Guide” available on the supplied USB stick or from the Selectronic web site.

Backup Generator Controls (with option)

The SP PRO may be configured to automatically control a backup generator in a Solar Hybrid power system using the optional “Grid fail - Gen backup” module. During a grid outage the generator will be automatically started by the SP PRO as required to supply the load and charge the battery bank.

As part of the installation, the SP PRO settings are configured to automatically run the generator during a grid outage to:

- Limit the depth of battery discharge, for maximum battery life.
- Deliver energy efficiently by supplying sustained large loads direct from the generator.
- Load the generator to the highest possible level while running, to efficiently convert fuel to electricity.
- Limit generator starting frequency, which would reduce its life and increase maintenance.
- Avoid noise by only starting the generator late at night for heavy loads or a deeply discharged battery.

For full details on backup generator controls please see the documentation supplied with the optional Grid Fail - Generator Backup option.

Inverter External Alarm

The SP PRO provides an alarm output which can be wired to an external alarm buzzer or light. A shutdown alarm is indicated by a continuous ON condition and an alert alarm is indicated by a slow intermittent ON/OFF condition. The SP PRO is in alarm state when shutdown or idle. The alarm relay is active in the normal or no alarm state condition (i.e. use the NC relay contacts to run an alarm buzzer or indicator). Alert conditions can be prevented from raising the alarm, via SP LINK.



Service and Maintenance



Chapter Eleven

Multiple Sources of Supply



Hazardous voltages and energy is generated by and are fed into the SP PRO by external wiring from multiple sources and may be stored in capacitors after switched off. Ensure the isolation of all energy sources. including AC source isolator, battery main isolator, battery precharge isolator and all renewable energy sources including solar, wind and hydro before carrying out maintenance on the SP PRO. A time of at least 5 minutes must elapse AFTER the disconnection of the battery main isolator and the battery precharge isolator before any trained technical staff gain internal access to the SP PRO

Cleaning the Fan and Fan filter

1. Ensure fan is stationary
2. Remove the four retaining screws that hold the fan filter in place.
3. Clean the filter mesh with a soft brush or similar implement.
4. Check to see if there are any foreign matter that could impede the fan operation.
5. Replace filter and tighten the four retaining screws.

All other maintenance on the SP PRO should be performed by a Selectronic Accredited Integrator.



Above the fan filter is a safety grill. Do not remove this grill – fast moving fan blades can cause injury

Monitoring the Operation of the SP PRO

Installing SP LINK software onto a PC also installs SP LINK Auto QuickView. This program is a shortened version of SP LINK designed to automatically connect to and display information about the SP PRO.

Using this program allows the following items to be monitored on a regular basis:

- BATTERY VOLTAGE (QuickView Tab)- this should NEVER be below the nominal system voltage - 24 V, 48 V or 120 V
- BATTERY SoC% (QuickView Tab) - a high average figure will maintain good battery life
- The AVERAGE DAILY ENERGY SUPPLIED to the load (Data View - Today Tab) is within design parameter.
- PERFORMANCE DATA EVENTS. - Download performance data in the Performance Data Menu.
- SERVICE REQUIRED - Check the Attention Required box in the Data View - Now Tab. Right click this to open the SP LINK manual which contains a list of messages and the actions required.



System Shutdown

The Installer / integrator will provide detailed Shutdown and Restart instructions specific to the installation.

Installer Maintenance of SP PRO

Other than ensuring all AC and DC connections are always tight, there are only three areas that may require maintenance.

- FAN ALERT – This can be checked in the “Now” tab of the “Data View” section. A fan alert generally indicates that the fan is stationary when it should be running. This will mean that either the fan needs replacement or that a foreign body is stuck in the fan. Also see “” on page 64
- FAN LIFE is recorded in the “Technical Data” section of the “Data View” tab. Fan life is expressed in the percentage of fan life used i.e. The figure starts at 0% and rises the longer the fan runs. As fan life is projected to be in excess of 40,000 hours quite a high percentage of fan life can be used before replacement is necessary.
- CAPACITOR LIFE is measured on both halves of the power module and is expressed, as before, in percentage of life used. The power module should be replaced when capacitor life, in either half, reaches 95%.



There are no user serviceable or replaceable parts within the SP PRO. Any maintenance, other than fan filter cleaning, should be performed by a Selectronic Authorised Integrator.

System Maintenance

A Selectronic Accredited Integrator will provide the maintenance that is required for the balance of the system components.

Battery Maintenance and replacement



Batteries are a hazardous part of the power system. Servicing and replacement of batteries must be performed by suitably qualified personnel knowledgeable about batteries and the required precautions.

When replacing batteries in the system ensure that they are replaced with the same type and number of batteries as the original system. When removing or replacing batteries please ensure that the battery manufacturer’s recommendations and instructions are followed.



CAUTION: Do not dispose of batteries in a fire. The batteries may explode.
CAUTION: Do not open or damage batteries. Released electrolyte is harmful to the skin and eyes. It may be toxic.

CAUTION: A battery can present a risk of electrical shock and high short-circuit current. The following precautions should be observed when working on batteries:

- Remove watches, rings, or other metal objects.
- Use tools with insulated handles.
- Wear rubber gloves and boots.
- Do not lay tools or metal parts on top of batteries.
- Disconnect charging source prior to connecting or disconnecting battery terminals.
- Determine if battery is inadvertently grounded. If inadvertently grounded, remove source from ground. Contact with any part of a grounded battery can result in electrical shock. The likelihood of such shock can be reduced if such grounds are removed during installation and maintenance



Troubleshooting



Chapter Twelve

The SP PRO provides advanced monitoring of the power system and will advise the user when a problem develops with the power system. In most cases the problem and its cause can be determined by using the indicators provided with the SP PRO and information available via SP LINK.

Front Panel Indicators

The first and easy step is to look at the front panel of the SP PRO. If all the LEDs are green then all is well and the system components that are measured or controlled by the SP PRO are functioning correctly.

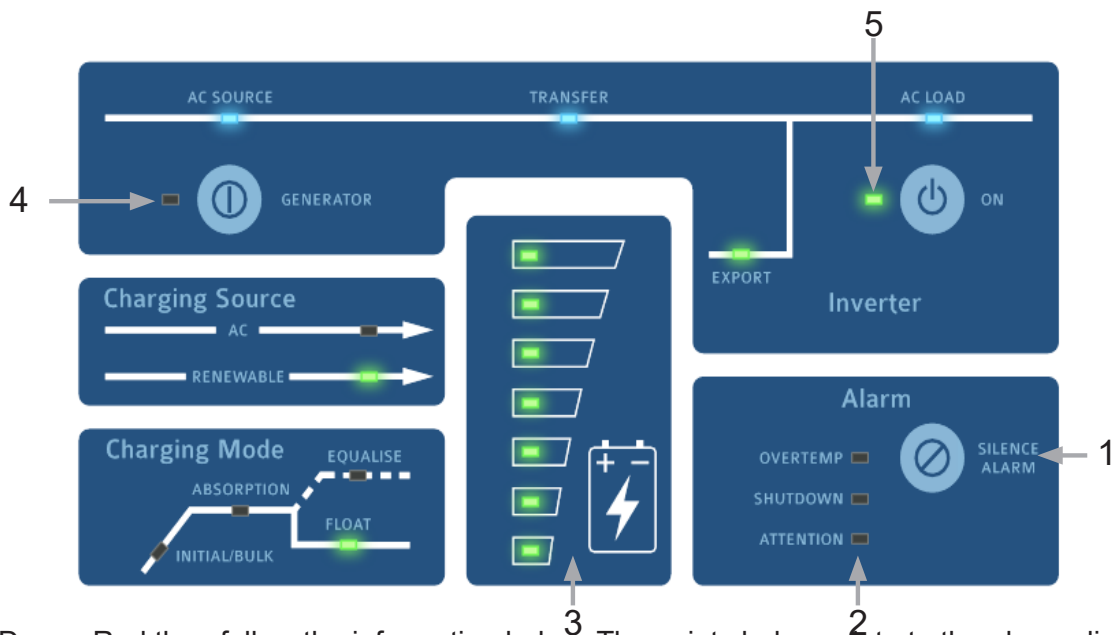

If any LEDs are Red then follow the information below. The points below relate to the above diagram.



1. Alarm Silence button - When the SP PRO detects an alert condition within the power it will sound its internal audible alarm. Pressing this button will silence the alarm for this instance only. Alarm will resound with a new alert condition

2. Alarms

OVERTEMP

- Yellow SP PRO is approaching an over temperature condition due to high loads, high ambient temperatures or obstructed cooling air flow.
- Red SP PRO has shutdown due to an over temperature condition caused by high loads, high ambient temperatures or obstructed cooling air flow.

Solution

1. Reduce the load on the system
2. Check and clear fan or fan filter. See "" on page 64

SHUTDOWN

- Yellow SP PRO is approaching a shutdown condition
- Red SP PRO has shutdown

Solution See next section "Troubleshooting with SP LINK" on page 68

ATTENTION

- Off Normal operation - System is operating normally
- Yellow Attention Required, Fan Service Request. See "" on page 64
- Flashing Yellow Either Clean Fan, Fan Fault or Capacitor Bank
- Red Immediate Attention required.
- Flashing RED Unit Fault.

Solution See next section "Troubleshooting with SP LINK" on page 68

3. Battery Indicator

- Top LED Flashing RED Instant Hi DC Voltage Shutdown. Battery or battery wiring fault
- Bottom LED Yellow Low Battery. Battery needs charging
- Bottom LED Red Low Battery Shutdown. Inverter has shut down due to flat or faulty battery
- Bottom LED Flash RED Instant Low DC Voltage Shutdown. Battery or battery wiring fault.

Solution

1. Give battery bank a full charge and equalise charge.
2. Check all battery wiring including the battery bank interconnections, connections at the DC fuse or CB and the main battery connection to the SP PRO.
3. Check all battery sense/pro-charge wiring.
4. Check for faulty or failed cells withing the battery bank.

NOTE: When all LEDs are flashing RED the inverter has been put in Low DC Shutdown Override by the user. In emergency situations, this override enables the SP PRO to be forced to work beyond the battery shutdown limits. The SP PRO will continue to operate at reduced capacity until the battery can no longer supply enough power to keep the inverter and loads running. Please remember that this feature should only be used in an emergency as it overrides the SP PRO normal battery shutdown protections and may damage the batteries or connected equipment.

4. Generator

- Flashing Yellow Generator is not available for auto start. The "Generator Available signal" is not active. See next section "Troubleshooting with SP LINK" on page 68
- Flashing Red There is a generator fault

Solution

1. Check the Generator Available signal.
2. Check the generator and clear the fault
3. Try and start the generator manually.

5. ON

- Slow Flashing Red Inverter is not configured and will not start.

Solution Configure inverter using SP LINK

Troubleshooting with SP LINK

If any of the LED indicators are ON or Flashing RED or ORANGE and the problem cannot be easily found, more information about the alert condition can be found by taking the following steps.

- Run SP LINK and connect to the SP PRO.
- Go to the Data View - Now tab and view the messages in the “Attention Required” box.
- Right click the “Attention Required” heading to go to the SP LINK manual. The manual lists all the SP PRO alerts, the likely cause and possible remedies.

If more in depth information about the power system or further assistance with the system issues is required::

- Go to the Performance Data menu in SP LINK and select “Download All”.
- After the download is complete, run the Performance Data Viewer and click on the “Events” sheet.
- Look for any “ALERT” events to determine the system issues.
- If more information is required about the “ALERT” message go to the Data View - Now tab in SP LINK and right click the “Attention Required” heading to go to the SP LINK manual. The manual lists all the SP PRO alerts, the likely cause and possible remedies.

If further assistance is required then email the zip file in the Download to the System Integrator or to a Selectronic Accredited Integrator.

An Accredited Integrator has direct knowledge of the system components, the load profile and SP PRO configuration which affect the behaviour and operation of the SP PRO. Accredited Integrators have been trained in the operation of the SP PRO and the configuration of the units to meet the requirements of each installation.

NOTE: The SP PRO contains a very large amount of Performance Data to allow troubleshooting of any system or inverter issues, most are NOT an inverter failure. If the power system is not functioning as required then the system designer should review the Performance Data stored within the SP PRO. See the Using SP LINK and Performance Monitoring section within the SP LINK manual for further information. Using the Performance Data Viewer within SP LINK, every aspect of the system and SP PRO can be analysed. If required, Selectronic can provide a second opinion (charges may apply) of the Performance Data.

Further information can be found at www.selectronic.com.au

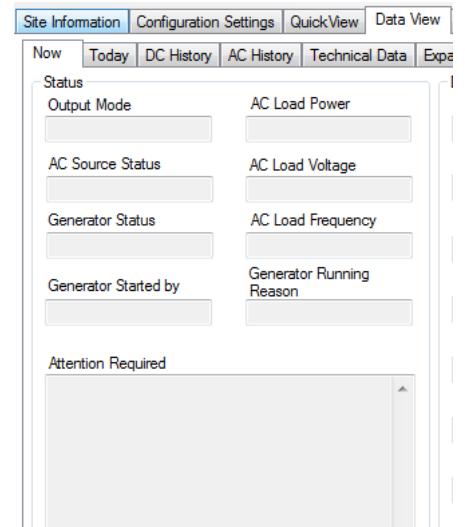



AC Power Problems

If the power fluctuates, lights go bright or dim but don't go out.

- Check the SP PRO front panel indicators and Performance data for information on the cause.
- The SP PRO output may be varying due to starting very heavy loads. Check the output voltage reading (AC Load Voltage) via SP LINK.

If the power goes off for short periods (1 second to a few minutes)

- Check the SP PRO front panel indicators and Performance Data for information on the cause.
- The SP PRO may be in Power Save mode and the load is too small to detect. In this mode the SP PRO pulses the output until a load is detected. Check the Econo Power Level in SP LINK.
- The SP PRO may be shutting down due to overload or low DC voltage and periodically attempting restarts. If the SP PRO is shutting down switch off any heavy loads that may be causing the shut down.

If the power goes off for longer periods (10 minutes to many hours)

- Check the SP PRO front panel indicators and Performance Data for information on the cause.
- Check the Attention Required window in the Now tab in Data View section of SP LINK to see if a fault is indicated and contact the supplier for further instructions.

Battery Problems

Batteries are very dangerous. Please read the safety information provided by the battery supplier.



Battery does not charge properly

- Check that the battery charging requirements are correctly set up in the SP PRO.
- Check that the solar regulator is correctly set up.
- Check all cables and connections to the batteries.

If the solar does not appear to be doing much, the solar regulator may be set too low. Check indicators and DC History in SP LINK.

If the battery is not operating correctly:

- Physically inspect the battery and check for loose connections. Monitor the battery voltage as heavy loads supplied by the SP PRO are turned on and off.
- Check the voltage on each battery making up the battery bank to see if there are cells not fully charged or not accepting charge. Measure voltages on each cell/battery at different times in the charge discharge cycle. Just after charge has started say after 10 minutes, in mid charge, just before end of charge, ten minutes after discharge starts, mid discharge and just before recharge starts.

Grid related Problems

GRID AVAILABLE BUT POWER IS LOST

- The likely cause is the SP PRO has disconnected from the grid due to high voltage or frequency, leaving the site to operate from the limited battery storage. To resolve, widen the "Sync Tolerance" parameters or contact the electricity supplier.

DC COUPLED SOLAR SYSTEM THAT DOESN'T EXPORT AS EXPECTED

- The likely cause is the Solar Controller (external device to the SP PRO) is restricting the flow of power from the PV array. To resolve, make sure the Solar Controller float charging set point is ~ 1 V higher than the SP PRO Float stage set point. and the charge stages are linked. See "DC couple Charge Controller Preparation" on page 34



Off Grid Generator Start/Stop Problems

Daily patterns of generator operation will change as the load supplied each day changes and as any renewable input such as solar increases or decreases from day to day or season to season.

Using SP LINK check the “Generator Running Reason” section of the “Now” tab of the “Data View” section.

If the reason does not seem to relate to what is actually happening in the system consult a Selectronic Authorised Integrator.

IF THE GENERATOR RUNS MORE OFTEN THAN NORMAL OR EXPECTED:

There are several possible causes:

1. The system average load has increased:

Using SP LINK check the “7 DAY DAILY AVERAGE” figure in the “AC LOAD ENERGY” section of “AC HISTORY” within the “DATA VIEW” tab and compare it with the value displayed when the system was operating satisfactorily.

Using SP LINK compare the “7 DAY DAILY AVERAGE” figure in the “AC LOAD ENERGY” section of “AC HISTORY” within the “DATA VIEW” tab against the system design value which should have been supplied by the installer.

If loads have significantly increased, identify any new electrical equipment that has been added

2. The system peak loads are very high:

Using SP LINK check the POWER and the POWER (5 MIN AVERAGE) in the AC SOURCE area in the NOW tab of the DATA VIEW section while operating any new appliance that has been added to the system. The associated On 5 Load power and the On 15 minute load power setting in the GENERATOR AUTO RUN TAB may need adjustment by the integrator.

3. The load during late night and early morning periods is higher than expected but not high enough to keep the generator running permanently. There may be multiple starts and stops as the battery becomes discharged and is partly recharged:

Increase the generator minimum run time to increase the amount of battery recharge before stopping, hence reducing the number of starts and stops.

4. The battery is not operating correctly.

If the generator runs longer than normal or expected:

This is generally because system load has increased or the renewable input from solar has decreased. It could also be because the battery efficiency has fallen off with age or cell failure in the battery.

Use the Performance Data Events to establish load levels and reasons for generator starts and stops.

Use the Data View menu to check measured values, particularly the accumulated battery energy in and energy out totals. These will have to be compared over a week to see the change in the accumulated values.

The SP PRO may be performing an Equalise charge which can take some hours to complete; check if the Equalise indicator is illuminated.

There may be a sustained load on the system. Check to see that appliances have not been left on. The Now, Today and AC History sections of the Data View tab provide information regarding the load power. Check the generator schedule settings.

If the generator restarts a minute or so after it last stops then the battery is discharged, the battery volts are low, or a load is present. Check the Now section of Data view to see the Generator Running Reason. The generator can be shut down permanently by setting the generator to NOT available, or Generator Controller to Disabled.

Inverter Startup Problems

SP PRO WILL NOT START

If the indicators remain dark (Not including the 3 blue LEDs along the top) when the SP PRO is switched on it is likely that DC battery power is not present. Check all the main battery wiring, terminal and that the main battery fuse or circuit breaker is closed. Retry the start up procedure and if the problem continues contact the installer for further instructions.

Resetting inverter with or without Restoring Factory Default settings

The following procedure will reset the inverter without restoring factory defaults OR reset the inverter and restore factory defaults for either Flooded batteries or Sealed batteries - .

Set SP PRO in Idle mode with a long press of the ON button (On LED flashing amber)

- To Reset inverter **WITHOUT** restoring defaults, press and hold buttons B as shown, all indicators will go off. Release buttons B and inverter will reset.
- To Reset inverter **AND** restore factory defaults, press and hold buttons B as shown, all indicators will go off. Whilst continuing to hold B, press C to select from following options -
 - Press C once. All LEDs Green = Flooded battery defaults
 - Press C twice. All LEDs Red = Sealed battery defaults
 - Release all buttons, wait 10 seconds until display is stable.





Appendix A Specifications



Appendix

Standards Compliance

IEC 62109-1 Ed. 1.0	Safety of power converters for use in photovoltaic power systems - Part 1 General requirements
IEC 62109-2 Ed. 1.0	Safety of power converters for use in photovoltaic power systems - Part 2 Particular requirements for inverters
AS62040.1.1-2003	Uninterruptible power systems (UPS) - General and safety requirements for UPS used in operator access areas
AS/NZS 61000-6-3:2007	Electromagnetic Compatibility (EMC) - Part 6-3: Generic Standards - Emission Standard For Residential, Commercial And Light-industrial Environments
AS/NZS 61000-6-4:2007	Electromagnetic Compatibility (EMC) - Part 6-4: Generic Standards - Emission Standard For Industry
AS/NZS 4777.2-2015	Grid connection of energy systems via inverters - Inverter requirements
C-tick Australia	

Product Specifications



Note: Selectronic reserve the right to change specifications without notice.
All ratings are at 25°C and nominal battery voltage unless otherwise stated. The product is
specified to a maximum altitude of 2000 metres.



SP PRO SERIES SPECIFICATIONS		SPMC240	SPMC241	SPMC481	SPMC482	SPMC1201	SPLC1200	SPLC1202	
Nominal battery voltage		24 V	24 V	48 V	48 V	120 V	120 V	120 V	
Continuous, output power	@ 25°C	3,000 W	4,500 W	5,000 W	7,500 W	7,500 W	15,000 W	20,000 W	
Continuous inverter AC current		12.5 A	18.8 A	20.8 A	31.3 A	31.3 A	62.5 A	83.3 A	
Continuous, DC charge current		125 A	188 A	104 A	156 A	63 A	125 A	167 A	
Continuous grid export power		rated output							
10 second load rating 10 second output current	@ 40°C							44,000 W 180 A	
20 second load rating 20 second output current	@ 40°C	7,500 W 28 A	10,500 W 40 A	12,000 W 47 A	18,000 W 70 A	18,000 W 70 A	33,000 W 135 A	38,000 W 155 A	
1 minute output power	@ 40°C	5,400 W	7,600 W	8,700 W	13,000 W	13,000 W	26,000 W	35,000 W	
60 minute output power	@ 40°C	3,200 W	4,700 W	5,300 W	8,000 W	8,000 W	18,000 W	24,000 W	
DC input voltage range		20 - 34 V	20 - 34 V	40 - 68 V	40 - 68 V	100 - 170 V	100 - 170 V	100 - 170 V	
TRANSFER SWITCH (Synchronous)									
AC transfer current capacity				63 A		125 A		125 A	
Max AC input source, (generator/grid)				15 kVA		30 kVA		30 kVA	
Max total output to Load, AC source + inverter				15 kVA		30 kVA		30 kVA	
AC transfer time				no-break					
If grid fails				0 - 0.03 seconds					
Battery charger type				Temperature compensated, 5 stage, power factor corrected with dual stage float					
EFFICIENCY									
DC consumption idle		6 W							
DC consumption standby (Econo Mode)		12 - 20 W				n/a			
ON with no load		25 W	33 W	35 W	43 W	43 W	89 W	90 W	
Peak efficiency – all modes		95%	95%	95.5%	96%	96.5%	97.2%	97.2%	
10% load		90%	90.5%	91%	91%	91.5%	93.3%	94.8%	
20% load		92.5%	93%	94%	94%	94%	95.8%	96.8%	
50% load		94%	94.5%	95%	95.5%	96%	97.2%	97.1%	
100% load		90%	91%	92.5%	93%	93.5%	96.8%	95.5%	
AC OUTPUT (standalone)									
Range		210 to 240 V +/- 0.5%							
Power Factor Range		0.1 to 1.0 leading or lagging							
maximum AC fault current (RMS)		35A	52A	58A	86A	86A	175A	230A	
over current protection rating (Required to be installed external to inverter)		63 A					125 A		
Decisive Voltage Class		C							
Regulation		<1% droop 0-100% rated load (<2% @ 150%, <5% @200%)							
THD		<3% @ 0-200% rated load							
Frequency		50 or 60 Hz +/-0.005% standalone							
AC SOURCE (input)									
Nominal voltage		240 V~							
AC current (Recharge, Bypass & Normal modes)		63 A					125 A		
Tolerance on nominal voltage		Configurable 204 to 264 V~							
over current protection rating (Required to be installed external to inverter)		63 A					125 A		
Decisive Voltage Class		C							
Nominal input frequency		50/60 Hz							
Tolerance on nominal frequency		Configurable +/- 1% to 10%							
Active Anti-Islanding method		LF impedance measurement							
Generator can be started by		Battery SoC, DC voltage, battery load, unit temperature, time & remote control							
Disconnection and Isolation									
Disconnection and isolation of SP PRO		The SP PRO must have external disconnect devices installed on all three power ports, AC Output (AC Load), AC Source and Battery port. To disconnect and isolate the inverter, all disconnect devices on all three ports must be in the OFF position.(disconnected)							
Inverter Demand Response Modes (DRM)									
Demand Response modes available		DRM0 is available in the SP PRO. To enable DRM0 configure the SP PRO according to the instructions contained in the optional DRM0 kit, stock code 005239							

All specification at 25C and Rated DC input voltage unless otherwise stated.
Specifications may change without notice.



...SP PRO SERIES SPECIFICATIONS	SPMC240	SPMC241	SPMC481	SPMC482	SPMC1201	SPLC1200	SPLC1202
FEATURES							
Battery temperature sensor	Included						
Mid point battery voltage sensing	Included						
Front panel display and controls	22 x LED indicators with auto brightness for, charger status, battery capacity, alarms, AC status. Generator control button. On button. Silence Alarm button.						
Digital Inputs	4 of: Max 60 V DC (Active > +10 V, Inactive < +3 V)						
Inverter Topology	Isolated						
Protective Class	Class 1						
Operating ambient temperature	-20C to 60C						
Shunt Inputs	2 of: +/-75 mV, adjustable 25 A to 500 A						
Analogue Inputs	2 general purpose logged 0-60 V					n/a	
Relay Outputs	4 of: 60 V, 500 mA						
Digital outputs	3 of: 60 V, 5 mA						
Communication ports	USB and RS232 (optional Wireless and Ethernet)						
Memory retention of settings & data	Permanent						
SP LINK configuration and monitoring software	Standard, allows configuration of parameters and monitoring of parameters and SP PRO display remotely.						
Dimensions (mounted) W x H x D	375 x 690 x 220					540 x 870 x 293	540 x 870 x 293
Weight (with wall mount)	35 kg	39 kg	40 kg	42 kg	42 kg	113 kg	115 kg
Standards	IEC62019.1, IEC62019.2 ..and IEC 62040-1-1:2002 / AS 62040.1.1-2003 with CB certificate						
	AS/NZS 61000-6-3 2007				AS/NZS 61000-6-4 2007		
Grid Protection	AS/NZS 4777.2 2015						
Protection	IP43						

SUITABLE BATTERY TYPES AND VOLTAGE							
Decisive voltage class of battery port over current protection rating (Required to be installed external to inverter)	A				C		
		250A	250A	160A	250A	160A	250A
Lead acid batteries - Nominal Voltage	24 V	24 V	48 V	48 V	120 V	120 V	120 V
Lead Acid battery type	Suitable for all types of Lead acid battery technologies in both sealed and flooded cells. SP PRO charger settings must be configured to suit battery manufacturer's specifications						
Lithium battery - Nominal voltage and number of cells (assuming 3.2V per cell)	25.6 V 8 cells	25.6 V 8 cells	51.2 V 16 cells	51.2 V 16 cells	128 V 40 cells	128 V 40 cells	128 V 40 cells
Lithium battery type	Any Lithium battery technologies is suitable provided it is approved for the intended application. The Lithium battery bank must have its own Battery Management System that provides full protection and disconnection functions to ensure safe operation of the battery bank at all times and under all conditions. SP PRO charger settings must be configured to suit battery manufacturer's specifications.						
Aquious battery - Nominal voltage per stack and minimum number of stacks assuming 50AH rated capacity per stack	24V 5 stacks	24V 6 stacks	48V 5 stacks	48V 6 stacks	120V 3 stacks	120V 6 stacks	120V 8 stacks
Aquious battery type	The Aquious battery technologies is suitable provided it is approved for the intended application. The SP PRO charger settings must be configured to suit battery manufacturer's specifications Use the "Custom battery" setting within the SP PRO.						
Flow Battery - Nominal voltage	24V	24V	48V	48V	120V	120V	120V
Flow battery type	Any Flow battery technology is suitable provided it is approved for the intended application. SP PRO charger settings must be configured to suit battery manufacturer's specifications. Use the "Custom battery" setting within the SP PRO.						

All specification at 25C and Rated DC input voltage unless otherwise stated.
Specifications may change without notice.



Selectronic Australia Pty Ltd
© 2016

Suite 5, 20 Fletcher Rd
Chirnside Park VIC 3116
Australia
Ph +61 3 9727 6600
Fax +61 3 9727 6601

www.selectronic.com.au